

Zeitschrift: Bulletin de l'Association suisse des électriciens
Herausgeber: Association suisse des électriciens
Band: 40 (1949)
Heft: 17

Artikel: The Schmidt Optical System
Autor: Rinia, H.
DOI: <https://doi.org/10.5169/seals-1056393>

Nutzungsbedingungen

Die ETH-Bibliothek ist die Anbieterin der digitalisierten Zeitschriften. Sie besitzt keine Urheberrechte an den Zeitschriften und ist nicht verantwortlich für deren Inhalte. Die Rechte liegen in der Regel bei den Herausgebern beziehungsweise den externen Rechteinhabern. [Siehe Rechtliche Hinweise.](#)

Conditions d'utilisation

L'ETH Library est le fournisseur des revues numérisées. Elle ne détient aucun droit d'auteur sur les revues et n'est pas responsable de leur contenu. En règle générale, les droits sont détenus par les éditeurs ou les détenteurs de droits externes. [Voir Informations légales.](#)

Terms of use

The ETH Library is the provider of the digitised journals. It does not own any copyrights to the journals and is not responsible for their content. The rights usually lie with the publishers or the external rights holders. [See Legal notice.](#)

Download PDF: 18.01.2025

ETH-Bibliothek Zürich, E-Periodica, <https://www.e-periodica.ch>

d'analyse construits par Monsieur de France pour des nombres de lignes compris entre 700 et 1100.

Enfin, dans l'attente des relais hertziens et des relais par câble, attente qui sera dans certains cas très longue, nous souhaitons vivement que cette étude donne lieu à une exploitation industrielle et contribue à permettre rapidement des échanges internationaux de programmes. Ces échanges de

programmes augmenteraient dans une énorme proportion l'intérêt des émissions actuelles et aideraient certainement à la mutuelle compréhension des téléspectateurs de tous les pays.

Adresse de l'auteur:

Y. L. Delbord, Président du Comité Supérieur Technique de Télévision et Ingénieur en Chef de la Division «Télévision» du Centre National d'Etudes des Télécommunications, 15, rue Cognacq Jay, Paris 7^e.

The Schmidt Optical System

By H. Rinia, Eindhoven

535.313 : 621.397.5

Summary

In this article the principle of the Schmidt optical system is outlined. It is shown that the conventional form gives fifth order coma for low magnifications. Means are indicated to compensate this coma. The cause and magnitude of the lateral spherical aberration are discussed and a new method to compensate this aberration is shown.

1. Introduction

The Schmidt mirror system was invented for and in the beginning used only in astronomy. In recent years it has found a much wider field of application. It has made direct television projection economically, if not physically, possible. For this reason the study of its properties and some of its modifications, is of special importance for television.

Fig. 1 shows the types of the aberrations of the different orders. The coefficients of all these aberrations depend on the optical system considered

	0	O^3	O^5	5 Order
				Sfer. abb.
U		O^2U	O^4U	Coma
U^2	$O U^2$	$O^3 U^2$		
U^3		$O^2 U^3$		
U^4	$O U^4$			
U^5				
Distortion				
Field curv.				

Fig. 1
Aberrations of the 1, 3 and 5 order
 O = aperture; U = Field angle

and can be positive, zero or negative. In general these coefficients decrease with increasing order.

The first three of the fifth order aberrations containing O to a high power are of main importance in the Schmidt system, because of its very high aperture ratio.

The first is the fifth order spherical aberration proportional to O^5 . It is similar to the third order spherical aberration. The second is the fifth order coma, proportional to O^4U . It can be found from the departure from the sine condition. This deviation goes with O^4 .

But of considerable importance in the Schmidt system is the aberration proportional to O^3U^2 .

As it contains O^3 (as does the third order spherical aberration) but is dependent on U^2 (and not independent of it), it is called *lateral spherical aberration*. This aberration, however, can be different for rays in the plane of the drawing and in that perpendicular to it, so we can distinguish two aberrations of this kind.

The five remaining aberrations of the fifth order are of minor importance in the Schmidt system, and these will not be discussed here.

2. The Schmidt System

If we place in front of a sufficiently large spherical mirror AB (fig. 2) a diaphragm at the centre of curvature C , we see that for bundles of parallel

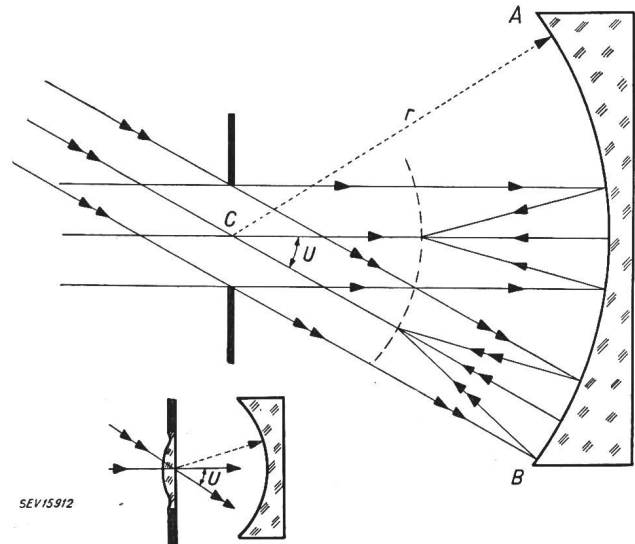

Fig. 2
Principle of the Schmidt system

rays from different directions the situation is the same. In fact the whole system is practically symmetrical around the centre of curvature. The parallel rays are focused approximately halfway between the centre of curvature and the mirror, on a sphere around this centre.

The mirror being spherical, there is of course a certain amount of spherical aberration, and the image surface is spherical, but these are the only aberrations present, because *all other aberrations* contain terms with some power of U and consequently must vary with the position on the image surface. We see, however, that the aberrations that are present do not depend on this position, and so all other aberrations must be zero. The mirror being achromatic, also chromatic aberrations are completely absent.

In order to compensate the spherical aberration and at the same time retain as far as possible the symmetry in order not to introduce new large aberrations, Schmidt placed in the diaphragm a refracting plate of such a form that it compensated the spherical aberration of all orders. However, for rays falling through the corrector plate at an angle U the situation is no longer the same as that for rays which fall perpendicularly on it. This lack of symmetry may cause new aberrations. As the optical power of the corrector plate serves only to compensate the spherical aberration, these new aberrations must be of a higher order. It is the effect of a correction on a correction!

Thus we may only expect aberrations of the fifth order and higher.

In the Schmidt system the curvature of the image plane will remain but this is overcome by giving the same curvature to the face of the cathode-ray tube or, in photography, by bending the film.

3. The Shape of the Corrector Plate

We shall now consider the Schmidt system in more detail and suppose that the object is lying at infinity. In fig. 3 TQ is a ray, parallel to the axis,

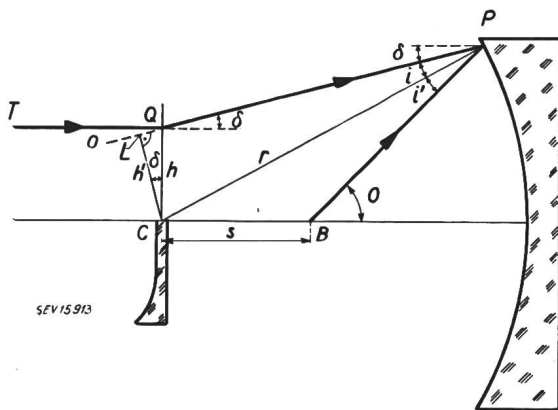

Fig. 3
Schmidt System with object at infinity

which has to be deviated by the corrector plate QC over an angle δ in order to focus it at B .

We draw the perpendicular $CL = h'$ on QP and note that CP , being a radius of the spherical mirror, is perpendicular to the tangent in P , thus $\sphericalangle i = \sphericalangle i'$ and $CP = r$.

In the triangle CPL we have

$$CL = CP \sin i \text{ or } h' = r \sin i = r \sin i'. \quad (1)$$

In the triangle CBP we have the condition

$$\frac{CP}{\sin O} = \frac{CB}{\sin i'}$$

and

$$r \sin i' = h' = h \cos \delta. \quad (2)$$

Thus

$$\sin O = \frac{h}{s} \cos \delta. \quad (3)$$

For most purposes $\cos \delta$ can be taken as equal to unity. From this we can calculate δ for any ray. We see that

$$\sphericalangle (2i + \delta) = \sphericalangle O \text{ or } \delta = O - 2i. \quad (4)$$

The combination of (1) and (2) gives

$$\sin i = \frac{h'}{r} = \frac{h \cos \delta}{r} = \frac{h}{r} \text{ if } \cos \delta \approx 1.$$

With (3) we can write (4) as

$$\delta = \arcsin \frac{h}{s} - 2 \arcsin \frac{h}{r}. \quad (5)$$

From (5) we can write δ as a power series of h .

It will be clear that δ depends on the angle between the two surfaces of the corrector plate. From the formula (5) for δ we can derive the expression of this angle as a function of h and by integration of that function we get the variation in thickness of the corrector plate.

In this way we find for the thickness d of the corrector plate.

$$d = d_0 + Ah^2 + Bh^4 + Ch^6 + \dots \quad (6)$$

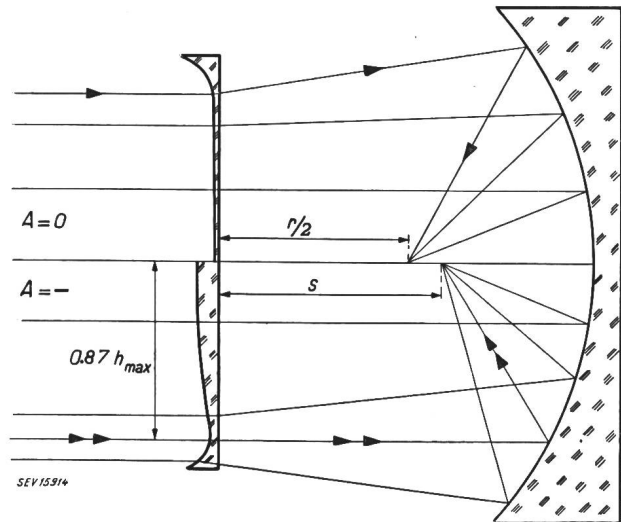

Fig. 4
Difference of the Schmidt corrector plate with and without spherical power A

It is obvious that because of the rotational symmetry of the system only the even orders of h are present.

The term Bh^4 corrects the third order spherical aberration, the term Ch^6 the fifth order spherical aberration, and so on. The coefficients of the higher order terms become very rapidly small.

If, in the expression (5) for δ , $s = \frac{r}{2}$ the coefficient

A becomes zero. If we make s larger than $\frac{r}{2}$ the coefficient A is negative and then the rays on an outer zone are unaffected and the corrector plate has a minimum thickness at this zone (fig. 4).

In practice the coefficients A and B are chosen in such a way that this minimum occurs at a zone of $0,87 h_{max}$. This form of the corrector plate has some advantages, mainly for reducing its already small chromatic aberration. As this residual chromatic aberration is very small, we shall not consider it here any further.

4. Coma of the Schmidt System

From the above calculation we see in equation (3) that the sine condition can be written as $\sin O = \frac{h \cos \delta}{s} = \frac{h}{s}$. Obviously the departure of the sine condition is $1 - \cos \delta$. When δ is small this varies by $\frac{1}{2} \delta^2$. If A is zero δ increases approximately by h^3 , so the departure from the sine condition then is proportional to h^6 . This gives rise to seventh order coma. Thus we see that both third and fifth order comae are zero. The seventh order coma is in our case completely negligible. If A is not zero the curve of the corrector plate contains a term with h^2 . The result is that, the maximum δ being reduced, the deviation from the sine condition is smaller. This is because the term Ah^2 introduces a slight amount of third order coma of opposite sign compensating partly the seventh order coma.

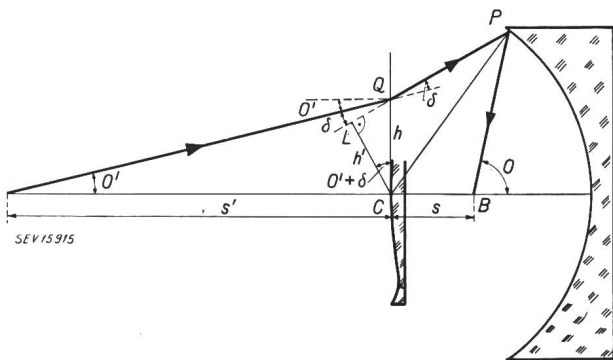

Fig. 5
Schmidt system with object at finite distance

The aberrations we have most to fear in a system with a wide aperture are spherical aberrations and coma, and we see that they are insignificant. But unfortunately this favourable situation changes somewhat when the object is at a finite distance, which is the normal situation with television projection. This is shown in fig. 5. It is analogous to fig. 3, with the important exception that now the angle between PQ and the corrector plate, which was formerly δ , has become $\delta + O'$.

From (3) we know that

$$\sin O = \frac{h'}{s}, \text{ which is } \frac{h \cos (O' + \delta)}{s}$$

and that

$$\sin O' = \frac{h \cos O'}{s'} \tag{7}$$

Thus the sine condition in this case is

$$\frac{\sin O}{\sin O'} = \frac{s' \cos (O' + \delta)}{s \cos O'} = \frac{s'}{s} (\cos \delta - \tan O' \cdot \sin \delta) \tag{8}$$

The departure from the sine condition has increased by an amount $\tan O' \cdot \sin \delta$, which is proportional to h^4 . A coma of the fifth order has now appeared and at low magnifications this can become objectionable.

To correct this we find that the corrector plate must be curved. We see (fig. 6) that if the corrector

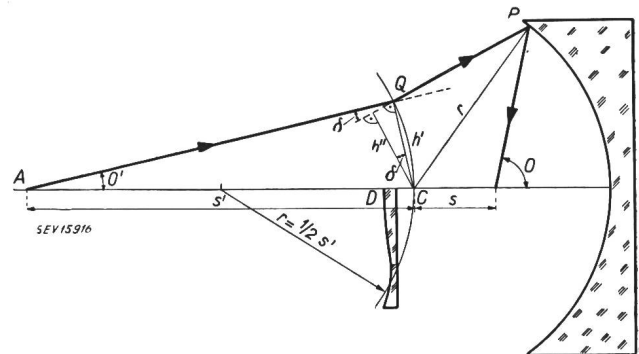

Fig. 6
Bending or shifting of the position of the corrector plate

plate is on a sphere with its centre halfway between A and C then, AC being a diameter, the angle AQC is always 90° and the angle between h' and h'' is again reduced to only δ .

Contrary to (7) we now get $\sin O' = \frac{h'}{s'}$ and in

combination with (3)

$$\frac{\sin O}{\sin O'} = \frac{s' h''}{s h'}, \text{ whilst } \tag{9}$$

$$h'' = h' \cos \delta.$$

The sine condition (9) is now

$$\frac{\sin O}{\sin O'} = \frac{s'}{s} \cos \delta.$$

The fifth order coma which was present in (8) has now disappeared.

It is clear that the average position of the corrector plate is now more forward, and, as a matter of fact, a flat corrector plate placed approximately at the position D reduces the coma sufficiently for all cases likely to arise in television. The shifting of the corrector plate causes third order coma which partly compensates the fifth order coma¹⁾.

We also find that the corrector plate must have increasingly higher power as the magnification becomes less. For a magnification m the coefficient B , for example, must be $\left(\frac{m+1}{m-1}\right)^2$ times that for infinite

¹⁾ In general it is possible, by shifting the corrector plate along the axis and/or bending it spherically or aspherically, to eliminate coma of any order.

object position. At the same time, however, the maximum angle O increases as the magnification becomes less. As the light gathered from the cathode-ray tube increases with $(\sin O)^2$, this is an advantage over a normal lens system, where O becomes smaller with decreasing magnification.

5. The Lateral Spherical Aberration

We shall now discuss the most harmful aberration of the Schmidt system and its origin.

The lateral spherical aberration is difficult to handle as are most higher order aberrations. In the case of the Schmidt system, however, it is possible to deal with this aberration in a simple way and to show its physical origin.

The power of a corrector plate is proportional to its variations in thickness as expressed by (6):

$$d = d_0 + Ah^2 + Bh^4 + Ch^6, \text{ and so on.}$$

Now, when a beam of light falls through a corrector plate (fig. 7a) under an angle U , we find that the light has to travel everywhere over a longer distance through the plate. The apparent thickness is increased and as a very rough, but for our purpose sufficient, approximation we shall assume that this has the same effect as an increase in thickness by a factor $\frac{1}{\cos U}$. (Figs. 7a and b.)

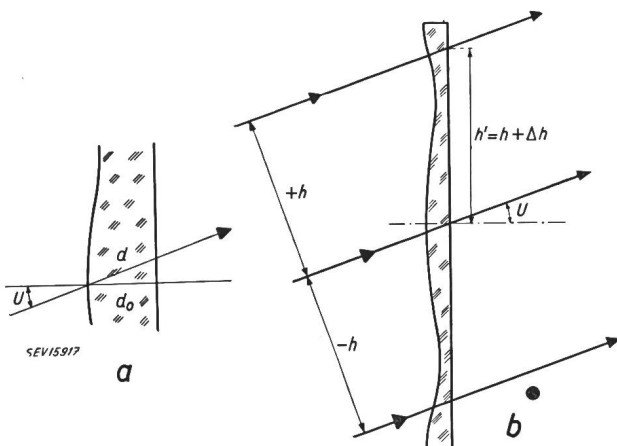

Fig. 7

Oblique rays through the corrector plate

For $d = \frac{d_0}{\cos U}$ the increase in d , which we call Δd , is

$$\Delta d = d_0 \left(\frac{1}{\cos U} - 1 \right) \approx \frac{1}{2} d_0 U^2.$$

If we put this into (6) this results in an additional thickness of the corrector plate:

$$\Delta d_{tang} = \frac{1}{2} U^2 [Ah^2 + Bh^4 + Ch^6 + \dots]. \quad (10)$$

But, in addition to this, the meridional rays (in the plane of the drawing) intersect the corrector plate at a point farther outward than they would do if they were falling perpendicular to it (fig. 7b). Thus they intersect the plate at

$$h' = h + \Delta h = \frac{h}{\cos U}.$$

$$\Delta h = h \frac{1}{2} U^2 \text{ in first approximation.}$$

We obtain the resulting increase in thickness by putting this into (6):

$$\begin{aligned} \Delta d &= A(h + \Delta h)^2 + B(h + \Delta h)^4 + C(h + \Delta h)^6 \dots \\ &\quad - [Ah^2 + Bh^4 + Ch^6 \dots] \\ &= 2Ah^2 \frac{\Delta h}{h} + 4Bh^4 \frac{\Delta h}{h} + \dots \\ &= \frac{1}{2} U^2 [2Ah^2 + 4Bh^4 + 6Ch^6 + \dots]. \end{aligned}$$

To this has to be added the effect of the general increase in thickness (10).

The total amount of additional apparent thickness is therefore

$$\Delta d_{mer} = \frac{1}{2} U^2 [3Ah^2 + 5Bh^4 + 7Ch^6 + \dots]. \quad (11)$$

Both terms with A represent the normal third order astigmatism caused by the spherical part of the corrector plate and have a ratio 1:3.

The second terms having a ratio 1:5 represent the tangential and meridional components of the lateral spherical aberration. The next terms represent similar aberrations of seventh and higher order and are smaller.

We see that for all rays the power of the plate has increased, but if we consider the most important term only (that is the fifth order term) it is five times more for meridional rays than for tangential ones.

This aberration, as we see it on the edge of the field of a Schmidt system, manifests itself as a faint figure-of-eight halo around a small spot in which still a high percentage of the light is concentrated. For this reason the effect is much less than one might expect from the maximum size of the aberration and the result is more a certain loss in contrast than in actual definition. For this reason the conventional Schmidt system satisfies in most cases the requirements for television projection systems. There are, however, a few modifications of the Schmidt system in which this aberration is absent.

Independently, *Bouwers* and *Maksutov* devised the system of fig. 8a. They used a thick glass lens with spherical surfaces of about the same radius, roughly concentric with the centre of curvature of the mirror. Such a lens has a very low power but considerable spherical aberration of opposite sign to that of a spherical mirror, just like a normal corrector plate. In this way they compensated the spherical aberration but this time the rotational symmetry is largely retained, and so no aberrations that depend on U can arise. Consequently the lateral spherical aberration is zero (Figs. 8a and b).

Unfortunately this very elegant solution has its disadvantages. It is not possible to compensate the

spherical aberration of all orders simultaneously, and so, when using a wide aperture, the definition is not always sufficient.

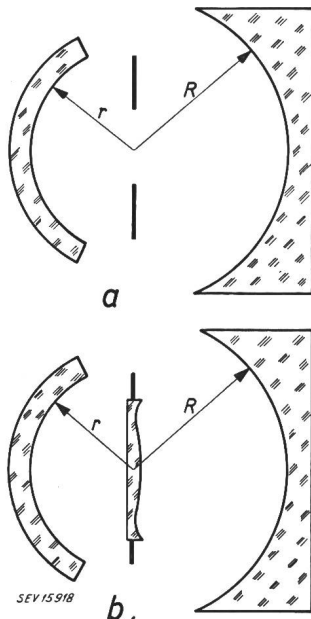

Fig. 8
Corrector systems

Top: Bouwers and Maksutov corrector system
Bottom: Hawkins and Linfoot corrector system

The chromatic aberrations of the lens are considerable, so that for many purposes it has to be achromatized by making it in two parts of different glasses. For large systems the practical difficulties of making such a deep meniscus lens are similar to those encountered in making a telescope objective lens of the same diameter. The first difficulty was overcome by *Hawkins* and *Linfoot* by placing at the centre of curvature a very weak corrector plate to compensate the residual aberrations (fig. 8b). This introduces some new aberrations, but because of the very low power needed these are very small.

We have found another way to compensate the lateral spherical aberration of all orders, using three aspherical corrector plates.

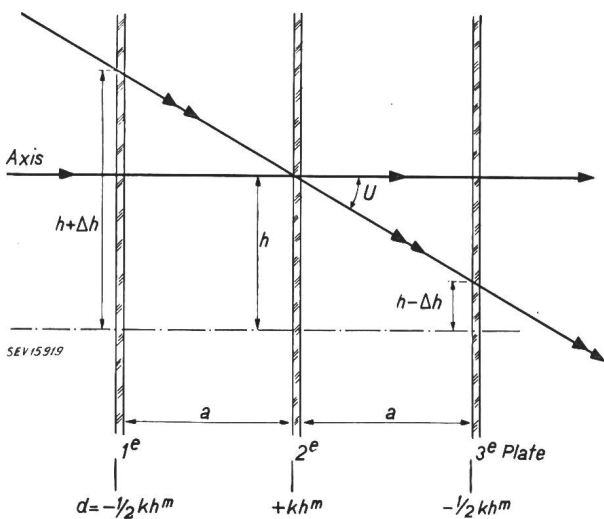

Fig. 9
Triple corrector plate

Suppose we have three centred aspherical plates, 1, 2 and 3 at distances a (fig. 9). The middle one has a thickness variation $d = kh^m$. The outer plates have a variation of opposite sign and one half of the amplitude of the middle one.

Thus the total power of the system is practically zero for rays falling parallel to the axis.

But a ray falling at an angle U , while intersecting plate 2 at approximately the original height h , intersects plate 1 at a point $h + \Delta h$, plate 3 at $h - \Delta h$ with $\Delta h = aU$.

The meridional increase in thickness of the system is for such an oblique ray:

$$\Delta d_{mer} = kh^m - \frac{1}{2} k (h + aU)^m - \frac{1}{2} k (h - aU)^m$$

$$\Delta d_{mer} = - \frac{1}{2} kh^{m-2} a^2 U^2 m (m-1). \quad (12)$$

To see what happens in the tangential plane we have drawn here a front view of the system (fig. 10).

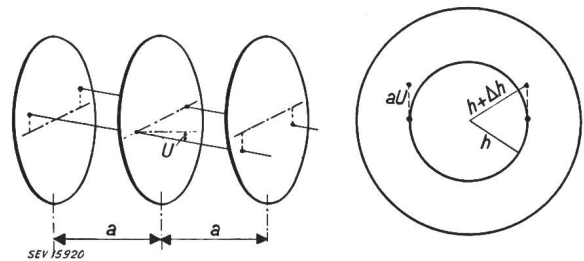

Fig. 10

Tangential plane through the triple corrector plate

We suppose that a ray lying in the tangential plane intersects the middle plate 2 at the same height h .

The first and second plates, however, are intersected higher and lower respectively, at a distance aU and on a zone further outwards to an amount of

$$\Delta h = \frac{a^2 U^2}{2h}$$

$$\Delta d_{tang} = kh^m - k (h + \Delta h)^m$$

$$= kh^m - k \left(h + \frac{a^2 U^2}{2h} \right)^m$$

$$= - \frac{1}{1} kh^{m-2} a^2 U^2 m. \quad (13)$$

For $m = 6$ in (12) and (13) the meridional, respectively tangential, result is:

$$\Delta d_{mer} = - \frac{1}{2} U^2 k_6 h^4 \cdot 6 \cdot a^2 \cdot 5,$$

$$\Delta d_{tang} = - \frac{1}{2} U^2 k_6 h^4 \cdot 6 \cdot a^2.$$

If we compare this result with the aberration of the same kind of the Schmidt corrector plate of eqs. (10) and (11),

$$\Delta d_{tang} = \frac{1}{2} U^2 h^4 B - \frac{1}{2} U^2 h^4 a^2 k_6 \cdot 6$$

and

$$\Delta d_{mer} = \frac{1}{2} U^2 5 h^4 B - \frac{1}{2} U^2 h^4 5 a^2 k_6 \cdot 6,$$

we see that if we make the coefficient k_6 such that

$$B = 6 a^2 k_6$$

this aberration is compensated. In the same way it is possible to compensate all aberrations of other orders containing U^2 caused by the term Ah^2 , Ch^6 , Dh^8 , etc. If we do this we find that in all cases we obtain with the compensating system the proper ratio of meridional to tangential components.

In addition to the effect expressed in formulae (12) and (13) there is the general equivalent increase in thickness of the whole system by an amount of $\frac{1}{2} U^2$. Therefore the right hand sides of eqs. (12)

and (13) have to be multiplied by $\left(1 + \frac{1}{2} U^2\right)$.

This means that at the edge of the field there is a slight over-compensation to be expected when the coefficients k are made as indicated. By making the corrector system slightly weaker, so that the lateral spherical aberration is compensated at the edges, the resulting under-correction on an intermediate zone is only $\frac{1}{4}$ of the over-compensation just mentioned.

In order to realize this compensation in practice we combine the original Schmidt plate with middle plate 2 by superimposing the curve of plate 2 on the original corrector plate and adding the other plates 1 and 3 at the required distance²⁾. If the distance is of the order of $\frac{1}{2} f$ the combined middle plate has about the same power and thickness variation as the original corrector plate.

²⁾ By combining the two systems the path of the rays is slightly different from that on which the calculation of the coefficients k_m is based. These coefficients have to be slightly corrected to compensate for this effect.

The power of the two outer plates varies proportionally to $\frac{1}{a^2}$.

It is not necessary that the outer plates should be placed at equal distances from the middle plate. If the distances are different the power of each outer plate must be proportional to $\frac{1}{a^2}$. In each case the middle plate must be varied according to the sum of their powers.

This method has the advantage that it can be realized with aspherical elements made in the conventional way and for large sizes.

Literature

- Schmidt, B.: Ein lichtstarkes komafreies Spiegelsystem. Zentral Z. Bd. 52(1931), S. 15...29.
Mitt⁷. Hamburg, Sternwarte Bergedorf, vol. 7(1932), p. 25 ... 27.
Schorr, R.: Das Schmidtsche Verfahren bei der Herstellung der Korrekionsplatten für komafreie Spiegel. Z. Instrumkde, vol. 56(1936), p. 336...338.
Maksutov, D. D.: J. Opt. Soc. Amer., vol. 34(1944), p. 270...284.
Bowers, A.: Achievements in optics, p. 25, 33.
Bowers, A.: Optik, vol. 3(1948), p. 320.
Lucy, F. A.: Exact and approximate computation of Schmidt cameras. J. Opt. Soc. Amer., vol. 30(1940), S. 251...254; vol. 31(1941), p. 358.
Herzberger, M., and H. O. Houdley: The calculation of aspherical correcting surfaces. J. Opt. Soc. Amer., vol. 36(1946), p. 334...340.
Glancy, A.: On the theory and computation of an aspherical surface. J. Opt. Soc. Amer., vol. 36(1946), p. 416...423.
Hawkins and Linfoot: An Improved Type of Schmidt Camera. Nature vol. 152(1946), p. 445...446. M. N. R. Astr. Soc., vol. 105(1945), p. 334.
Synge, J. L.: The Theory of the Schmidt Telescope. J. Opt. Soc. Amer., vol. 33(1943), p. 129...136.
Caratheodory, C.: Elementare Theorie des Spiegelteleskops von B. Schmidt. Hamburg. Mathem. Einzelschr⁷. 28, 1940.
French Patent 468.432, 23th May 1941.
French Patent 484.906, 11th Nov. 1942.
French Patent 527.921, 9th Jan. 1946.

Address of the Author:

H. Rinia, Ir., Director Philips Research Laboratories, Eindhoven, Netherlands.

Fernsehgrossprojektion nach dem Eidophorverfahren

Von H. Thiemann, Zürich

621.397.62 : 778.5

Die Erzeugung sehr grosser Lichtströme im Fernsehempfänger stellt auch heute noch eine sehr schwierige Aufgabe dar. Abgesehen von der Zwischenfilmmethode, welche keine eigentliche Lösung des Problems darstellt, stehen grundsätzlich zwei Verfahren zur Diskussion: Die naheliegendste und einfachste Lösung besteht bekanntlich darin, das auf dem Fluoreszenzschirm erzeugte Fernsehbild vermittelt einer lichtstarken Optik auf die Leinwand zu werfen. Das andere Verfahren hat zum Ziele, den Lichtstrom einer fremden Lichtquelle, zum Beispiel einer Bogenlampe entsprechend dem Fernsehsignal in seiner Grösse zu steuern.

Das Verfahren mit Fluoreszenzschirm ist heute in verschiedenen Ländern schon weit entwickelt worden. Es hat sich dabei gezeigt, dass eine

Lichtausbeute von zirka 5 Kerzen pro Watt erreicht werden konnte. Wenn wir berücksichtigen, dass der Fluoreszenzschirm weisses Licht erzeugen soll, so finden wir mit Hilfe des mechanischen Lichtäquivalentes, dass der energetische Wirkungsgrad eines solchen Fluoreszenzschirmes bereits den Wert von zirka 20% annimmt. Halten wir uns die komplizierten Vorgänge, welche bei der Abbremsung der Elektronen entstehen, vor Augen, so müssen wir diesen Wirkungsgrad als bereits sehr hoch ansprechen; es wird kaum damit zu rechnen sein, dass eine wesentliche Erhöhung desselben in nächster Zukunft zu erwarten ist. Da die elektrische Leistung des Kathodenstrahles beschränkt ist, so muss der Raumwinkel, unter welchem die Projektionsoptik Licht des Fluoreszenzschirmes erfassen kann, mög-