

**Zeitschrift:** Bulletin de l'Association suisse des électriciens  
**Herausgeber:** Association suisse des électriciens  
**Band:** 40 (1949)  
**Heft:** 17

**Artikel:** Television distribution over short wire lines  
**Autor:** Adorian, P.  
**DOI:** <https://doi.org/10.5169/seals-1056410>

### **Nutzungsbedingungen**

Die ETH-Bibliothek ist die Anbieterin der digitalisierten Zeitschriften. Sie besitzt keine Urheberrechte an den Zeitschriften und ist nicht verantwortlich für deren Inhalte. Die Rechte liegen in der Regel bei den Herausgebern beziehungsweise den externen Rechteinhabern. [Siehe Rechtliche Hinweise.](#)

### **Conditions d'utilisation**

L'ETH Library est le fournisseur des revues numérisées. Elle ne détient aucun droit d'auteur sur les revues et n'est pas responsable de leur contenu. En règle générale, les droits sont détenus par les éditeurs ou les détenteurs de droits externes. [Voir Informations légales.](#)

### **Terms of use**

The ETH Library is the provider of the digitised journals. It does not own any copyrights to the journals and is not responsible for their content. The rights usually lie with the publishers or the external rights holders. [See Legal notice.](#)

**Download PDF:** 18.01.2025

**ETH-Bibliothek Zürich, E-Periodica, <https://www.e-periodica.ch>**

- kurzwellen in der Schweiz. Sonderheft d. Schweiz. Arch. angew. Wiss. Techn. Solothurn 1938.
- [2] Gerber, W., u. F. Tank: Höhenstationen und Höhenverbindungen. Techn. Mitt". PTT. Bd. 25(1947), Nr. 5, S. 177...186.
- [3] Klein, W., u. J. Dufour: Rundspruchversuche mit frequenzmodulierten Ultrakurzwellen. Techn. Mitt". PTT. Bd. 26(1948), Nr. 1, S. 1...21, Nr. 2, S. 61...83.

- [4] Muri, A.: Sechzig Jahre Telephonie. Beil. Techn. Mitt". PTT. Bd. 19(1941), Nr. 4.
- [5] Keller, H.: Grundlagen für moderne Telephonnetze. Techn. Mitt". PTT. Bd. 25(1947), Nr. 6, S. 221...227.

**Adresse des Autors:**

Dr. W. Gerber, Generaldirektion der PTT, Speichergasse 6, Bern, Schweiz.

## Television Distribution over Short Wire Lines

By P. Adorian, London

621.397.24

### Introduction

In closely populated areas, and in particular in blocks of flats, the siting of television aerials presents many difficulties to individual householders.

It is usually possible to locate a good television aerial system at the top of a block of flats giving reasonably good reception. The remaining problem, therefore, is to distribute the signal received by this aerial to the tenants in the block of flats concerned.

The same problem applies to groups of houses sharing a communal television aerial. The advantages of the latter case may not be fully appreciated, but it has been established in practice that there is a considerable variation in signal to noise ratio at sites quite close to one another, depending on the relative position of the receiving aerial, transmitting aerial and sources of interference. Thus, while on one side of a road considerable interference may be caused by passing traffic, on the other side of the same road, by the use of a reflector on the receiving aerial, this interference can be reduced very considerably. It is obvious that it is a great advantage to bring up the quality of reception on both sides of the road to the same level.

Ultimately, one can visualise large groups of such local wire television distribution systems interconnected by a main distribution system.

The present paper is limited to the problem of local distribution, but reference is made to the use of the wire distribution system for the simultaneous distribution of radio broadcast programmes.

### Choice of System

There are several methods by which television programmes can be distributed.

The group of companies with which the author is associated is concerned with the distribution of sound broadcast programmes at audio frequencies to hundreds of thousands of homes in Great Britain and overseas and, therefore, is interested in the distribution of television. Accordingly, some 12 years ago, soon after the BBC television transmissions started, experimental investigations were started on the most suitable method of distribution of television programmes.

The main methods by which such distribution can be achieved are as follows:

#### *Video Frequency Distribution*

The system of distribution at video frequencies, say 0 to 5 Mc./s might at first sight seem the most advantageous owing to the simplicity of the receiving sets. It also has the advantage that for very short distances, the various high tensions and other power supplies could also be transmitted on cables as well as the audio frequency sound programmes so that the viewer would have an extension loudspeaker for sound reproduction and a cathode ray tube display unit for picture reproduction with little additional equipment and no direct local connection to the electric mains supply.

After practical examination of this system, the conclusion was reached that the saving made in cost of receiving equipment would be counterbalanced by the cost of special cables and distribution equipment required. Further, it was thought, right from the beginning, that eventually, due to mass production, the price of television sets would come down to such a low figure that the technically simpler sets such as envisaged by this system, but made in smaller quantities, could not be made at much lower prices.

A further technical difficulty that must be taken into account in this system is that at video frequencies careful correction of lines is necessary if serious distortion is to be avoided. It must be remembered that at video frequencies the attenuation along wire lines of the low and high frequencies is very different and such attenuation will vary considerably along the line. In addition, correction must be made for phase distortion. Thus, such systems are very critical as regards variation in load, which would entail expensive engineering operation.

#### *Intermediate Frequency Distribution*

The system of distribution at an intermediate frequency carrier on which the modulation could be superimposed has also been considered. A carrier of the order of 10 Mc./s was considered with modulation of up to + 5 Mc./s.

This system has the advantage of simplifying the television receivers by elimination of the radio frequency part of the equipment. However, it introduces more complicated sending end equipment and on balance could only be justified with very large systems.

#### *Direct Carrier Distribution*

The third system which was considered consists of receiving, amplifying and distributing over wire lines the complete carrier and sidebands of the transmitted programmes. In this case the programmes distributed are the BBC London television programmes, the technical standards of which have been published elsewhere. It might be mentioned here, however, that for correct transmission of these signals, a frequency band from 41 to 49 Mc./s should be transmitted.

The advantages of this system are numerous. Firstly, subscribers connected to the system can utilize any television receiver suitable for the London transmission. Next, the distribution equipment is extremely simple and, what is considered most important, the system is not particularly critical as regards load variation and, once a television supply feeder is constructed and laid out to the plan described below, there is no further engineering involved except normal maintenance.

A disadvantage of this system may be that as a relatively high carrier frequency is used, a more expensive cable may have to be employed than for a system distributing at lower frequencies but in practice this difference in cost is almost negligible in relation to the total cost of the installed system.

It has been found in practice that this type of distribution system can be operated with line lengths up to 500 metres.

A further advantage of this system is that as the frequencies below 40 Mc./s are not used for main television distribution, the same concentric cable can be used for providing aerial inputs to broadcast receivers and possibly at a later date, when high television subscriber densities are obtained, a second television programme, if available, could be simultaneously transmitted on the system in accordance with the intermediate system referred to above.

#### **Description of Direct Carrier Distribution**

In view of the foregoing considerations, this system was adopted and at the time of preparing this paper 57 systems have been installed making television service available to 6400 households of which approximately 600 are subscribing to the system.

In view of the interest already shown, it is expected that this number will increase considerably in future and work is in hand for the installation of similar systems for several other groups.

The system used is shown schematically in Fig. 1.

A conventional vertical di-pole with reflector is used which is connected to a broad band amplifier and from this, connection is made to up to three concentric cables through a

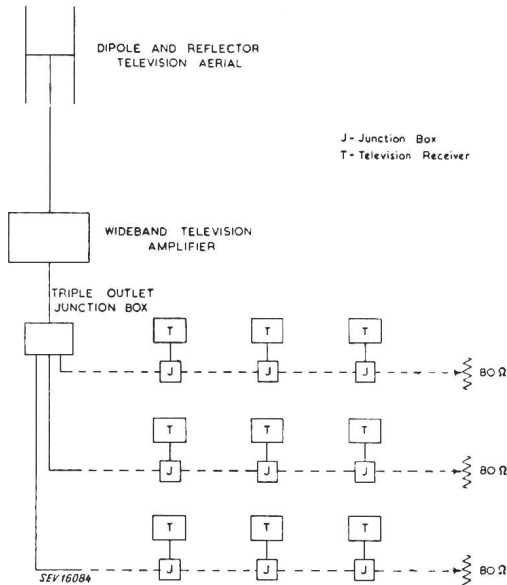

Fig. 1  
Direct Carrier Distribution System

further away from the sending end introduce a loss of 20 db between line and receiver.

The circuit of the television amplifier is shown in Fig. 2.

This wide band amplifier gives approximately uniform gain of 55 db from 42 to 48 Mc./s. The response falls off symmetrically at each end and the response is about 6 db down at 41.5 Mc./s and 48.5 Mc./s respectively.

The amplifier gives an output voltage of sufficiently high level that when followed by a three-way matching pad connected to three 80 Ω lines, an input voltage of 0.75 V is available to each line. All the four amplifying valves are of the same type and a valve rectifier is used in the built-in alternating current mains power unit.

A concentric semi-air spaced polythene insulated cable with the following dimensions and characteristics is used for distribution:

Overall diameter:	0.685 cm
Inner conductor diameter:	0.091 cm
Outer conductor diameter:	0.533 cm
Loss per metre at 45 Mc./s:	0.06 db
Loss per metre at 1 Mc./s:	0.009 db
Characteristic impedance of cable:	75—80 Ω

The system has been so designed that the input voltage to receivers at different positions along the line is not less than 0.75 mV and not more than 7.5 mV.

The system is designed to supply under these conditions up to about 30 television receivers on each line spread over a length not longer than 480 metres.

Fig. 3 shows the performance of such a feeder, 480 metres in length with 32 television receivers connected, distributed uniformly along the feeder.

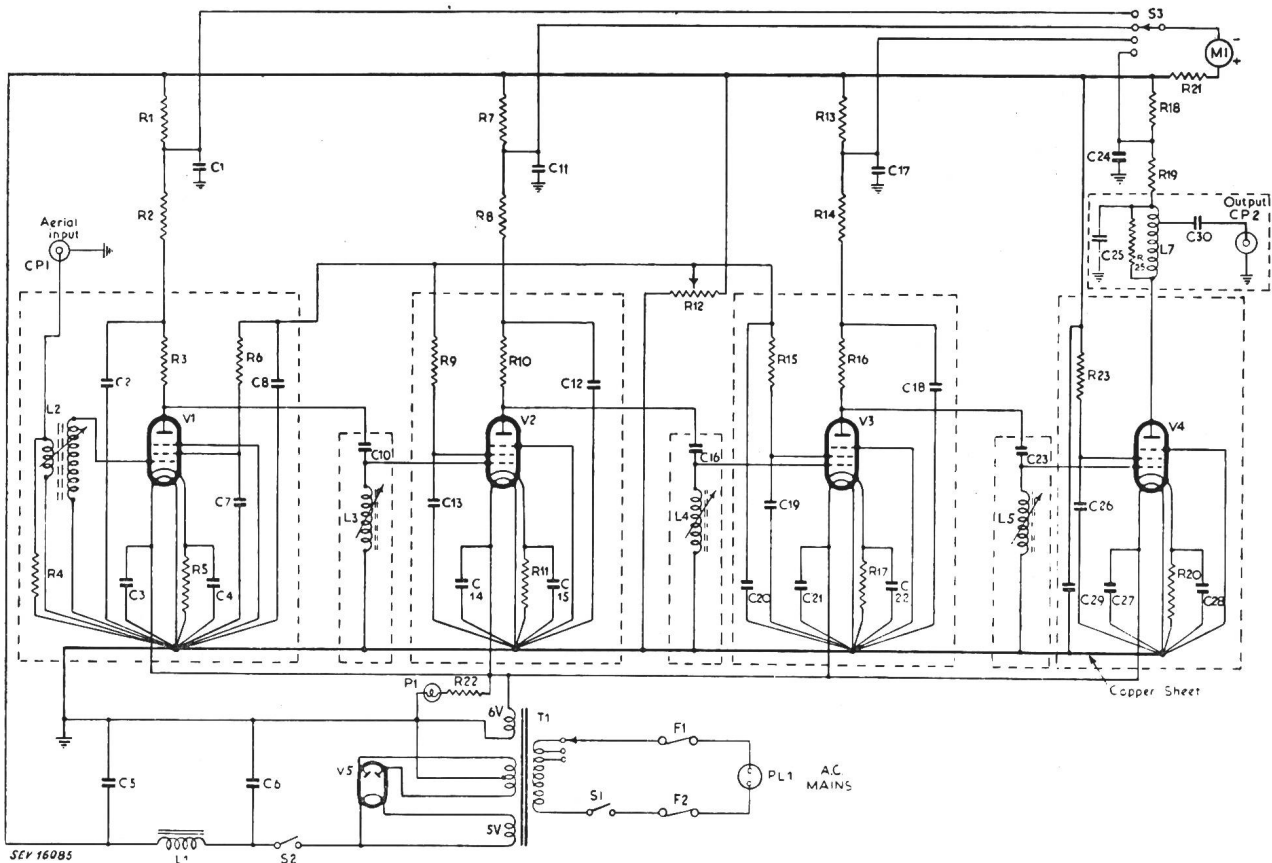

Fig. 2  
Wideband Television Amplifier

matching arrangement. In the diagram the concentric distribution cables are shown in dotted lines.

It should be noted that, as explained later, the junction boxes include a loss pad which, near the sending end, introduces a 40 db loss between line and receiver, while the matching pads

The top graph in this diagram shows the attenuation along such a feeder in a completely unloaded condition but the end of the line is terminated with an 80 Ω resistance, which is always used. The middle graph shows the actual line voltage due to the attenuation caused by the connection of the television

receivers, while the bottom graph shows the actual voltages as applied to the inputs of the television receivers along the line. It should be noted that the first 16 receivers are connected through 40 db pads while the second 16 receivers are con-

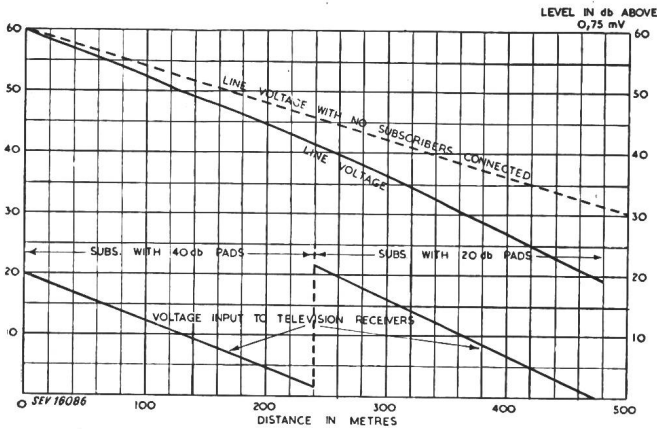

Fig. 3  
Characteristics of Television Line Distribution  
(one subscriber per 15 metres)

nected through 20 db pads. (As the receiver input impedances are about 75—80 Ω each, in the case of 40 db pads a 7500 Ω series resistance is used while in the case of 20 db pads a 750 Ω series resistance is used at the appropriate junction boxes.)

can feed one line. Thus, 15 lines can be supplied. The schematic, Fig. 4, shows the general arrangement. Fig. 5 shows the circuit diagram of the output amplifier incorporating five one-stage amplifiers.

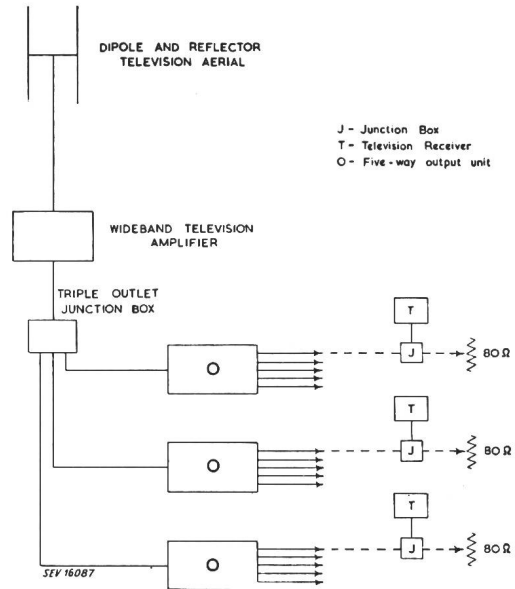

Fig. 4  
Direct Carrier Distribution System with increased scope

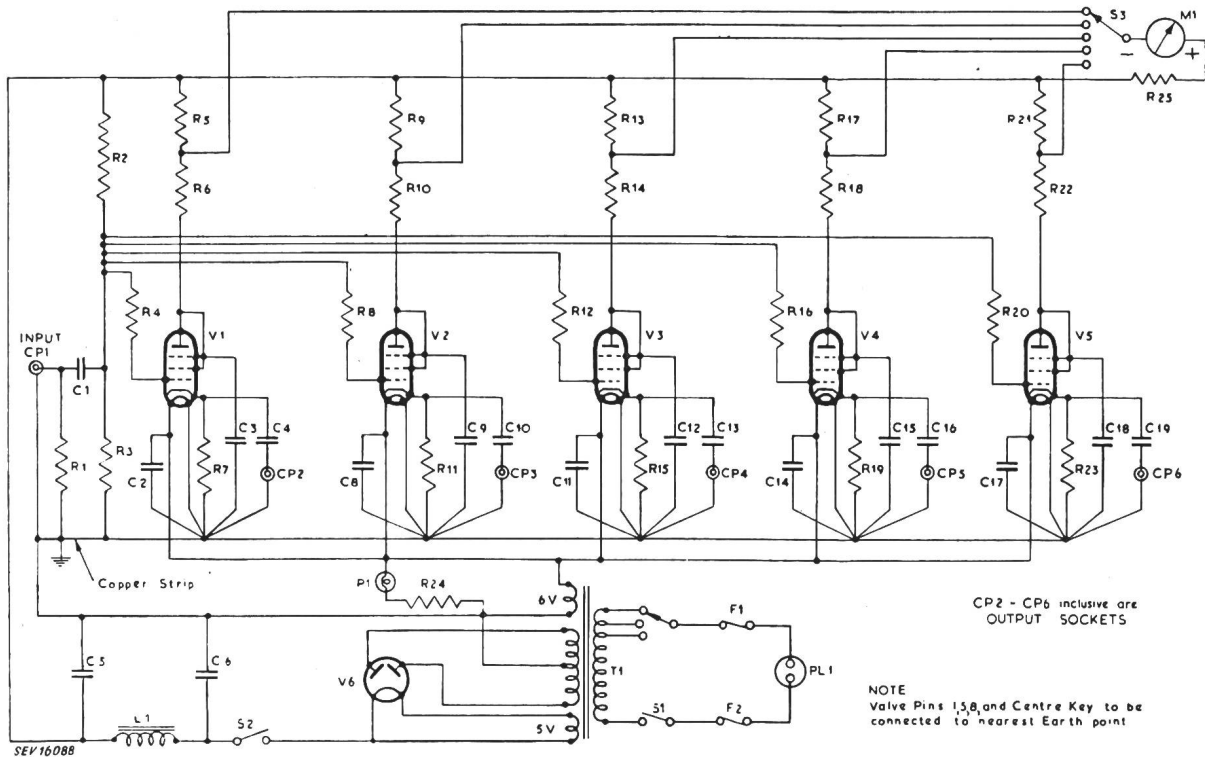

Fig. 5  
Television Output Unit

**Increasing the Scope of the System**

While the system described above is able to supply over 90 television sets on three lines, a further extension of the system has been developed by means of which it is possible to feed up to 15 lines and a total of about 450 subscribers.

In this arrangement the output of the wide band television amplifier is connected to the inputs of up to three output amplifiers. Five similar one-stage amplifiers are incorporated in each output amplifier and each of these one-stage amplifiers

A further extension of the system is possible by extending the length of the feeders by the introduction of repeater amplifiers, but up to the time of writing this paper, this has not yet been necessary in practice.

**Television Distribution Combined with Radio Broadcast Distribution**

The system has been further developed for use as a combined television and broadcast aerial system, in its present

form for the distribution of medium and long wave broadcast inputs and the television distribution described above. The general sending-end arrangement used is shown in Fig. 6 and is self-explanatory.

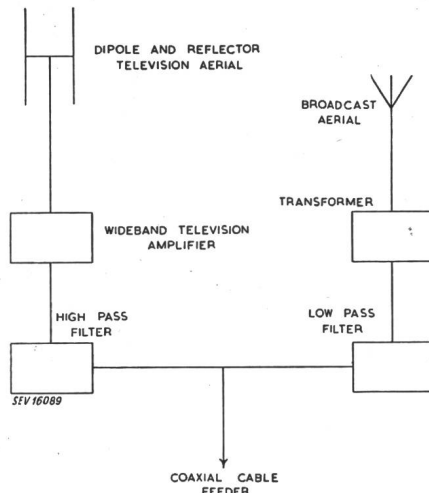

Fig. 6  
Combined Television and Broadcast Aerial System  
General sending-end arrangement

Where such arrangements are in use, it is usual to connect the aerial terminal of the subscriber's broadcast receiver to the concentric cable through a 750 Ω resistance and connect a small condenser which presents high impedance to the medium and long wave broadcast signals, in series with the subscriber's television set aerial terminal.

It will be noted that no wide band amplifier is shown in conjunction with the broadcast aerial as this is not necessary at sites where strong broadcast signals are available but such an amplifier could be included between the aerial and the low pass filter if necessary.

**Conclusions**

A system has been developed and is in commercial operation in London giving subscribers the equivalent of a television aerial, and also combined with a medium and long wave broadcast aerial. This system is particularly suitable for closely populated areas where reception conditions may be difficult and even the siting of aerials may be difficult or impossible. The system has been developed to cater for the highest density of population that can be expected. The system can be further extended by interconnection with longer lines and direct connection to the television studios so as to deliver direct to subscribers television programmes from the studios.

**Acknowledgements**

The author wishes to record with thanks permission received from Central Rediffusion Services Limited to disclose this information, which is the result of development by that Company. The author also wishes to thank Messrs. H. J. Barton Chapple, B. Sc., M.I.E.E., M. Brit. I.R.E., of the Engineering Division of Central Rediffusion Services Ltd., and R. I. Kinross, A.M.I.E.E., Chief Engineer of London Rediffusion Service Ltd., who have been mainly responsible for this development and who have assisted in the preparation of this paper.

**Address of the Author:**

P. Adorian, M.I.E.E., M. Brit. I.R.E., Chairman, Central Rediffusion Services, Ltd., Carlton House, Lower Regent Street, London, S. W. 1.

**Premiers résultats d'essais de Stratovision aux Etats-Unis d'Amérique**

Par Ed. J. Aubort, Zurich

621.397.5 : 629.135

**I. De l'idée aux premiers essais de stratovision**

C'est le 23 juin 1948, peu après l'annonce de la Conférence Internationale à Zurich, qu'ont eu lieu les premières démonstrations publiques des possibilités de la stratovision. L'auteur a eu le privilège de se trouver à Pittsburgh ce jour-là où l'avait attiré, non pas la télévision, mais une invitation à visiter ce centre de l'électrotechnique américaine et en particulier les laboratoires et les fabriques de la Westinghouse Electric Corporation.

Comme la Presse de ce jour exposait au public de Pittsburgh les origines et les résultats des premiers essais de stratovision, nous avons rassemblé les résultats pour vous en informer.

Un jeune ingénieur, Edward Nobles, entraît peu après ses études en 1939 à l'usine de Baltimore où la Westinghouse Electric développe et fabrique son matériel d'électronique. Spécialiste en radar et télévision, Nobles eut, fin 1944, l'intuition des possibilités que donnerait l'avion pour porter très haut dans le ciel l'antenne radiante de télévision. Il obtint de ses chefs l'appui nécessaire pour réaliser son idée à Baltimore même.

C'est la réalisation de ce projet que nous allons exposer, car il est probable que l'idée en elle-même n'était pas neuve et que d'autres ont voulu utiliser des ballons pour retransmettre des ondes radioélectriques. On s'est même servi d'avions pour faire les relais entre une place de sport éloignée, par exemple, et l'émetteur de télévision situé quelque part dans une grande ville.

La fig. 1 montre le principe de la stratovision. Reçu du sol, le programme est retransmis par un ou plusieurs avions sur une surface au moins 20 fois supérieure à celles que chaque émetteur pourrait normalement desservir, permettant à la population de participer à la vie théâtrale, non seulement dans quelques grandes villes, mais aussi dans les villages et fermes reculées des montagnes. L'avion lui-même peut servir de relais et permettre à d'autres avions la radiodiffusion d'images et de

sons sur tous les territoires où la densité de population est suffisante pour justifier ce service. Ces avions se relaient pour assurer un service continu, même en cas de panne, puis rentrent au prochain point d'attache en survolant les zones orageuses.

**II. L'avion des premiers essais**

En transportant l'antenne d'émission et l'émetteur sur un avion qui vole dans un petit cercle à une grande altitude et hors de notre vue, mais sans qu'il y ait d'obstacles entre

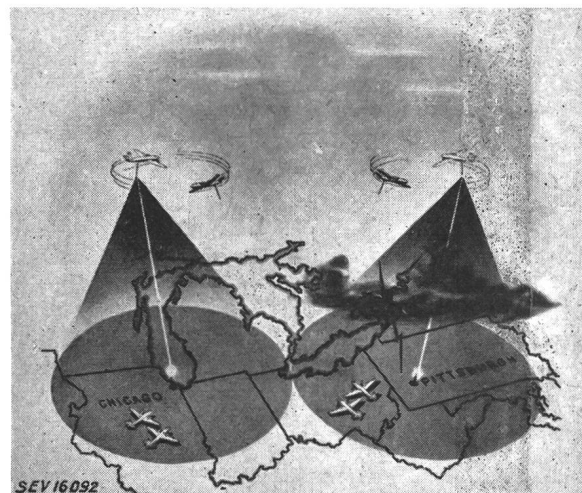

Fig. 1  
Retransmission des programmes

Volant bien au-dessus des nuages orageux, un ou plusieurs avions, qui reçoivent du sol les programmes de télévision, les retransmettent