

Zeitschrift: IABSE congress report = Rapport du congrès AIPC = IVBH
Kongressbericht

Band: 11 (1980)

Artikel: Steel reticulated plates in industrial buildings

Autor: Mezzina, Mauro / Prete, Giuseppe / Tosto, Antonio

DOI: <https://doi.org/10.5169/seals-11276>

Nutzungsbedingungen

Die ETH-Bibliothek ist die Anbieterin der digitalisierten Zeitschriften. Sie besitzt keine Urheberrechte an den Zeitschriften und ist nicht verantwortlich für deren Inhalte. Die Rechte liegen in der Regel bei den Herausgebern beziehungsweise den externen Rechteinhabern. [Siehe Rechtliche Hinweise.](#)

Conditions d'utilisation

L'ETH Library est le fournisseur des revues numérisées. Elle ne détient aucun droit d'auteur sur les revues et n'est pas responsable de leur contenu. En règle générale, les droits sont détenus par les éditeurs ou les détenteurs de droits externes. [Voir Informations légales.](#)

Terms of use

The ETH Library is the provider of the digitised journals. It does not own any copyrights to the journals and is not responsible for their content. The rights usually lie with the publishers or the external rights holders. [See Legal notice.](#)

Download PDF: 19.03.2025

ETH-Bibliothek Zürich, E-Periodica, <https://www.e-periodica.ch>

**IV****Steel Reticulated Plates in Industrial Buildings**

Plaques à treillis en acier pour la construction industrielle

Räumliche Fachwerke aus Stahlplatten im Industriebau

MAURO MEZZINA

Ass. Prof.
Universita di Bari
Bari, Italy

GIUSEPPE PRETE

Prof.
Universita di Bari
Bari, Italy

ANTONIO TOSTO

Ass. Prof.
Universita di Bari
Bari, Italy

SUMMARY

This paper concerns the application of special structures such as steel reticulated plates in industrial buildings. Their typological aspects and technical characteristics are examined. For the solution of technological and erectional problems, an original constructional system is proposed, together with some significant experiments.

RESUME

On examine les applications des plaques réticulaires métalliques dans les bâtiments industriels et leurs aspects typologiques et techniques. On propose ainsi un système de construction original pour la solution de problèmes technologiques et de montage, avec la description de quelques essais significatifs qui ont été réalisés.

ZUSAMMENFASSUNG

Der Artikel behandelt die Anwendung spezieller Strukturen, z.B. räumliche Fachwerke aus Stahlplatten im Industriebau. Ihre typologischen Aspekte und die technischen Eigenschaften werden untersucht. Es wird ein neues Konstruktionssystem zur Lösung der technologischen Probleme sowie der Probleme bei der Montage dargestellt – zusammen mit einigen der durchgeführten Untersuchungen.



1. TYPOLOGY AND USE

The most important applications of metallic space structures in civil and industrial buildings are reserved to flat or slightly curved reticulated plates. They are double (or triple) layered grids made up of two (or three) parallel and

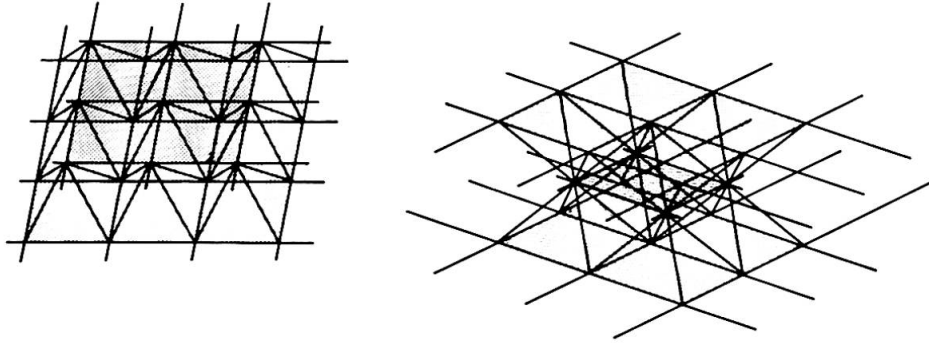

fig. 1

modular networks interconnected by vertical and diagonal web members and loaded normally to their plane (fig. 1).

The base networks, multi-directionally framed in their plane, can be perfectly overlapped or joggled, geometrically identical or different. The most frequent network schemes are shown in fig. 2. In particular we define the bi-directional grid as rectangular if the members cross at 90° and are side parallel; otherwise diagonal if they are slanted on their support line. Sometimes networks, lightened by taking away suitable members and nodes, are used. The most significant recent development of this typology is represented by the bi-directional crossed grid (fig. 3): it is obtained by diagonalizing one of the layers (top or bottom) and leaving the other as a rectangular one (diagonal on square or square on diagonal grid).

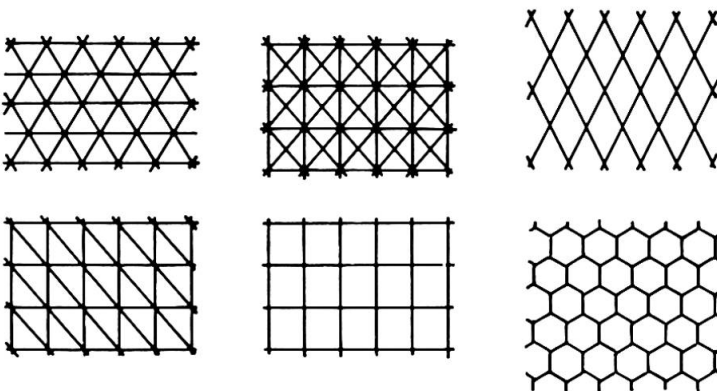

fig. 2

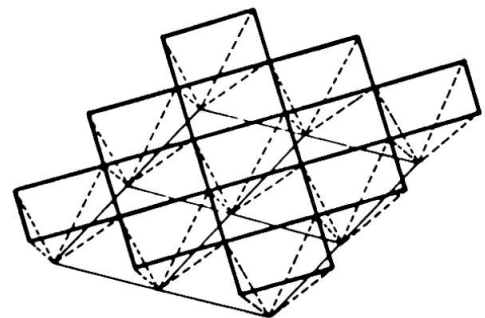

fig. 3

The reticulated plates are characterized by the favourable effect of the force distribution; these are in fact almost exclusively axial since the loads are

normally applied on the nodes. Each element of these structures performs, in optimal conditions, a lot of static and constructional functions: the members are, at the same time, principal beams, secondary beams and bracings.

Presently their major use is reserved for the covering of special large span constructions: theatres, exhibition centres, sport pavillions, churches, hangars, etc; but also for flooring of normal multistoried civil and industrial buildings with small spans. In this case their use is often joined with prefabricated collaborating r.c. panels.

Their depth varies between $1/20$ and $1/30$ of the span, changing with the loading, the geometric scheme and the node distance. The open space between the two layers enables horizontal technical services contained within the volume of the structure (1).

Regarding their analysis, we note that the computer program use has presently eliminated any difficulty, while the handle calculation is now usually reserved for the pre-dimensioning, in which they can be analyzed as continua, applying the plate or shell analogies (2).

2. CONSTRUCTIONAL PROBLEM: THE PERMIT SYSTEM

The great interest in reticulated plates is reflected in the large number of commercial construction systems recently developed throughout the world. Among the well-established and already well-known systems we mention the Mero, Oktaplatte, Unistrut, Unibat, Nodus, etc. These systems are different both for the construction method and for the node assembling. The "node" is the key element of these structures. It must be sufficiently resistant for transmitting the member forces, undeformable under static and dynamic loadings and easy to construct and erect. Several of the systems presently used, even if optimal from a static and aesthetic point of view, nevertheless present some economic disadvantages. These are due to the complexity of the assembling nodes, requiring expensive special pieces and made with sophisticated technological processes, or to the necessity of field weldings.

We shall explain here our solution of the problem already applied in some important buildings, after suitable experimental tests (3).

The system, named PERMIT, uses the same elements and procedures of the traditional carpentry buildings with which we believe it competitive from an economic point of view. It is based on the shop construction of two standard structural components (fig. 4): the diagonal member, typically made up by a tubular section, and the chord member (top or bottom), preferably made up by tubular section, but also by different sections. Both elements have a suitable equipment welded at their ends ("niches" or "small-plates"). The structural assembling follows then immediately (fig. 5): the grid generic node is obtained by the juxtaposition of four diagonal and chord members. The connection is ensured, without any eccentricity, by means of only four H.S. friction bolts.

The proposed system, according to modular coordination criteria of structural components with selected unitary dimensions, serves for the construction of reticulated plates with rectangular bi-directional and diagonal schemes (with top



and bottom joggled networks) or with derived lightened schemes; with some simple modifications this system can be applied also to the crossed grid of fig. 3.

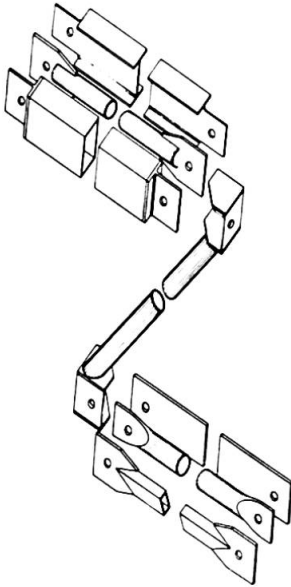

fig. 4

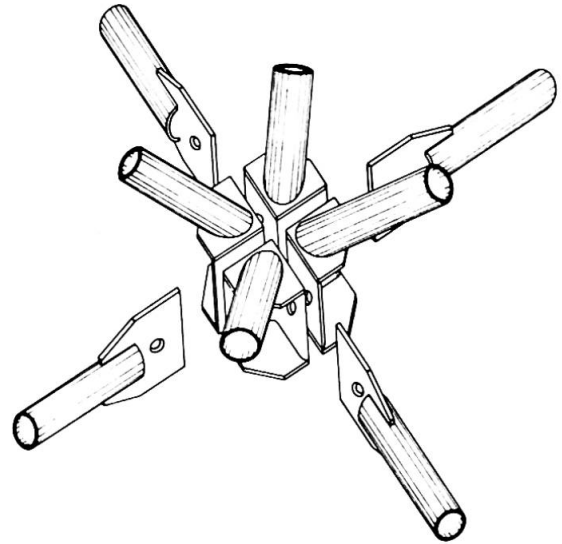

fig. 5

Its principal advantages are as follows:

- The node is obtained without the aid of any special loose part (as plate, ball, diaphragm, etc.) to hold the junction; its mechanical function is exclusively obtained through its elements: "bolts", "niches" and (optional) "small-plates".
- All the structural components of this system can be completely prefabricated in a workshop, including all its welding operations.
- For the member realization, either the use of tubular or open section profiles is possible.
- The final assembling of the structure is carried out in the working-place with only four friction bolts per node, in which eight members converge.
- It is possible to partially neutralize the secondary moments in the chord members, due to loads directly applied on them, marking-out the structural elements with a pre-fixed and suitable eccentricity between the geometric and the bolt axes.
- Due to its special simplicity, the node can be easily calculated because of a mathematical schematization, which permits the static dimensioning of all its components (4).

3. LABORATORY AND DESIGN EXPERIENCES

Suitable laboratory experiences have been performed both on node models (fig. 6)

and on double layered grid prototypes (fig. 7), purposely realized, for verifying the static and functional validity of the PREMIT system. The experimental

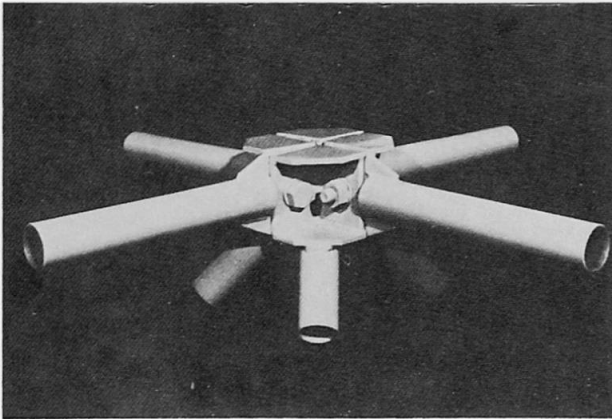

fig. 6

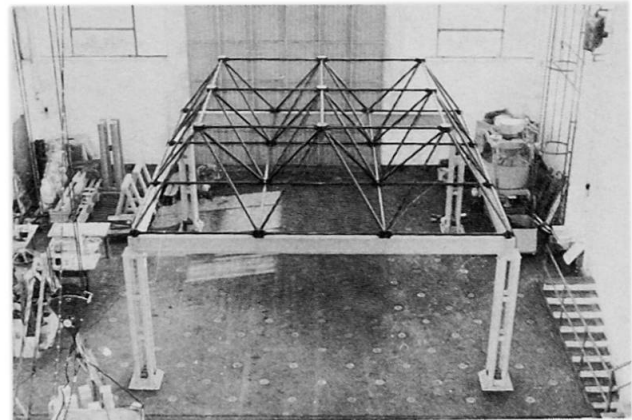

fig. 7

		COMPARISON VALUES : THEORET. EXPERIM. VARIATION %			
MODEL NODE TESTS	UNIAXIAL TENSION	SLIP LOAD	71196 N	88260 N	+24
		SLIP SAFETY FACTOR	1.25	1.55	+24
		COEFFICIENT OF FRICTION	0.30	0.372	+24
MODEL NODE TESTS	BIAXIAL TENSION	SLIP LOAD	54770 N	68647 N	+25
		SLIP SAFETY FACTOR	1.25	1.56	+25
		COEFFICIENT OF FRICTION	0.30	0.407	+36
PROTOTYPE GRID TESTS	MECHANISM INSTABILITY LIMIT STATE	CRITICAL MULTIPLIER	3.23	4.00	+24
		BUCKLING SAFETY FACTOR	1.50	1.85	+23
		MAX. DEFLECTION	5.46 mm	6.65 mm	-22
PROTOTYPE GRID TESTS	MECHANISM LIMIT STATE	ULTIMATE MULTIPLIER	7.33	7.50	+2.3
		COLLAPSE SAFETY FACTOR	1.51	1.55	+2.6
		MAX. DEFLECTION	9.66 mm	9.80 mm	-1.4

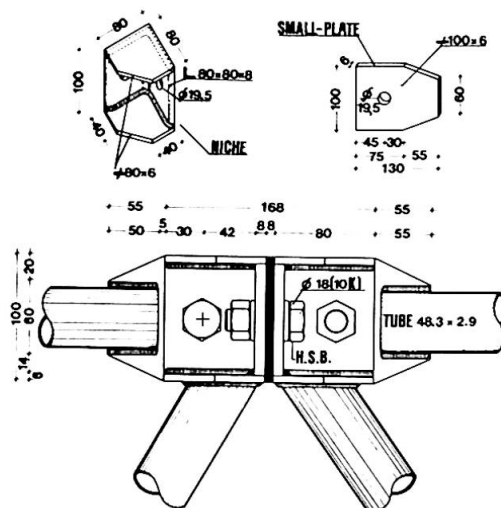

fig. 8

tests have always been carried out up to the collapse and the results, found very interesting, have been reported in (3). Referring to the node in fig. 8,



we have here enclosed a table in which it is possible to note the slight variations between the theoretical and experimental values.

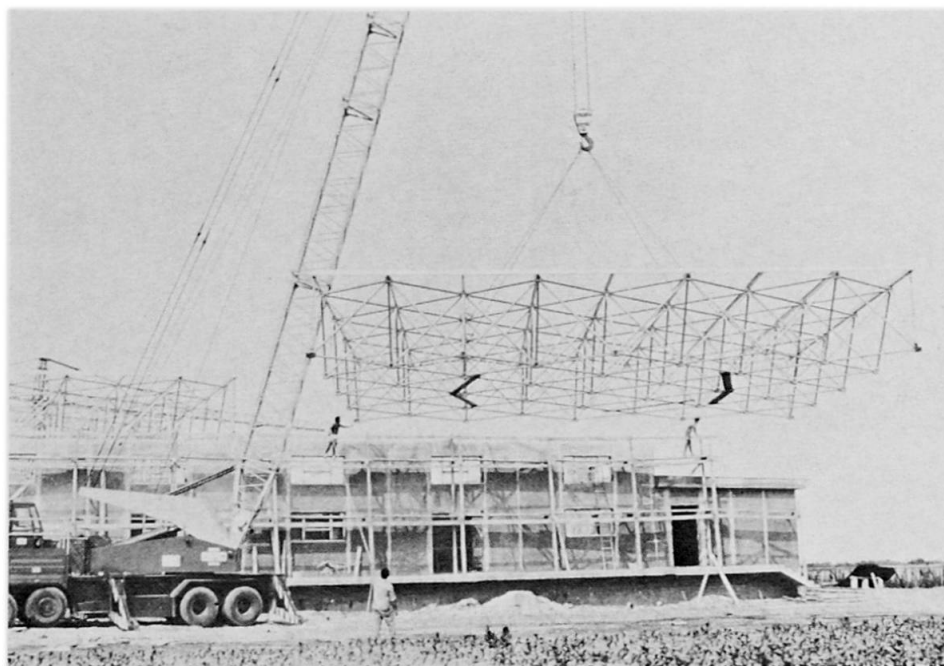

fig. 9

After these conforing experiences we have applied our PERMIT system in some industrial building coverings (5), using the "lift-slab" method for the erection, with excellent economic results (fig. 9).

REFERENCES

1. A. PADUART: Structures spatiales discontinues. C.B.L.I.A., Bruxelles, 1973.
2. G. PRETE: Analisi al continuo di grigliati spaziali multipli. Atti dell'Istituto di Scienza delle Costruzioni dell'Università di Bari, n. 115, 1978.
3. D. MITARITONNA and G. PRETE: Proposta e sperimentazione di un nuovo sistema di connessione nodale per grigliati spaziali in acciaio. Costruzioni Metalliche, n. 4, 1977.
4. G. PRETE and D. MITARITONNA: Sistema costruttivo PERMIT: criteri di calcolo e modelli applicativi. Atti dell'Istituto di Scienza delle Costruzioni della Università di Bari, n. 116, 1978.
5. M. MEZZINA, G. PRETE and A. TOSTO: Coperture spaziali per stabilimenti enologici in Puglia. Costruzioni Metalliche, n. 5, 1978.