

Zeitschrift: IABSE congress report = Rapport du congrès AIPC = IVBH
Kongressbericht

Band: 11 (1980)

Artikel: Cable systems for bridges

Autor: Gimsing, Niels J.

DOI: <https://doi.org/10.5169/seals-11344>

Nutzungsbedingungen

Die ETH-Bibliothek ist die Anbieterin der digitalisierten Zeitschriften. Sie besitzt keine Urheberrechte an den Zeitschriften und ist nicht verantwortlich für deren Inhalte. Die Rechte liegen in der Regel bei den Herausgebern beziehungsweise den externen Rechteinhabern. [Siehe Rechtliche Hinweise.](#)

Conditions d'utilisation

L'ETH Library est le fournisseur des revues numérisées. Elle ne détient aucun droit d'auteur sur les revues et n'est pas responsable de leur contenu. En règle générale, les droits sont détenus par les éditeurs ou les détenteurs de droits externes. [Voir Informations légales.](#)

Terms of use

The ETH Library is the provider of the digitised journals. It does not own any copyrights to the journals and is not responsible for their content. The rights usually lie with the publishers or the external rights holders. [See Legal notice.](#)

Download PDF: 02.04.2025

ETH-Bibliothek Zürich, E-Periodica, <https://www.e-periodica.ch>



VIII

Cable Systems for Bridges

Systèmes de câbles pour les ponts

Kabelsysteme für Brücken

NIELS J. GIMSING

Professor

Technical University of Denmark

Copenhagen, Denmark

SUMMARY

It is shown that the application of a fan shaped cable system will reduce the amount of cable steel significantly compared to the suspension system. Furthermore, it is shown that the earth anchoring of the back stay in a fan shaped cable system can reduce the normal forces acting on the stiffening girder.

RESUME

Il est montré qu'un système de câbles en forme d'éventail permet une réduction importante du poids des câbles par rapport au système suspendu. En outre, il est montré que l'ancrage dans le sol du câble d'arrêt d'un système de câbles en éventail peut réduire les forces normales agissant dans la poutre.

ZUSAMMENFASSUNG

Es wird gezeigt, dass mit einer büschelförmigen Kabelanordnung eine bedeutende Gewichtseinsparung der Kabel erbracht werden kann, wenn diese mit der herkömmlichen Kabelanordnung der Hängebrücken verglichen wird. Zusätzlich wird gezeigt, dass bei einer büschelförmigen Kabelanordnung eine Erdverankerung der äusseren Schrägseile eine Reduktion der im Brückenträger vorhandenen Normalkraft erzielt werden kann.

INTRODUCTION

In cable supported bridges, the cable system is generally designed for dead load and for traffic load distributed over the whole span length. Applying uniform load to the cable systems will therefore give a good picture of the efficiency of the different systems.

In this paper, the following three cable systems will be treated: (a) The Suspension System, (b) The Fan System and (c) The Harp System, shown in Figure 1 as pure cable systems with all elements in tension.

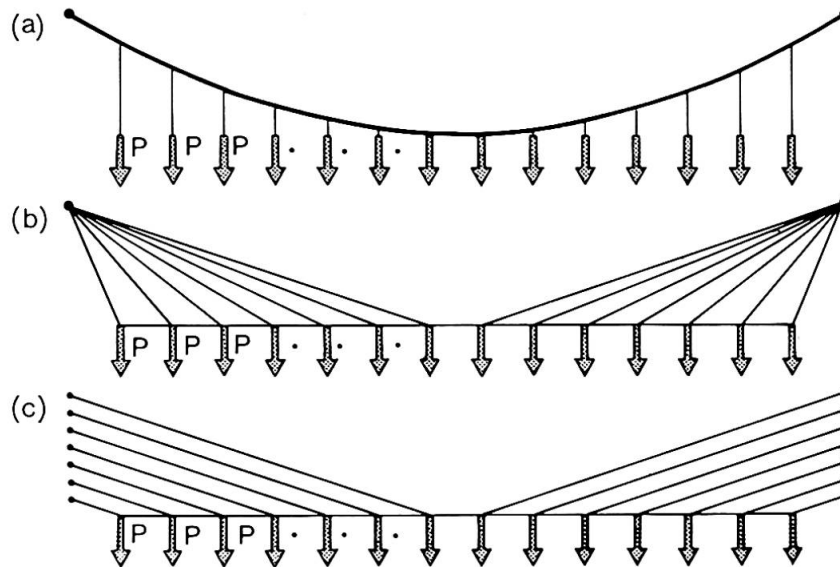

Figure 1. Suspension System, Fan System and Harp System as pure Cable Systems.

The theoretical quantity of cable steel Q_C for a given cable system can be determined by the summation: $Q_C = \sum (\gamma/\sigma) N \lambda$, where N is the cable force, λ the length of each cable element, γ the density of the cable material and σ the limiting stress (allowable cable stress).

THE SUSPENSION SYSTEM

For a suspension system, the right half of which is shown in Figure 2, the quantity of cable steel Q_{CS} can be determined as follows:

$$Q_{CS} = 2 \frac{\gamma}{\sigma} P \left[\frac{1}{4} n(n+1) \frac{a^2}{h} + \sum_{i=1}^n \frac{i(i-1)}{n(n+1)} h + \sum_{i=1}^n \frac{n(n+1)}{2h} \left(a^2 + \frac{4h^2}{n^2(n+1)} z^2 i^2 \right) \right]$$

where the first term is the quantity of the cable 0-1, the second term the quantity of the hangers (summation of $i-i'$) and the third

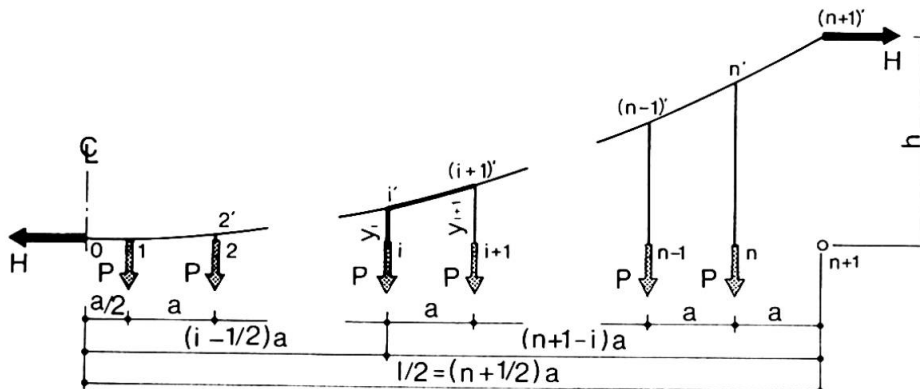

Figure 2. Geometry and Nomenclature for the Suspension System.

term the quantity of the main cable $1-(n+1)'$ (summation of $i'-(i+1)'$).

$$Q_{CS} = 2nP(h + (n + 1) (2n + 1) \frac{a^2}{4h}) \frac{\gamma}{\sigma} \tag{1}$$

THE FAN SYSTEM

For a fan system as shown in Figure 3:

$$Q_{CF} = 2 \frac{\gamma}{\sigma} P (\sum_{i=1}^n (n - i + 1) (i - \frac{1}{2}) \frac{a^2}{h} + \sum_{i=1}^n [(n - i + 1)^2 a^2 + h^2] \frac{1}{h})$$

the first term being the summation of $0-i$ and the second the summation of $i+1 - (n+1)'$.

$$Q_{CF} = 2nP(h + (n + 1) (2n + 1) \frac{a^2}{4h}) \frac{\gamma}{\sigma} \tag{2}$$

thus leading to exactly the same expression as (1).

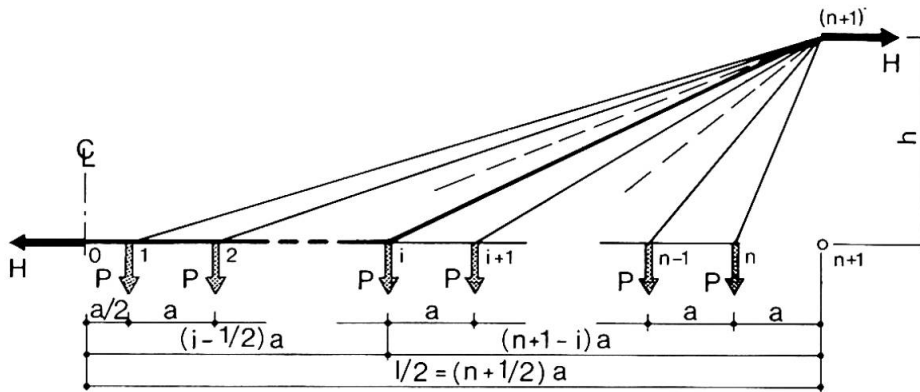

Figure 3. Geometry and Nomenclature for the Fan System

THE HARP SYSTEM

For a harp system (Figure 4) the horizontal force H will be the same as for the suspension and fan systems if $b = 2h/(n + 1)$. In this case, the quantity of cable steel Q_{CH} will be:

$$Q_{CH} = 2 \frac{\gamma}{\sigma} \frac{P}{h} [\sum_{i=1}^n \frac{1}{2} (n + 1) (i - \frac{1}{2}) + \sum_{i=1}^n \frac{1}{2} (n + 1) (a^2 + \frac{4h^2}{(n + 1)^2}) (n + 1 - i)]$$

the first term being the summation of $0-i$ and the second the summation of $i-i'$

$$Q_{CH} = 2nP(h + (n + 1) (2n + 1) \frac{a^2}{4h}) \frac{\gamma}{\sigma} \tag{3}$$

again the same expression as (1)

THEOREM ON THE CONSTANCY OF THE QUANTITY OF CABLE STEEL

From the above investigations the following theorem can be deducted:

The theoretical quantity of cable steel is the same for the suspension system, the fan system and the harp system under uniform load provided they are all made as pure cable systems (with all elements in tension) and with the same horizontal force.

This result might seem to be astonishing as several other investigations have revealed that the quantity of cable steel in the cable stayed systems is considerably lower than in the suspension system. However, the explanation on this divergency is that in the cable

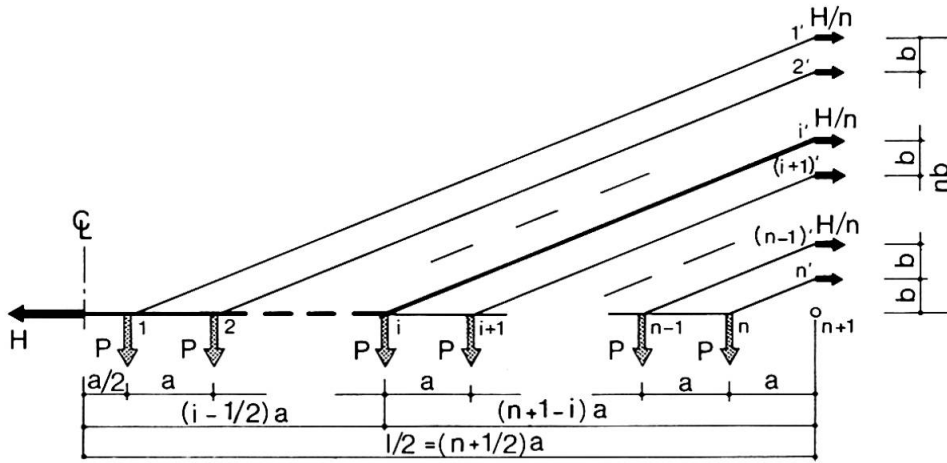

Figure 4. Geometry and Nomenclature for the Harp System

stayed systems only the inclined elements are made of cable steel, whereas the horizontal elements are formed by the stiffening girder.

CABLE STEEL OF THE FAN SYSTEM

Assuming that only the inclined elements of the fan system (the stays) are made of cable steel leads to the following quantity:

$$Q_{CFs} = 2 \frac{\gamma}{\sigma} P \sum_{i=1}^n [(n-i+1)^2 a^2 + h^2] \frac{1}{h} = 2nP(h + (n+1)(2n+1) \frac{a^2}{6h}) \frac{\gamma}{\sigma} \quad (4)$$

For a multi-cable system with a large number of stays, the value for $n \rightarrow \infty$ can be used with sufficient accuracy:

$$Q_{CFs} = pl(h_F + \frac{l^2}{12h_F}) \frac{\gamma}{\sigma} \quad (5)$$

where p is the load per unit length, l the span length and h_F the height of the fan system.

Using the same procedure for the suspension system leads to:

$$Q_{CS} = pl(h_S + \frac{l^2}{8h_S}) \frac{\gamma}{\sigma} \quad (6)$$

where h_S is the height of the suspension system.

The ratio ϕ between the quantity of cable steel in the fan system and in the suspension system can consequently be expressed by:

$$\phi = \frac{Q_{CFs}}{Q_{CS}} = \frac{2l^2 + 24h_F^2}{3l^2 + 24h_S^2} \frac{h_S}{h_F} \quad (7)$$

With the realistic values $h_S/l = 0.1$ and $h_F/h_S = 1.5$, ϕ becomes 0.52, e.g. the cable steel for the fan system is only about half of that needed for the suspension system.

NORMAL FORCES IN THE STIFFENING GIRDER OF THE FAN SYSTEM

In Figure 5, three different structural systems for a 3-span bridge with fan shaped cable systems are shown.

In system A the stiffening girder has expansion joints at the pylons and fixed bearings at the ends giving a system corresponding to the pure cable system with tension in all elements.

In system B the stiffening girder is continuous and with movable bearings at the ends, giving a self anchored system with compression in the stiffening girder.

SYSTEM A

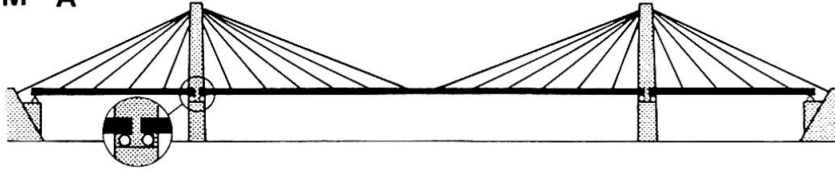

SYSTEM B

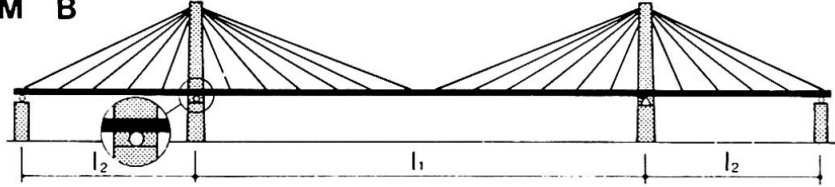

SYSTEM C

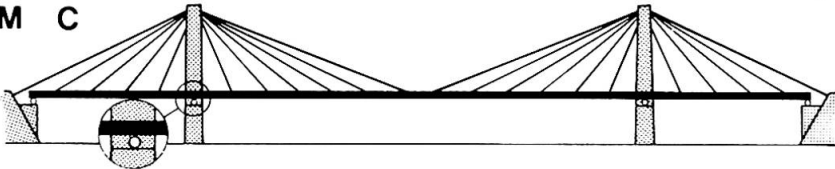

Figure 5. Structural Systems for Bridges with Fan Shaped Cable Systems.

In system C the back stay is anchored to an anchor block, and the stiffening girder continuous with movable bearings at the ends. In this case the stiffening girder will be subjected to both tension and compression.

The variation of the normal force in the stiffening girder is determined by integrating $dN = p(x/h)dx$, where dN is the normal force produced by the load pdx in the distance x from the pylon. For system A: $N=0$ at the pylons, for systems B: $N=0$ at the centre of the main span, and for system C: $N=A$ at the ends.

System A: $N(x) = \int_0^x dN = \frac{1}{2} \frac{P}{h} x^2$

System B: $N(x) = -\int_{l_1/2}^x dN = \frac{1}{2} \frac{P}{h} (x^2 - \frac{l_1^2}{4})$ (8)

System C: $N(x) = -\int_x^{l_2} dN = \frac{1}{2} \frac{P}{h} (x^2 - l_2^2)$

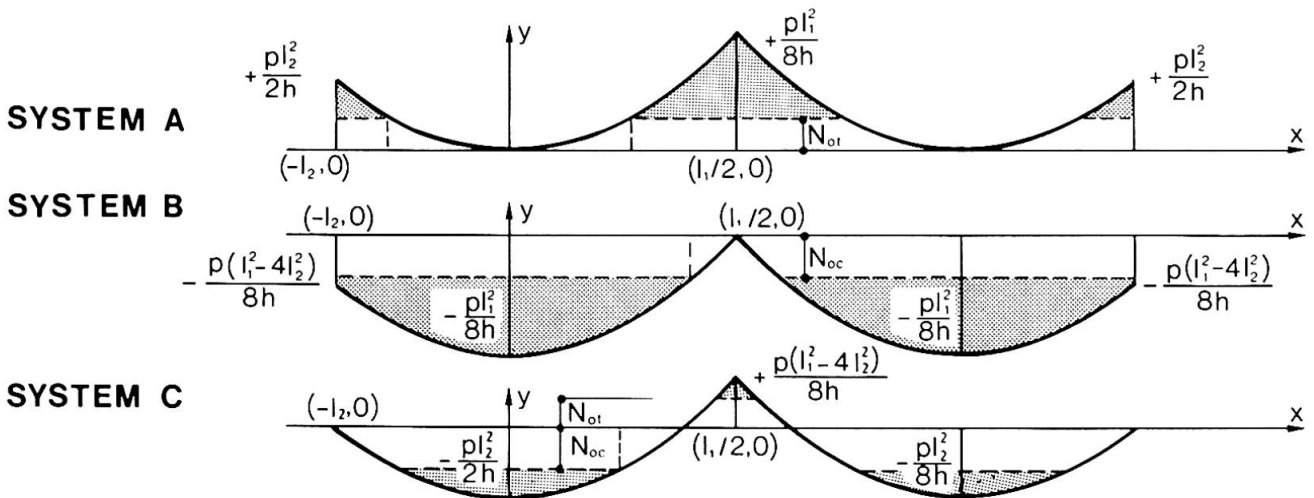

Figure 6. Variation of Normal Forces in the Stiffening Girder for the System shown in Figure 5.

In Figure 6 this variation of the normal forces is indicated.

The influence of the normal forces on the quantity of additional steel in the stiffening girder can approximately be expressed by calculating the area under the normal force curve: $A_N = \int |N(x)| dx$. However, as the stiffening girder generally possesses a capability of transmitting normal forces up to a certain value N_0 , without requiring strengthening, only the shaded areas in Figure 6 should be included in A_N .

In Figure 7 the variation of A_N with the span length l is shown. Note that system B will be considerably more material consuming than the other systems for span lengths exceeding the value l_0 . For $l = 4l_0$ the additional material required in the stiffening girder of system B will be more than 8 times larger than for system C.

It should, however, be considered that the more expensive stiffening girders of system B will in many cases be balanced out by the cheaper substructure subjected to vertical forces only. This is especially true for smaller spans, as those found in the present cable stayed bridges.

With increasing spans the savings in the superstructure of system C will probably make this the optimum solution unless the soil conditions are extremely unfavourable for the construction of anchor blocks.

System A will in no cases be superior to system C.

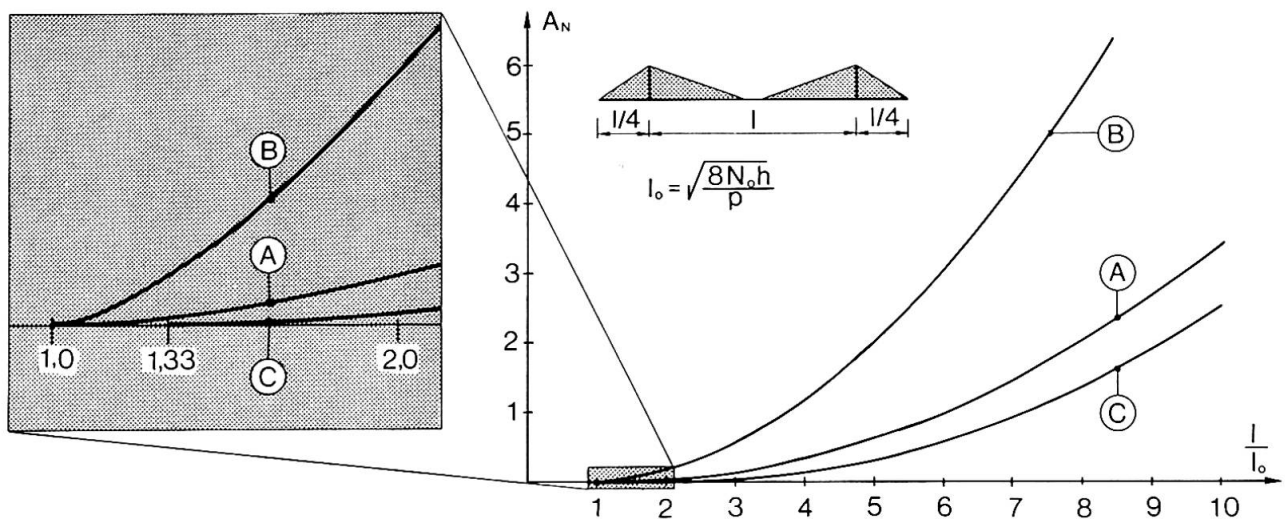

Figure 7. Intensity of the Normal Force Acting on the Stiffening Girder.

REFERENCES

- Gimsing, N.J. : Anchored and Partially Anchored Stayed Bridges. Proceedings of the Symposium on Suspension Bridges, Lisbon, LNEC, 1966.
- Leonhardt, F. : Latest Developments of Cable-Stayed Bridges for Long Spans, Bygningsstatistiske Meddelelser, Copenhagen, Vol. 45, 1974, No. 4.