

**Zeitschrift:** IABSE structures = Constructions AIPC = IVBH Bauwerke  
**Band:** 4 (1980)  
**Heft:** C-13: Sports halls and stadia

**Artikel:** Grandstand at Goodwood Racecourse (England)  
**Autor:** Bobrowski, J.  
**DOI:** <https://doi.org/10.5169/seals-16535>

### **Nutzungsbedingungen**

Die ETH-Bibliothek ist die Anbieterin der digitalisierten Zeitschriften. Sie besitzt keine Urheberrechte an den Zeitschriften und ist nicht verantwortlich für deren Inhalte. Die Rechte liegen in der Regel bei den Herausgebern beziehungsweise den externen Rechteinhabern. [Siehe Rechtliche Hinweise.](#)

### **Conditions d'utilisation**

L'ETH Library est le fournisseur des revues numérisées. Elle ne détient aucun droit d'auteur sur les revues et n'est pas responsable de leur contenu. En règle générale, les droits sont détenus par les éditeurs ou les détenteurs de droits externes. [Voir Informations légales.](#)

### **Terms of use**

The ETH Library is the provider of the digitised journals. It does not own any copyrights to the journals and is not responsible for their content. The rights usually lie with the publishers or the external rights holders. [See Legal notice.](#)

**Download PDF:** 17.03.2025

**ETH-Bibliothek Zürich, E-Periodica, <https://www.e-periodica.ch>**

### 3. Grandstand at Goodwood Racecourse (England)

*Owner: Goodwood Racecourse Ltd*

*Architect: Howard Lobb Partnership*

*Consultant Architect: Philip Dowson, CBE*

*Engineer: Jan Bobrowski and Partners*

*Contractor: James Longley & Co Ltd*

*Structural Sub-Contractors:*

*Worman-Lyncrete Ltd – Erection Anglian Building*

*Products Ltd – Precasting BBRV Simonbuild Ltd –*

*Suspension Cables and Postensioning*

*Dimensions and arrangement:*

*Total surface: 8,900 m<sup>2</sup>*

*Number of floors: 4*

*Space built: 41,500 m<sup>3</sup>*

*Column spacing: 15 m × 14.4 m*

*Live load excluding permanent load: 5 kN/m<sup>2</sup>*

*Other facilities:*

*31 private boxes with common food preparation facility, 3 bars and space for future restaurant, covered Tote facilities with public circulation areas, toilets, etc.*

*Works duration: 10 months*

*Service date: July 1980*

“Glorious Goodwood” – the very name conjures up all that is best in English racing. Race meetings were started at Goodwood by the 3rd Duke of Richmond in the Spring of 1801, and the racecourse still remains part of the present Duke of Richmond’s estate. However, the historic old grandstand has reached the end of its useful life and has been replaced by a new grandstand of outstanding architectural merit.

To demolish the old building and complete a new cable-stayed structure (Figs. 1a, 1b, 1c) in 10 months called for a fast and simple erection system with most components built under factory conditions to beat the winter (see Fig. 2). Apart from safety, comfort and retention of the “garden party spirit” the new grandstand is also expected to meet stringent requirements with respect to economy and durability.

Heavy masonry structures are no longer economical and painting, patching and other types of maintenance required with steel or timber structures, which were taken for granted in the past, are now expensive and difficult to arrange.

The basic structure consists of prefabricated H-frames and pretensioned double tee flooring, a combination which provided a very rapid form of erection.

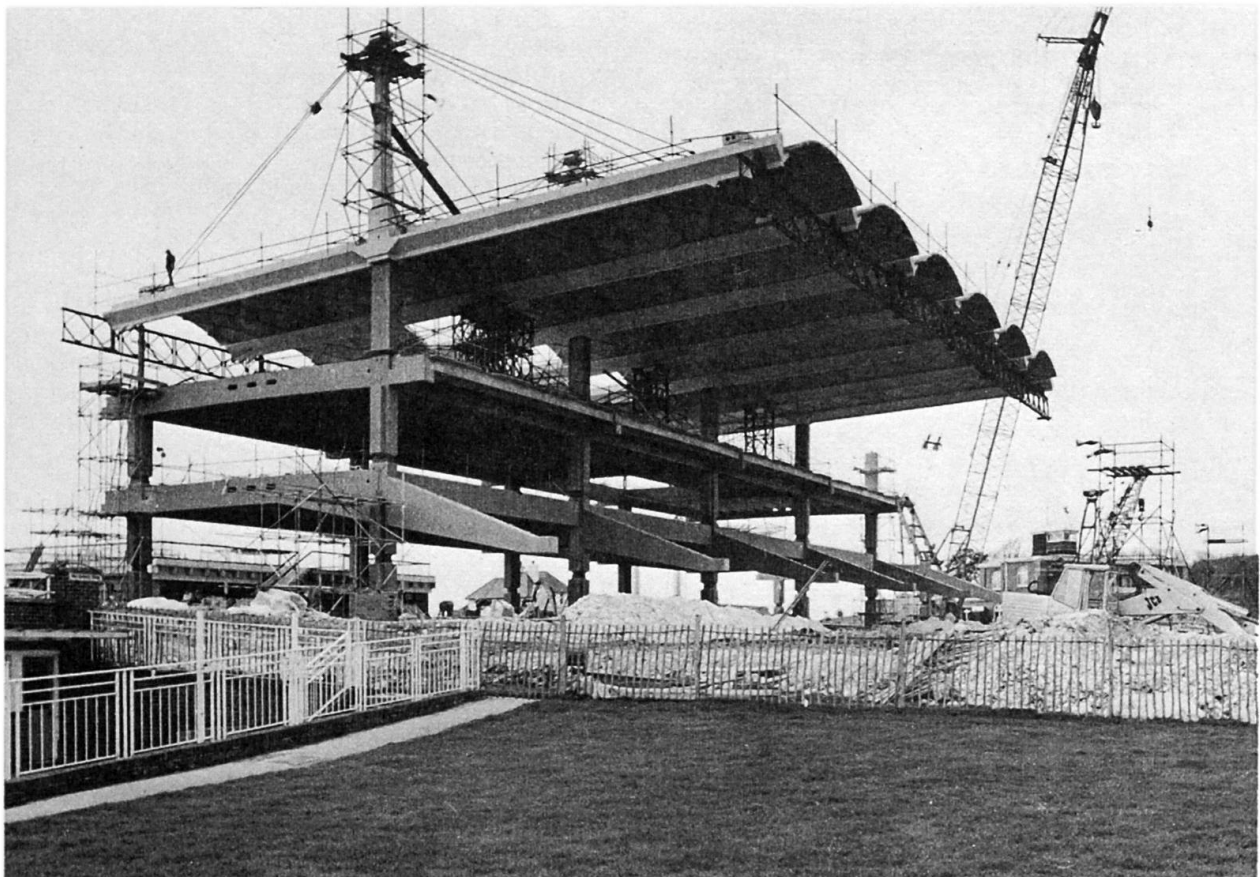

*Goodwood Grandstand*

Special restraints were imposed on the design by the Fine Arts Commission and the Client, requiring that the building should blend with the surrounding countryside and be of slender appearance and maintenance free. To satisfy these criteria it was decided to cable-stay the roof rather than to go for a more traditional cantilever over the front of the grandstand. Austenitic stainless steel cables, designed to be exchangeable if necessary, reduced the size of the 11 inverted roof beams to 1,200 mm depth for 35 m length.

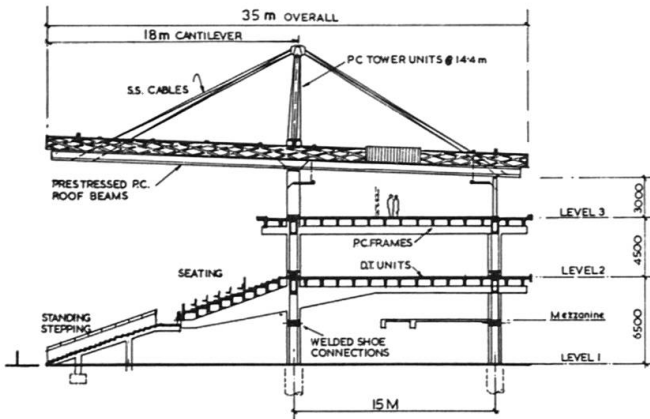

Fig. 1(a) Typical Cross Section

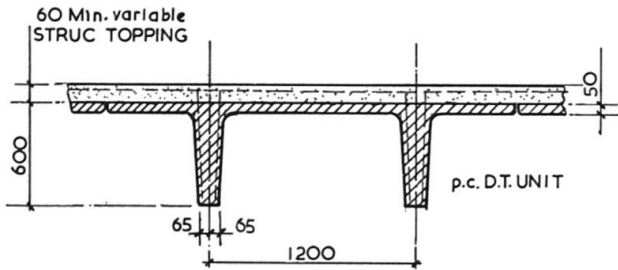

Fig. 1(b) Typical Section Thro D.T. Units

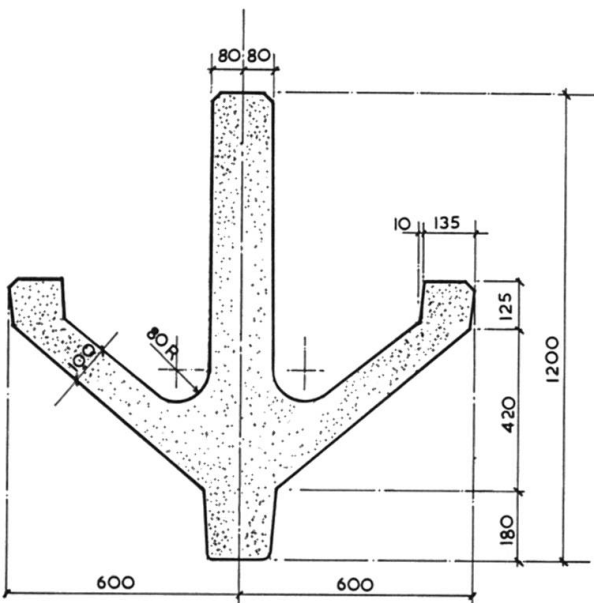

Fig. 1(c) Typical Section Through Pretensioned Roof Unit

Temporary supports were cut to an absolute minimum and match-casting of basic elements ensured perfect fit on site. From each of the 6 pylons above the roof 2 tendons run to the ends of the 6 main beams. A further 6 radiating tendons suspend the intermediate beams. Each tendon comprises 19 austenitic stainless steel-wires of 6 mm diameter. Lightweight concrete shells, 60 mm thick (Fig. 3) span between the main beams.

Such light cantilever constructions are susceptible to wind excitations, particularly due to vortex shedding. Consequently the design provided for the natural frequency of the structure, to differ sufficiently from the frequency of wind loading to avoid resonance. The magnitude of vibration is controlled by the provision of external friction damping at the top of the pylons. Like the cables themselves so the dampers are designed to be exchangeable.

The main body of the structure was erected in about 4 weeks notwithstanding the fact that high winds and exceedingly bad weather lost the contractors about 9 days of this time. The erection sequence of the structure was considered at the design stage and with some components reaching 55 tons in weight it necessitated the use of 350 ton free-on-tracks Grays-ton's Manitowoc crane.

(J. Bobrowski)

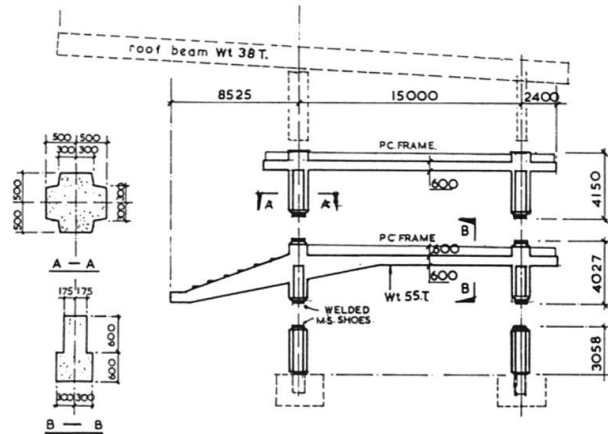

Fig. 2 Elements of Assembly

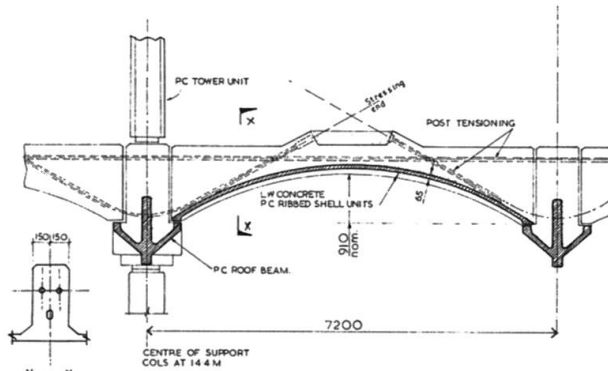

Fig. 3