

Zeitschrift: IABSE structures = Constructions AIPC = IVBH Bauwerke
Band: 8 (1984)
Heft: C-29: Structures in Canada

Artikel: Olympic Saddledome, Calgary (Alberta)
Autor: Bhatia, S.S.
DOI: <https://doi.org/10.5169/seals-18822>

Nutzungsbedingungen

Die ETH-Bibliothek ist die Anbieterin der digitalisierten Zeitschriften. Sie besitzt keine Urheberrechte an den Zeitschriften und ist nicht verantwortlich für deren Inhalte. Die Rechte liegen in der Regel bei den Herausgebern beziehungsweise den externen Rechteinhabern. [Siehe Rechtliche Hinweise.](#)

Conditions d'utilisation

L'ETH Library est le fournisseur des revues numérisées. Elle ne détient aucun droit d'auteur sur les revues et n'est pas responsable de leur contenu. En règle générale, les droits sont détenus par les éditeurs ou les détenteurs de droits externes. [Voir Informations légales.](#)

Terms of use

The ETH Library is the provider of the digitised journals. It does not own any copyrights to the journals and is not responsible for their content. The rights usually lie with the publishers or the external rights holders. [See Legal notice.](#)

Download PDF: 02.04.2025

ETH-Bibliothek Zürich, E-Periodica, <https://www.e-periodica.ch>



8. Olympic Saddledome, Calgary (Alberta)

Owner: *Calgary Olympic Coliseum Society*

Project Manager: *Bill Pratt / Al Olson*

Architect: *Graham McCourt Architects,
Calgary*

**Civil and Structural
Engineer:** *Jan Bobrowski and Partners Ltd.,
Calgary*

**Construction
Manager:** *Cana Construction Co. Ltd.*

Precast Concrete: *Genstar Structures Limited*

**Construction
Time:** *Autumn 1981 to Autumn 1983*

Service Date: *October 1983*

'Olympic Saddledome' provides a distinctive identity for Calgary. Meticulously planned and beautifully executed, it is a superb combination of form and function. Known as the Saddledome because of its double curvature roofline, the 20'000 seat stadium has been built as the flagship of the facilities for the 1988 Winter Olympic Games as well as the future home of the Calgary Flames of the National Hockey League.

The concept of the Saddledome was evolved from a sphere intersected by a hyperbolic paraboloid surface that forms the roof and by a flat plane that forms the base. The curve of the intersection between the sphere and the hyperbolic paraboloid defines the ring beam for the roof. The total volume of the Saddledome, by adopting this form, is indeed about 50% smaller than the average American coliseum yet it will accommodate, in comfort, almost 3'000 more spectators and make significant contribution to energy conservation. The shape of the hyperbolic paraboloid roof correlates closely with the sightlines.

The development of a concept from the spherical shape enables the rational use of prefabrication, particularly

precast concrete. The external columns of the Saddledome, following paths of identical meridians, have all been cast in a single form. Internally, wide use was made of standard double tee floor elements and standard bleachers involving more than 1000 repetitions.

The extensive use of semi-lightweight and extra lightweight concrete enabled the lifting of large elements by cranes of limited capacity, as well as practical resolution of problems arising from uniquely large and rapid temperature oscillations characteristic to Calgary's climate.

The roof structure consists of two sets of cables forming a rigid network of 6 m × 6 m grid on top of which 391 precast concrete roof panels of extra lightweight concrete are placed. The sagging cables are forced to remain parallel to each other and dip about 14 m in the centre. The hogging cables are laid on top of the sagging cables and are permitted to assume their free geodesic shape, ensuring perfect meshing of the 6 m square precast panels. Stressing is carried out in two stages. After the first stage stressing, precast panels are placed over the cables. After the second stage, the narrow strip between the precast panels is filled with cast-in-place concrete that turns the roof into a solid thin shell. No falsework is required for any operation.

To contend with deflections caused by wind and snow loads as well as extreme temperature fluctuations, the roof is designed to float on top of circular external columns by means of multidirectional bearings which transfer only vertical loads. The only place where the roof is fixed is at the two low points where rigid A-frames in pairs are used to resist the lateral loads from the roof. The ring beam at high points can move horizontally up to ±150 mm. Four bearings at each high side are also designed for uplift force.

Monitoring of deflections of the roof structure carried out during each stage of construction indicated an extremely close correlation between the actual field measurements and the theoretical analyses.

(S.S. Bhatia)



Fig. 5 *Calgary Olympic Saddledome*

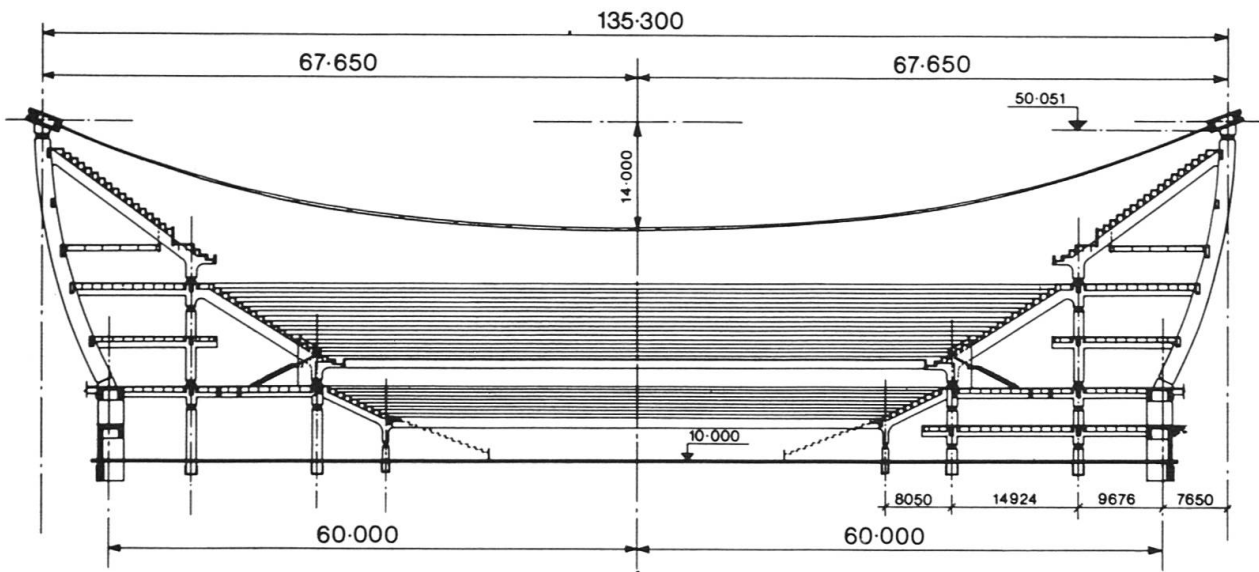

Fig. 1 Cross section

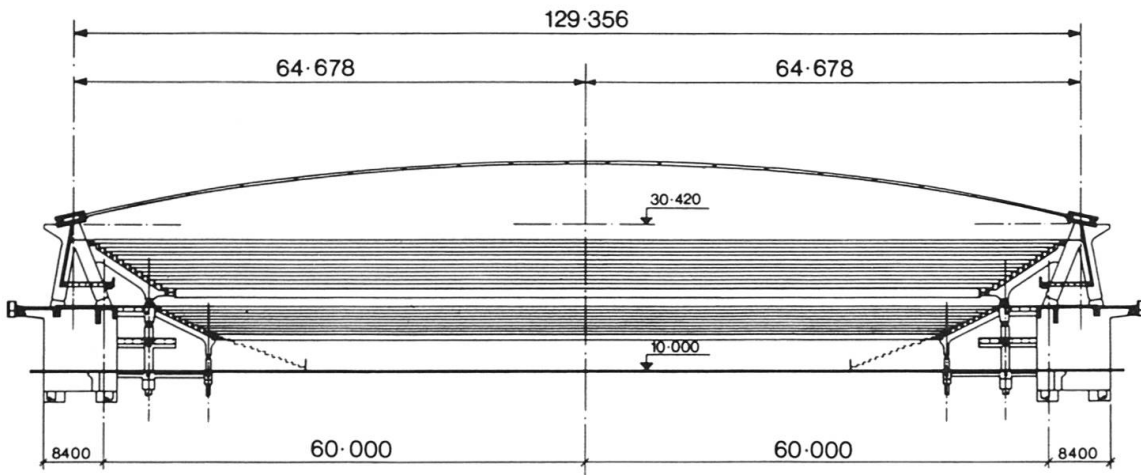

Fig. 2 Cross section

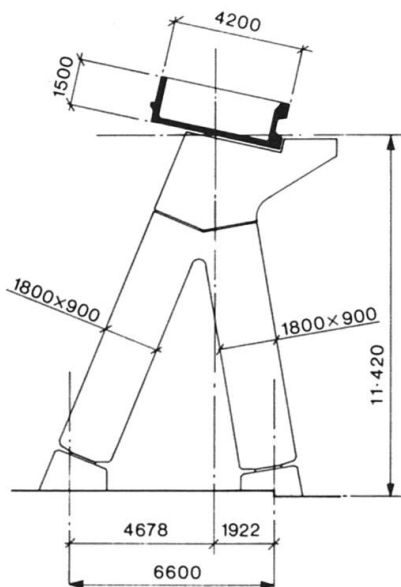

Fig. 3 Typical "A" frame elevation

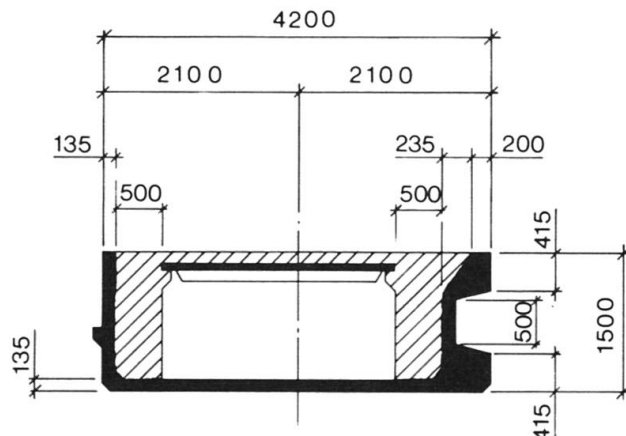

Fig. 4 Typical cross section thru ring beam