

**Zeitschrift:** IABSE structures = Constructions AIPC = IVBH Bauwerke  
**Band:** 8 (1984)  
**Heft:** C-32: Recent structures

## **Werbung**

### **Nutzungsbedingungen**

Die ETH-Bibliothek ist die Anbieterin der digitalisierten Zeitschriften. Sie besitzt keine Urheberrechte an den Zeitschriften und ist nicht verantwortlich für deren Inhalte. Die Rechte liegen in der Regel bei den Herausgebern beziehungsweise den externen Rechteinhabern. [Siehe Rechtliche Hinweise.](#)

### **Conditions d'utilisation**

L'ETH Library est le fournisseur des revues numérisées. Elle ne détient aucun droit d'auteur sur les revues et n'est pas responsable de leur contenu. En règle générale, les droits sont détenus par les éditeurs ou les détenteurs de droits externes. [Voir Informations légales.](#)

### **Terms of use**

The ETH Library is the provider of the digitised journals. It does not own any copyrights to the journals and is not responsible for their content. The rights usually lie with the publishers or the external rights holders. [See Legal notice.](#)

**Download PDF:** 02.04.2025

**ETH-Bibliothek Zürich, E-Periodica, <https://www.e-periodica.ch>**



**Belags-Sickerwasser-Ableiter**

*Subsurface Seepage.*  
**Evacuacions des eaux et aérations.**  
*Ductos de agua de filtración para calzadas.*

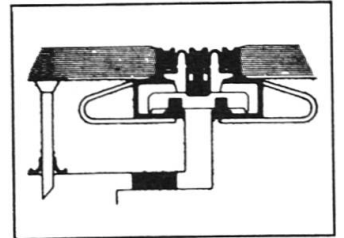

**Fahrbahn-Übergangs-Konstruktionen.**  
*Expansion joints.*  
**Raccordements de chaussées**  
*Sistemas de juntas de dilatación.*

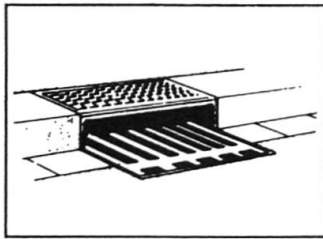

**Entwässerungs-Systeme**

*Surface drainage*  
**Evacuacions des eaux**  
*Pozos de drenaje*

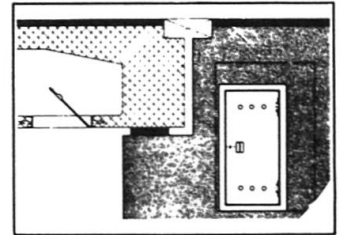
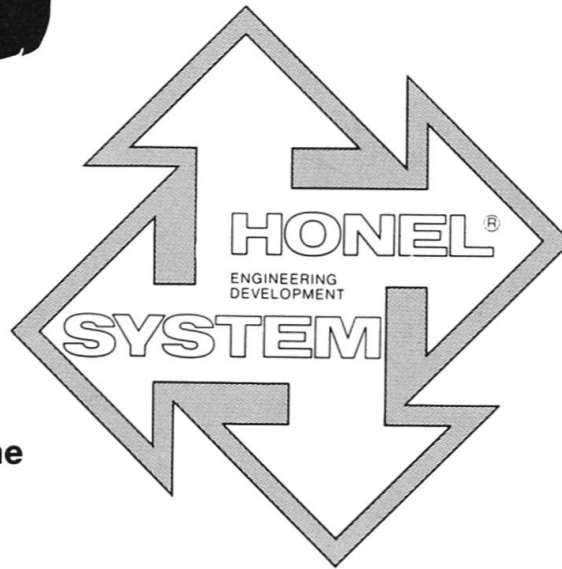

**Hohlraumschalungen**  
**Einstiegsluken + Türen**  
*Formwork + Moulds*  
*Access openings*  
**Ouvertures d'entrée**  
*Aberturas de entrada*

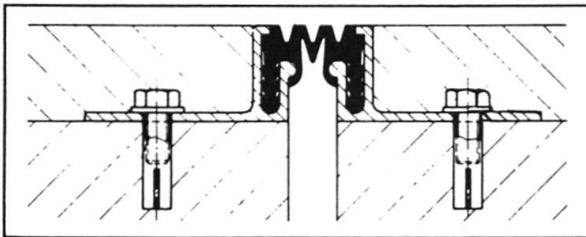

**Fugendichtungen im Hoch- + Tiefbau**  
*Joint seals + Joint profilés*  
**Sellos para juntas**

**Auflager**  
*Structural*  
*Bearings*  
**Appuis**  
*Apoyos*

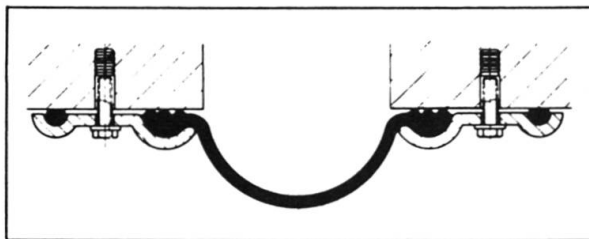
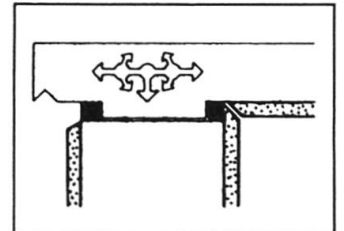

**Pressen + Pumpen**  
*Hydraulic jacks*  
**Verins + Pompes**  
*Prensas + bombas*



**heinz honegger ag**

CH-8427 Rorbas ZH Switzerland  
 Tel. 01 - 86511 77, Telex 52844

**Vertretungs- und Lizenzvergabe:**

Honel-Holding SA  
 Sonnmatstrasse 6  
 CH-8180 Bülach, Switzerland  
 Phone 01/860 89 43





**Step by step into the future.**

**With Wild instruments into the informatics-age.**



Anyone who has decided to buy a Wild DISTOMAT DI4, DI4L, DI5 or DI20 can now benefit from a further development.

In a DI4, DI4L or DI5, you not only have the smallest infra-red distancer, and in the DI20 the most accurate DISTOMAT with the greatest range, but also the first module of an informatics-age instrument system.

Fit the DISTOMAT on the T2000. The Wild T2000 informatics theodolite supplies it with power, controls it electronically and instantly displays angles and distances, heights and coordinates, paired in various convenient ways.

With tracking, setting-out and traverse programs, the T2000/DISTOMAT combination is a high-performance, high-precision field-survey system.

Add the user-programmable GRE3 data terminal and you have a data-acquisition and data-handling system that makes the vast capabilities of the informatics age available to you. ■

G 68-83

Wild Heerbrugg Ltd · CH-9435 Heerbrugg · Switzerland · Telex 881 222

**WILD**  
**HEERBRUGG**



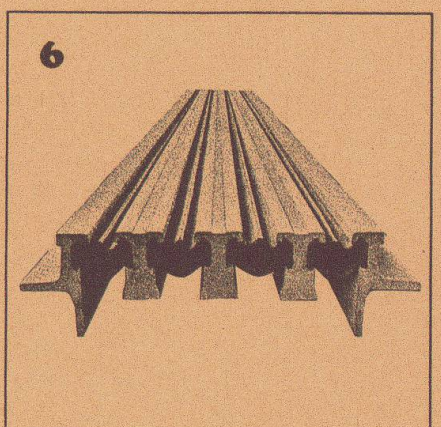
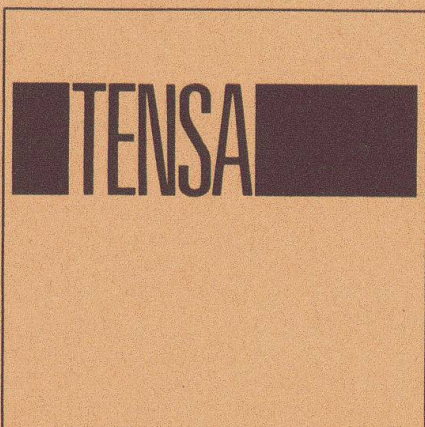
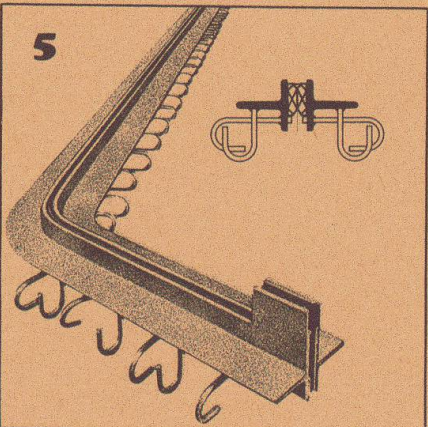
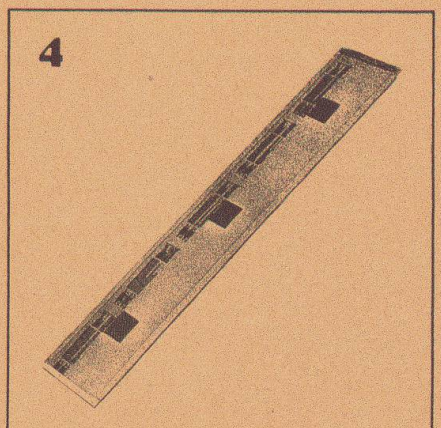
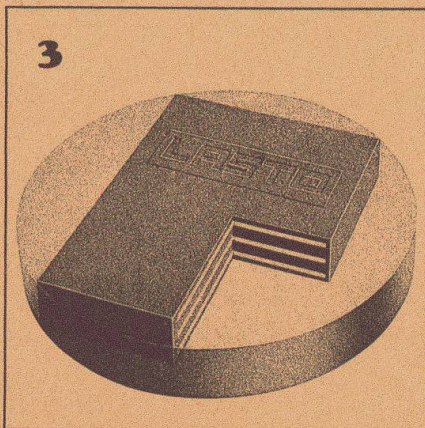
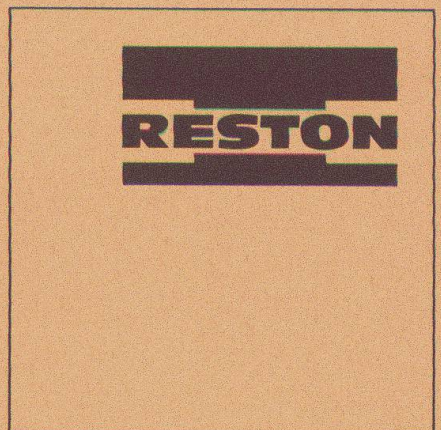
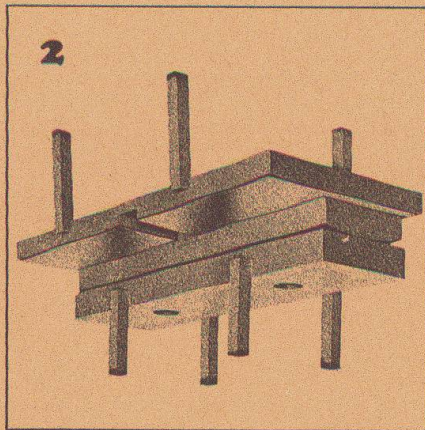
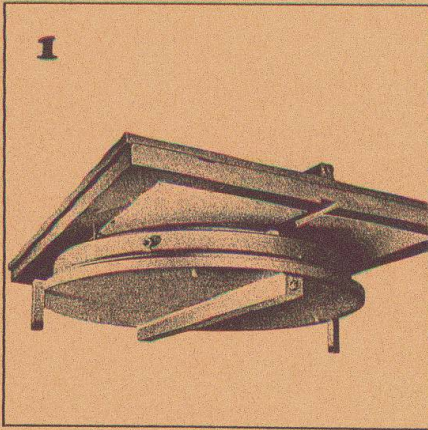

1

**RESTON Pot Sliding Bearings** are highly suitable for installation in bridge structures. They feature a low-profile design, low weight and high loading capacity.

2

**RESTON Linear Tilting and Sliding Bearings** are a combination of normal linear tilting bearings and PTFE sliding bearings and are suitable for installation in bridge structures.

3

**LASTO-BLOCK Bearings** are suitable for building, civil engineering and bridge construction applications. Their simple form allows easy installation.

4

**LASTO-STRIP Bearings for Buildings** were especially developed for building constructions. They are particularly suitable for movement compensation between concrete slabs and load-supporting walls and prevent structural cracking.

5

**TENSA-ACME Roadway Construction Joints** are highly suitable for installation in traffic levels (parking lots, bridges, airport areas etc.). Dilatation up to 60 mm.

6

**TENSA-LASTIC Roadway Construction Joints** meet all the requirements that can be made in bridge engineering of a modern joint design. They are rugged and watertight. Dilatation range 60 mm and bigger.

PROCEQ SA  
Riesbachstrasse 57  
CH-8034 Zurich

proceq

Phone: 01/47 7800  
Telex 53357 proce ch