

Zeitschrift: IABSE structures = Constructions AIPC = IVBH Bauwerke
Band: 13 (1989)
Heft: C-48: Structures in Portugal

Artikel: International Guadiana Bridge (Portugal - Spain)
Autor: Martins, J. Cândia
DOI: <https://doi.org/10.5169/seals-21552>

Nutzungsbedingungen

Die ETH-Bibliothek ist die Anbieterin der digitalisierten Zeitschriften. Sie besitzt keine Urheberrechte an den Zeitschriften und ist nicht verantwortlich für deren Inhalte. Die Rechte liegen in der Regel bei den Herausgebern beziehungsweise den externen Rechteinhabern. [Siehe Rechtliche Hinweise.](#)

Conditions d'utilisation

L'ETH Library est le fournisseur des revues numérisées. Elle ne détient aucun droit d'auteur sur les revues et n'est pas responsable de leur contenu. En règle générale, les droits sont détenus par les éditeurs ou les détenteurs de droits externes. [Voir Informations légales.](#)

Terms of use

The ETH Library is the provider of the digitised journals. It does not own any copyrights to the journals and is not responsible for their content. The rights usually lie with the publishers or the external rights holders. [See Legal notice.](#)

Download PDF: 02.04.2025

ETH-Bibliothek Zürich, E-Periodica, <https://www.e-periodica.ch>



1. International Gadiana Bridge (Portugal – Spain)

Owner: Highway State Administrations of Portugal and Spain

Engineers: J. L. Cândia Martins, Lda

Contractors: Teixeira Duarte Lda
Huarte y Cia SA
Hasa

Works duration: 30 months

Service date: 1991

General

The bridge under construction near Castro Marim (Portugal) and Ayamonte (Spain) will be one of the most important connections between the Portuguese and the Spanish road systems. At present the crossing is made by ferry. Bad soil conditions worsened by the possibility of liquefaction under seismic loads lead to the choice of a cable-stayed bridge.

Bridge Deck

The prestressed concrete bridge deck consists of a continuous girder over 666 m with a main span of 324 m. The spans suspended by cables every 9 m have a single cell box girder as gross section stiffened by diagonal struts every 4.50 m. The transition spans between piers and abutments have the same cross section but due to their support conditions two inside beams replace the stiffening struts. The deck will be constructed out of 4.50 m long cast-in-place segments. It will be fully prestressed, a request made by the owner.

Pylons

The A – shaped pylons (P2, P3) will have a height of approximately 100 m above water level. Each leg is supported by a massive pile cap on 13 cast-in-place steel lined concrete piles with a diameter fo 200 cm.

At pylon 3 piles with an average length of 50 m will be used.

Stay cables

The stay cables are made of 15 mm strands, their number varying between 22 and 55. They are anchored at the deck and at the pylons.

(J. Cândia Martins)

Quantities

Concrete

Infrastructure	13 000 m ³
Superstructure	7 900 m ³

Reinforcing steel

Infrastructure	700 t
Superstructure	1 000 t

Prestressing steel

Infrastructure	160 t
Superstructure	400 t

Stay cables

530 t



Fig 1 Composite picture

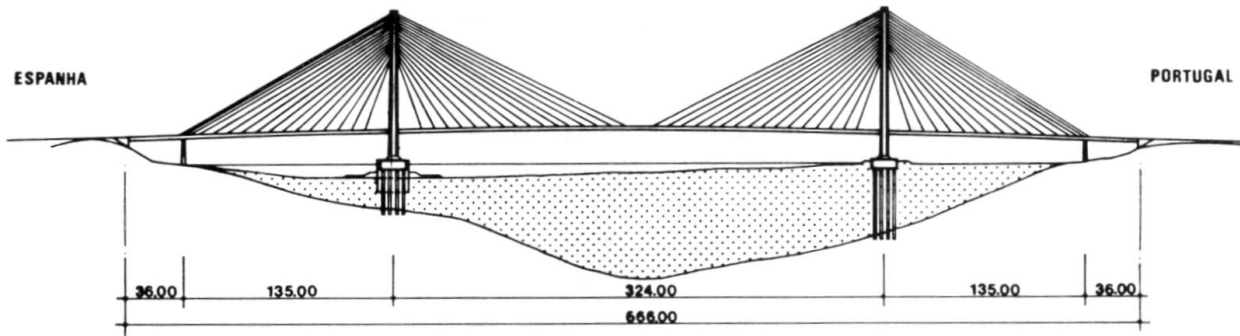

Fig. 2 Side view of the bridge

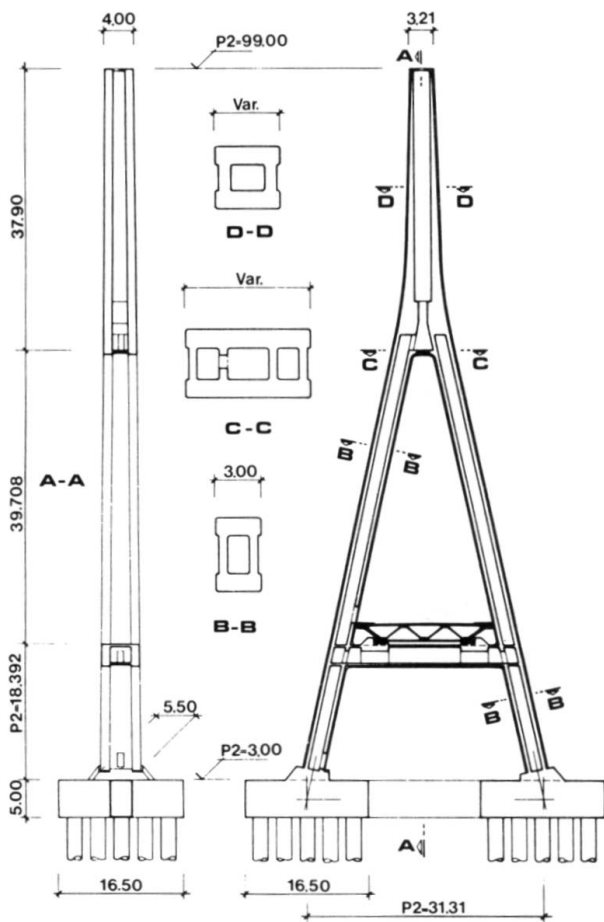

Fig. 3 Geometry of the pylons

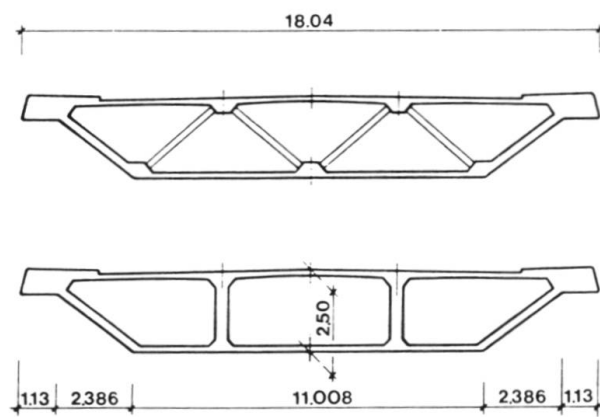

Fig. 4 Cross-section of the deck