

Zeitschrift: IABSE journal = Journal AIPC = IVBH Journal
Band: 10 (1986)
Heft: J-30: Renewal of the old Quaibrücke in Zurich

Artikel: Renewal of the old Quaibrücke in Zurich
Autor: Fechtig, Robert
DOI: <https://doi.org/10.5169/seals-28994>

Nutzungsbedingungen

Die ETH-Bibliothek ist die Anbieterin der digitalisierten Zeitschriften. Sie besitzt keine Urheberrechte an den Zeitschriften und ist nicht verantwortlich für deren Inhalte. Die Rechte liegen in der Regel bei den Herausgebern beziehungsweise den externen Rechteinhabern. [Siehe Rechtliche Hinweise.](#)

Conditions d'utilisation

L'ETH Library est le fournisseur des revues numérisées. Elle ne détient aucun droit d'auteur sur les revues et n'est pas responsable de leur contenu. En règle générale, les droits sont détenus par les éditeurs ou les détenteurs de droits externes. [Voir Informations légales.](#)

Terms of use

The ETH Library is the provider of the digitised journals. It does not own any copyrights to the journals and is not responsible for their content. The rights usually lie with the publishers or the external rights holders. [See Legal notice.](#)

Download PDF: 02.04.2025

ETH-Bibliothek Zürich, E-Periodica, <https://www.e-periodica.ch>

Renewal of the Old Quaibrücke in Zurich

Rénovation de l'ancien pont «Quaibrücke» à Zurich

Erneuerung der alten Quaibrücke in Zürich

Robert FECHTIG

Professor
Swiss Fed. Inst. of Technology
Zurich, Switzerland

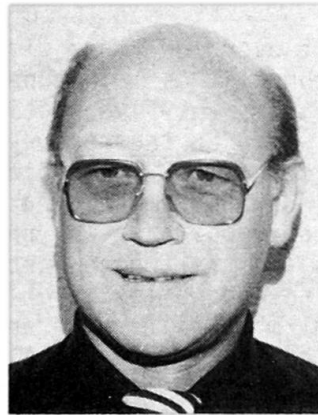

Robert Fechtig, born 1931, got his civil engineering diploma at the Swiss Federal Institute of Technology (ETH) in 1956. Two years in water works construction in Sweden. Two years as a research assistant at the ETH. In construction firm Zschokke 1960–1981, active in the field of large civil engineering projects. Professor of construction engineering and management at the ETH since 1981.

SUMMARY

The renewal of old constructions in city areas and their adaptation to higher requirements presents many difficulties. There is not only the heavy traffic, the small space and the political aspects, but also the question of total or only partial renewal and the connection of existing and new parts. Side by side to the existing bridge a new one with similar form was built and then both were displaced at once. Due to the very precise planning this could be done successfully.

RÉSUMÉ

La rénovation d'anciennes constructions dans le centre de villes et leur adaptation à des exigences plus élevées créent de grands problèmes. Par exemple, les discussions politiques, la question d'une rénovation totale ou seulement partielle, le trafic, le raccordement des parties existantes aux nouvelles. A Zurich on a construit, près d'un pont existant un nouveau pont semblable à l'autre. Puis on les a déplacé tous deux latéralement. Grâce à une planification minutieuse, on a terminé les travaux dans les délais.

ZUSAMMENFASSUNG

Die Erneuerung von alten Bauwerken in innerstädtischem Gebiet und ihre Anpassung an die höheren Anforderungen bieten mancherlei Probleme: die politische Diskussion, das Ausmass der Erneuerung, die Verwendung von bestehenden Teilen, die Verkehrsführung und die Anschlussarbeiten. In Zürich erstellte man neben der bestehenden Quaibrücke eine neue gleichen Aussehens und ersetzte durch gleichzeitiges Verschieben die alte durch die neue Brücke. Dank der minutiösen Vorbereitung konnten die Arbeiten plangerecht ausgeführt werden.



1. INTRODUCTION

Zurich, the largest city of Switzerland, is situated at the lower end of the lake of the same name. Just where the River Limmat leaves the lake, it is crossed by the first of the numerous bridges in Zurich. The Quai-Bridge is a very important junction in the traffic system of the city and the agglomeration. To renew this bridge under most difficult conditions was a very interesting civil engineering problem.

2. HISTORY

The old Quai-bridge is just over 100 years old. In 1882-1884 it was erected by civil engineer Dr. Arnold Bürkli. As main supporting structure six arch-formed steelgirders served which cross the five sections between the piers and counterfort in an elegant way. For the roadway-slab trough-plate had been used as a normal element of construction. The bad underground was a special problem and brought difficulties. The upper most stratum formed by lakemarl and rotten slime is not fit to bear heavy weights. For this reason pile-gratings have been erected for the four piers and the two counterforts. The foundation of each pier is formed by 130 to 150 pine-wood piles which penetrate the lakemarl and are founded on an ice-age stratum of silt, sand and gravel which bears well. During the construction of the rightside counterfort (Bellevue) in February, 1883, one part of the bad lakemarl and rottenslime stratum slid down and damaged the foundation of the next pier. The counterfort itself coused partly. To diminuate the load on the underground, a free space of about 25 m square was erected behind the counterfort. This one is nearly 3 m high and covered with a construction of steel and concrete, which itself is based with cast-ironed supports on small pile-gratings.

Since 1932 an armed concrete-slab substitutes the old construction. At the same time the iron construction was reinforced. On the occasion of the Swiss National Exhibition in 1939 the bridge was enlarged from 20 to 28,5 m. On both sides of the bridge new arched-formed main-steel-beams were erected, so that the number of main beams was raised to 8. Different small alterations have been made at the counterfort. With this modification the bridge received its present appearance.

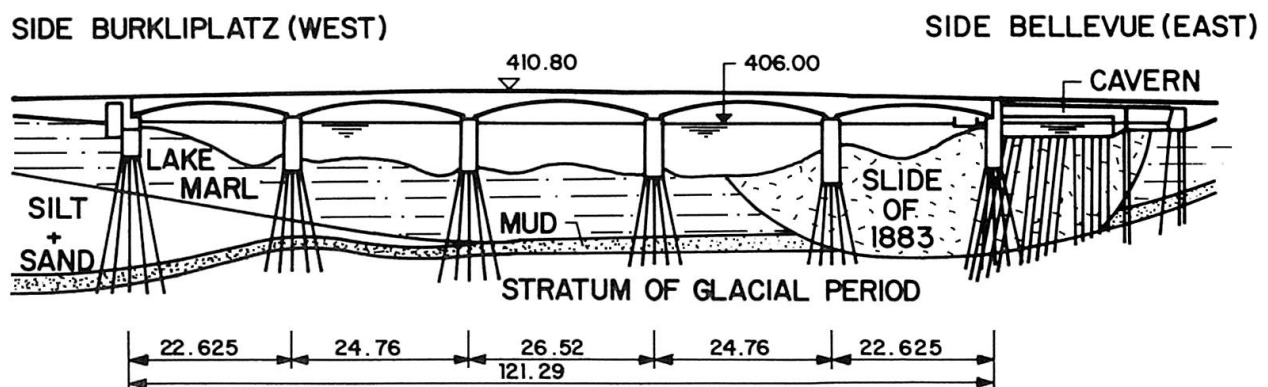

Fig. 1: Longitudinal section with geological cross section

As the cost inquiry was difficult and these costs depended on the construction method chosen by the constructor, the town council, before obtaining the required credit, decided to call for a competition among five civil engineering contractors from Zürich in order to receive information on costs, construction methods and construction time. The promoter finally chose amongst various designs the proposition of the joint venture (=ARGE) Fietz Leuthold/Schneider Stahl- und Kesselbau AG. The deciding criteria was the possibility of minimizing the traffic flow, the short construction time and the possibility to guarantee an optimal construction quality which could be performed without interrupting the traffic flow. On the 26th September 1982 the town council brought forward for voting the contractor's proposition together with an additional request to widen the carriage way slab by 2 m for a cycle track. The proposal including the additional request was accepted. The reconstruction could therefore start.

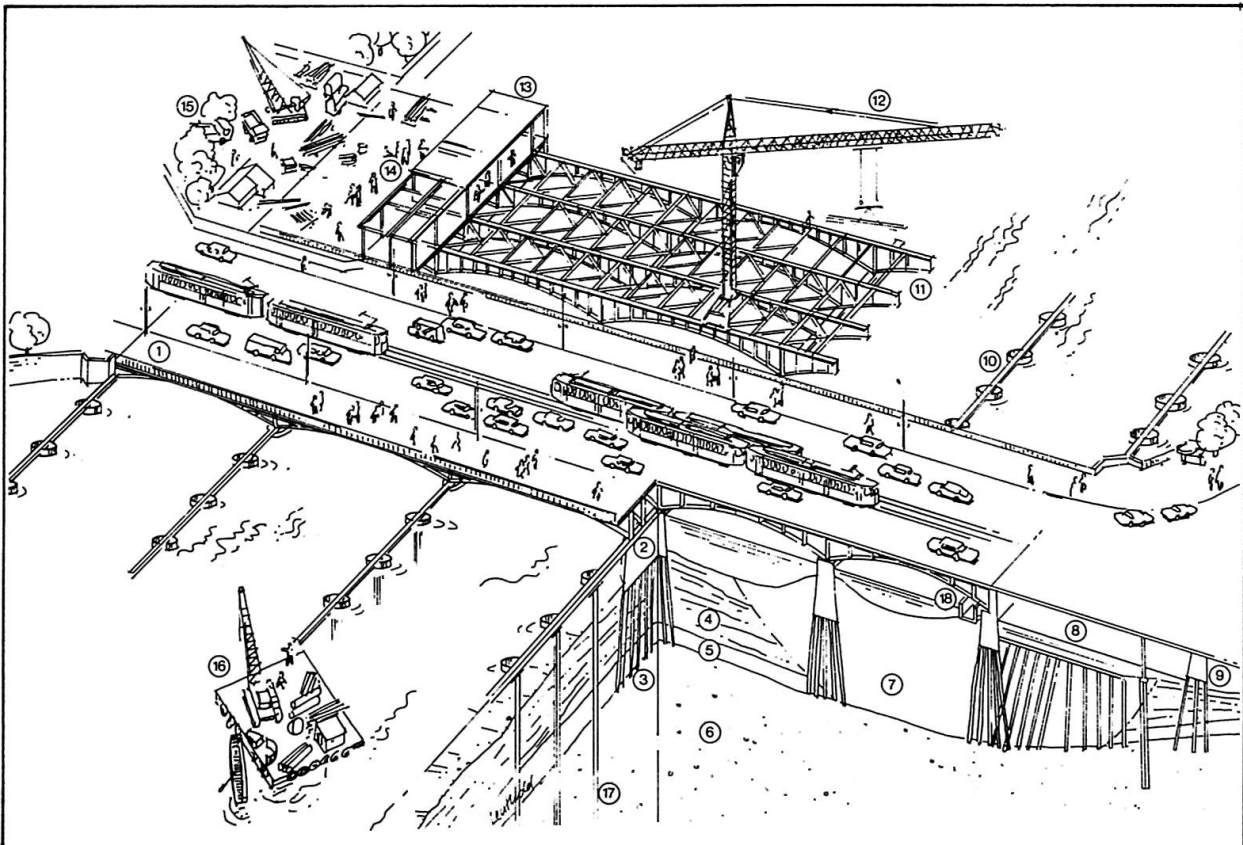

Fig. 2: General view of the work

- | | | | |
|----|--|----|---|
| 1 | old Quaibrücke, built 1882-1884, widened in 1939 | 11 | four new welded steel girders Fe 510, erected on displacement tracks |
| 2 | pier, concrete with abutment of natural stone | 12 | tower crane |
| 3 | pier pile grating | 13 | removable falsework for the concrete slab |
| 4 | lakemarl | 14 | pouring section, length 12 m |
| 5 | mud | 15 | installation site |
| 6 | stratum of glacial period, foundation of the pile gratings | 16 | floating pile driver |
| 7 | slide of 1883 | 17 | piles of displacement track, quantity - 40, \varnothing - 1.22 m length - 25-35 m |
| 8 | Bellevue cavern | 18 | concrete trough for pedestrian underpass |
| 9 | old embankment | | |
| 10 | displacement track | | |



3. REPAIR WORK

Since the last reconstruction, the traffic on the bridge has increased extraordinarily. Nowadays about 50'000 motorcars and about 1500 trams cross the river daily. In the rush-hour more than 4000 cars and 114 trams are counted per hour. The high frequency of traffic, the higher weight capacity of cars, but especially the influence of salt and frost caused extreme damage to the old construction. Even the bad underground has never been stable. Various bigger movements at the right counterfort have been observed. The movement in direction of the River Limmat amounted to 7 cm. The controls made by the divers showed that several pile-heads of the counterfort could not fulfil their bearing function anymore. Both the side walls of the bridge ends the piles were in a similarly bad condition. Expensive repairs of the pile foundations and of the bridge support were necessary. In 1966, 1970 and 1975 several holes in the roadwayslab appeared; this damage was repaired immediately. In 1975 the whole fixation of the tramway rails in the concrete slab had to be renewed.

The steel construction was reinforced in 1932 and 1939. Since then only the most necessary painting to avoid further rusting has been done.

4. NEW PROJECTS

The weakest element of the old bridge is the roadway-slab. The growing maintenance, the bad condition and the augmented stress of the bridge have forced the government of the town to plan a new project. In 1974 the citizens of Zurich voted against the credit for a new bridge-construction. The project showed an enlarged bridge of 34.5 or 42.2 m width. A citizens' initiative demanded the reconstructions of the bridge in the old face and form. And in 1977 the citizens accepted their reconstruction project.

5. BRIDGE RECONSTRUCTION

The town council had to call in an expert-committee in order to receive a breakdown on the condition of the particular parts of the bridge. The committee had to write a reconstruction program. The intention was to attain appropriately the same extent of security, quality and durability for all parts of the bridge. The main elements of the Quaibrücke (roadway slab, steel load bearing system, pier and kentledge with pile foundation and the Bellevue cavern construction) showed different qualities. Following results and conclusions were found by the experts:

- the timberpiles were of sufficient quality and were able to be reused.
- the concrete of the bridge piers was partly porous and the damage resistance varied strongly. The concrete had to be strengthened by injections and the results to be surveyed by drilling controls.
- the steel main supporting structure was cleaned by sand blasting. After local reinforcement and repairs, it could then be protected against corrosion.
- the roadway slab proved to be the weakest part. The experts decided to reconstruct it instead of repairing it.
- the wood pile foundations were re-used within the Bellevue cavern. The pile heads were renewed and the cast-iron columns were encased into concrete. The steel girder grille was reused after the renewal of the corrosion protection and the concrete slab was protected by insulating the surface.

6. THE PROPOSAL OF THE CONTRACTOR

New bridge spans - consisting of four new steel girders and a post-tensioned concrete slab poured on site - are built on displacement tracks and temporary piles in the River Limmat. The traffic circulates on the existing Quai-Bridge during the construction of the new bridge. In the same period, the existing bridge piers are repaired. The new bridge's girder and deck are then shifted to its definite place during a low-traffic weekend; at the same time the existing girders and deck are pushed on displacement tracks and temporary piles to the lake side of the bridge. Finally, the old bridge's girder and deck are demolished as well as the displacement tracks and the temporary piles.

The special construction method characterizes the contractor's proposal. It results in benefits for both the on-going traffic and the construction of the new bridge as well as in a very short construction time which could not be realized with another construction method. The procedure consists of the following activities:

- A platform was built on the Limmat side of the existing bridge near the West abutment. Prefabricated slabs were fixed on driven-in piles. The platform became the access to the new bridge site. The crane that was installed temporarily on the new bridge entered on this platform.
- Then, the temporary piles for the displacement track were drilled into the river ground.
- In the same phase, the existing bridge piers and abutments were repaired with cement injections. Reinforcing tension and compression members were added on top and at the basis of the piers, respectively.
- Now the pile caps and the displacement tracks were installed. The final position of the tracks was partially below the water surface. The temporary structure was now ready for carrying the new bridge.
- The steel girders were placed in 10 major phases, usually during the night. The tower crane was run on a temporary track that was put in corresponding to the advancing working location of the crane.
- As soon as the girders of the first three spans were placed and welded, the first section of the slab was poured on a removable false work. One section of about 12 m took about one week, i.e. 10 sections were necessary for the whole bridge.
- During this work, the piles and displacement tracks on the lake side were finished.
- On the occasion of the pier repair, the supports of the existing girders were replaced by sliding bearings. So the existing bridge was ready for being moved.
- Many utilities were installed below the new bridge deck after this deck had been finished.
- The necessary reinforcing and force distributing elements and the displacement equipment were installed. Some more temporary scaffolds and platforms were added.
- The cavern behind the East (Bellevue) abutment was repaired. The utilities both at the East and West access to the bridge were adapted or constructed.



- The displacement of both the new and the existing bridge took place during one single weekend according to a detailed schedule.
- After the displacement, the deck joints were set and the utilities were linked together. The start of operation was already made possible.
- Finally, the old bridge and the temporary structures (displacement tracks, piles, access platform) were demolished.

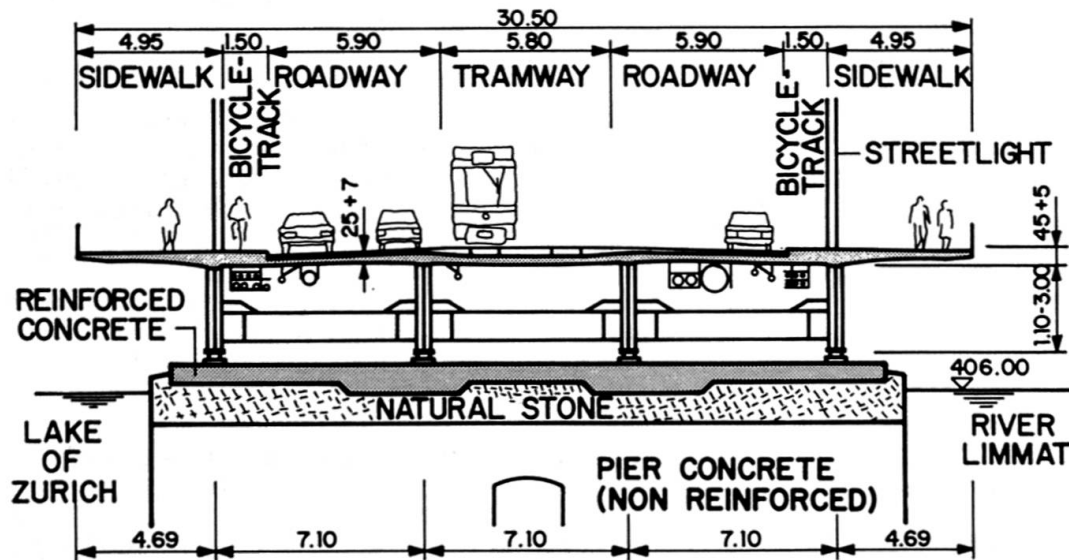

Fig. 3: Cross section of the new bridge with traffic areas

7. CONSTRUCTION METHODS

7.1 Pier repair

The concrete strength of the piers and abutments was improved by injecting cement. The "Colcrete"-method was used to build the compression members. The tension members are 80 cm wide and 60 cm deep. They had to be built in short pieces in a very narrow working space. The existing bridge was temporarily supported by a system of hydraulic jacks that simulated the existing support conditions.

7.2 Displacement tracks

Drilled "Hochstrasser-Weise" piles of 120 cm diameter and a length of 25-35 m were used. Divers widened the pile bases to a diameter of 160 cm to improve their bearing capacity. The bearing pipes remained in the ground to facilitate the pile demolition. The displacement tracks on the temporary piles were welded box girders of HEB 600 profiles for the abutment and HEB 1000 profiles for the pier axes. On the piers, the track is a 600 mm wide steel sheet that is inserted in the tension members.

7.3 Steel girders

The four main girders are made of steel Fe 510. The top flange is 500 mm wide and the bottom flange is 600 mm wide, the thickness is between 25 and 60 mm. The web is 14 or 15 mm thick. The quality of material and welding was controlled by experts. Bracing frames instead of the usual frameworks were used because of the necessary space for the utilities. A two-component coating of 260 p that is built up in 4 layers will protect the girders against corrosion.

7.4 Tower crane

A tower crane placed the girders which had a maximum of 18 tons weight and 26.5 m length. They arrived during the night on the existing bridge and were placed in a very short time. Additional bracing members were necessary to make the overall structure stable.

7.5 Bridge Deck

The cast in place slab is made of reinforced and laterally post-tensioned concrete B PC 325 that should resist frost and anti-freezing salt water. The cables have a distance of 90 cm and a tension of 88 tons. There are no longitudinal cables. The framework and scaffold were pulled on removable rails on the temporary bracing of the steel girders.

7.6 Waterproofing and cover

The deck waterproofing is a reinforced bituminous layer that is covered with an aluminum surface. The waterproofing was head-posted on the complete surface. The cover is a floated mastic asphalt built up in two layers. The thickness is 65 mm on the traffic-way and 55 mm on the side walk. Crushed sand is worked into the coversurface. Waterproofing and covering were determining the construction schedule because of their dependence on good weather conditions.

7.7 Utilities

The new bridge carries many utility pipes and cables: steel pipes of up to 800 mm diameter for water, electrical tube blocs, police communication pipes, a steel pipe for gas, and the rain water drainage system of the deck. The PTT installed a new cable block for telecommunication in the ground of the Limmatt further down the river. Most of the installation work was not visible. This work which had to be done from the surface of traffic areas gave an idea of how impractical a bridge renovation "on site" would have been.

8. DISPLACEMENT PROCEDURE

The displacement procedure is without question the most spectacular construction stage. The weight of both the existing and the new bridge superstructure is 7800 tons, approximately. Up to 100 t of tractive strength have to be applied per pier. The movement happens very slowly with a speed of approximately 2.5 mm/sec. and 25 cm per step. After each meter extensive measurements are made to control the structures. The results of the measurements are compared with the precalculated values. The analytical simulation of the displacement procedure shown on a computer gives exact information on the expected requirements. The piles call for special surveillance, as improper use of the displacement equipment (or instruments) could provoke a horizontal displacement. A guide system allows an exact moving of the bridge into the planned position. Both bridges therefore are manoeuvrable. The displacement works can be divided into three main phases:

- supporting change of the two bridges

The old bridge has to be put on slide supports in order to be able to displace it. The new bridge had already been erected on the tracks. The slide supports are locked onto the displacement track until the displacement starts. The upper part of the support will be used later as a part of the whole support. The old supports of the existing bridge had been exchanged against sliding bearings whereby the existing support conditions had to be followed exactly. These tasks were performed in several stages under heavy traffic flow.

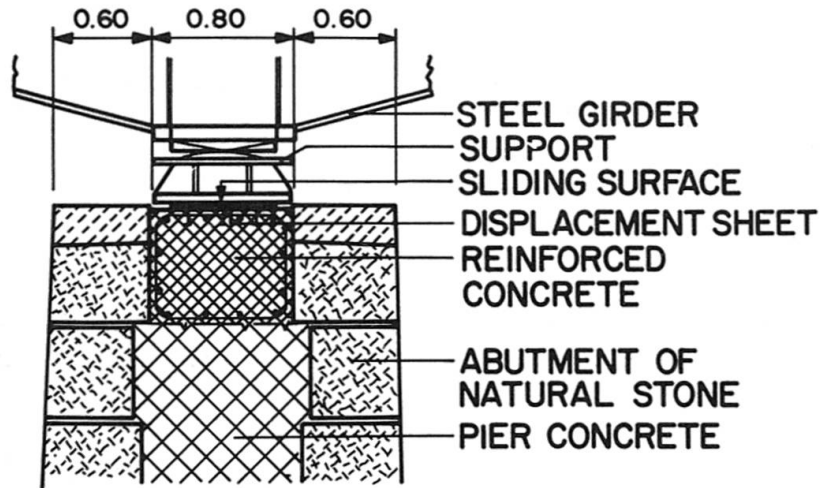

Fig. 4: Bridge support on the existing piers

- displacement procedure

Eight VSL-strand tension apparatus will pull the new bridge on cables into the planned position. The existing bridge will be pushed ahead by the new one on to the displacement track in up-stream direction. A special structure between the second and third main girder of the new bridge takes the movement force. The cables are mounted on to anchorage points at the displacement track "Lake". A practically closed power system is produced. Piles and kentledge are stressed only moderately by horizontal power.

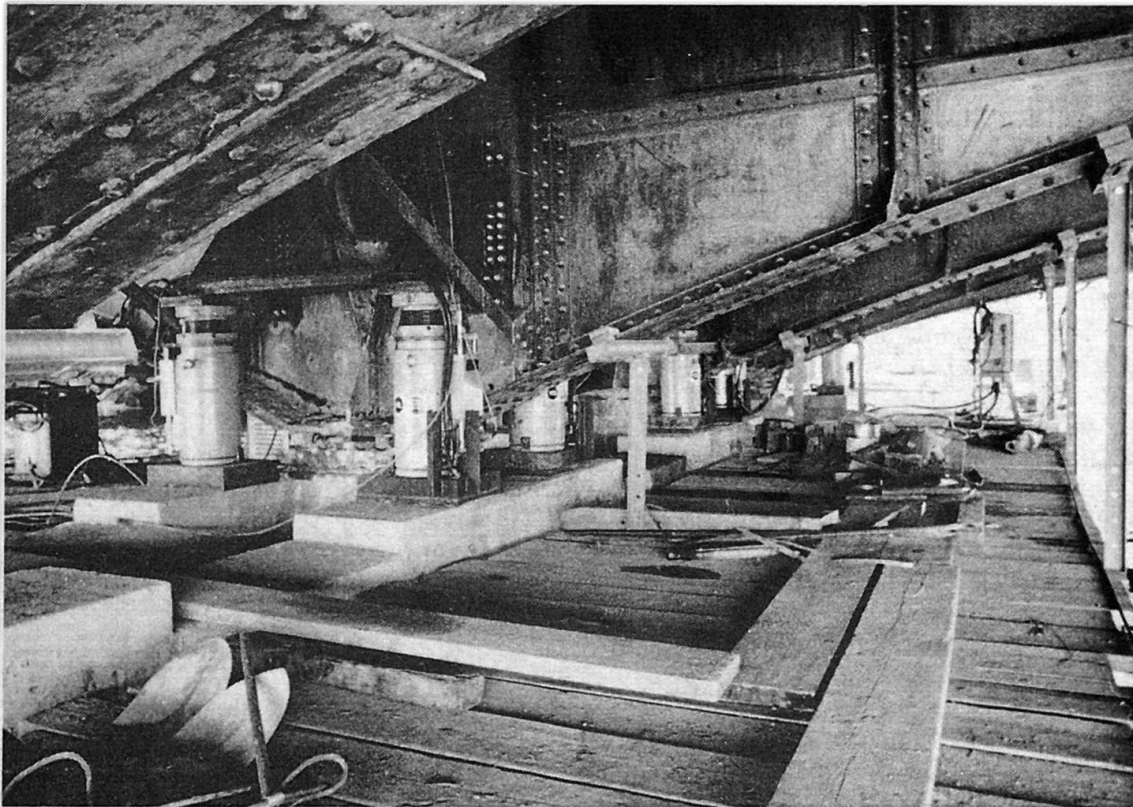

Photo 1: Exchange of the old supports with sliding supports, under traffic flow

The sliding supports are chromed on the underside. They glide on teflon coated neoprene cushions. This disposition allows a secure load-transfer if unevenness of the displacement track should arise.

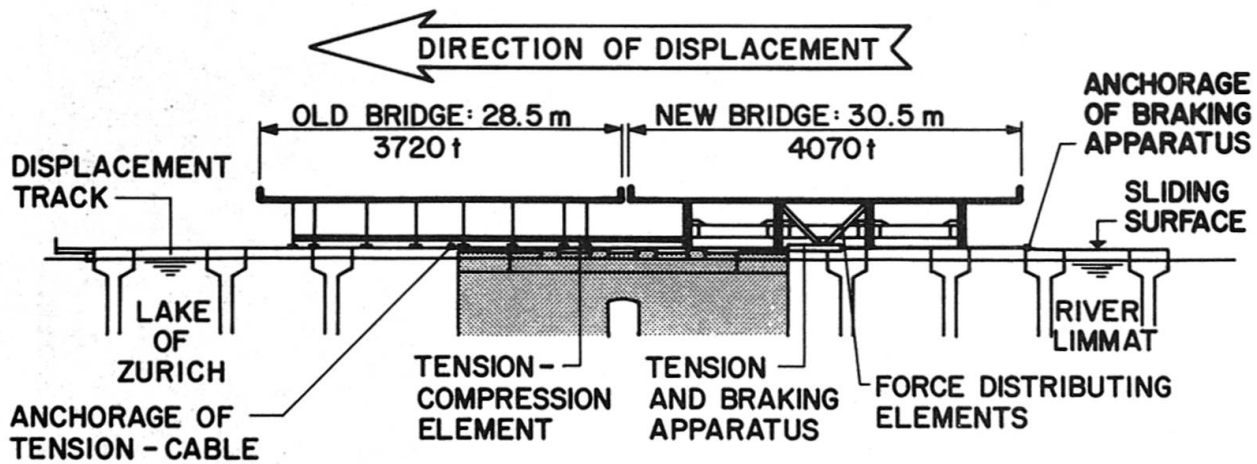

Fig. 5: Transverse section with displacement equipment

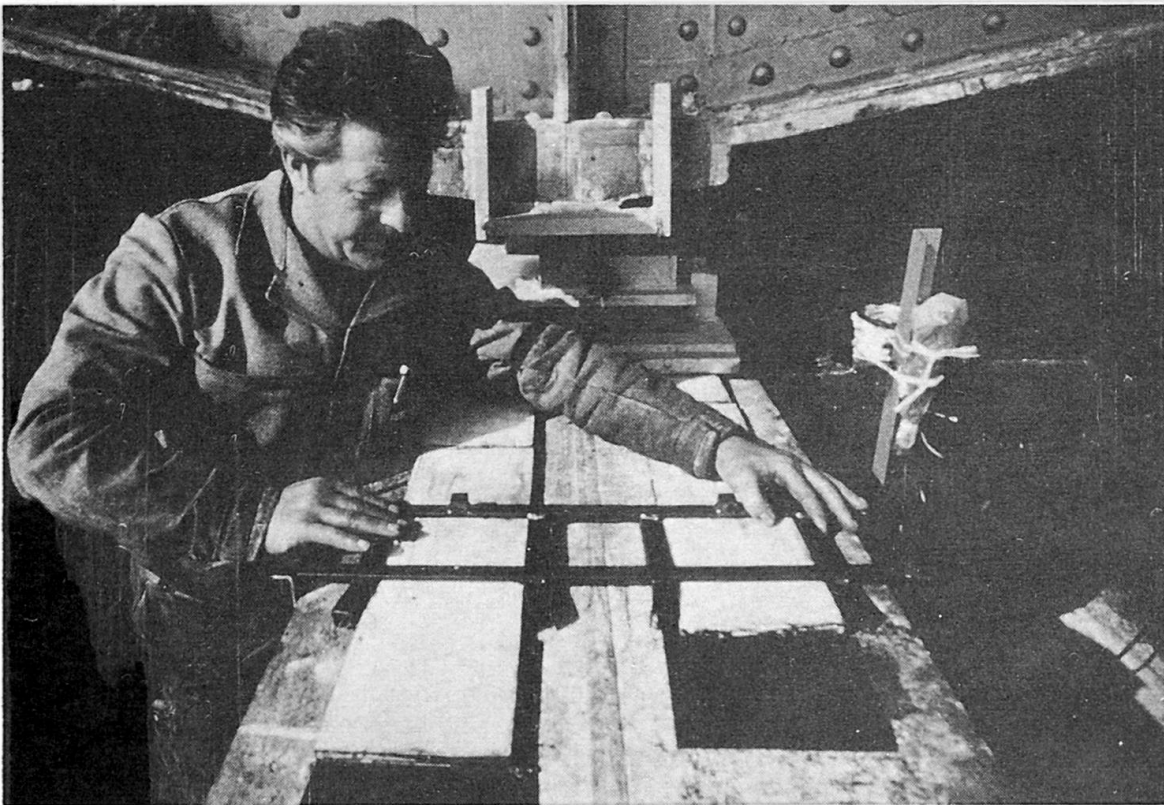

Photo 2: Placing the teflon-coated neoprene cushions

- bearing change of the new bridge.

Immediately after the displacement of the bridges, the lower sliding part of the slidetrack has to be removed and replaced by lining plates of the same thickness.

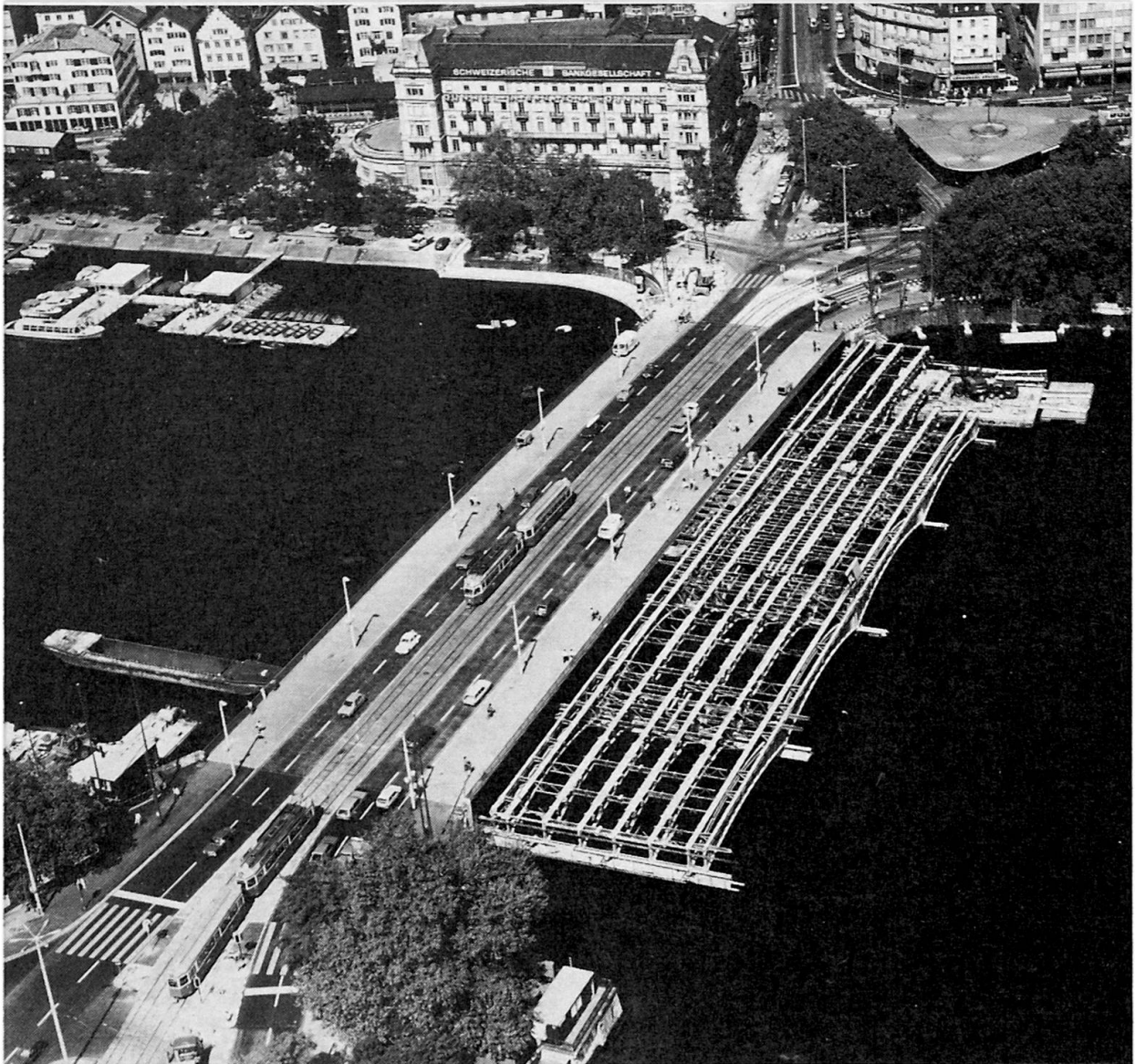

Photo 3: Demolition work on the old bridge (right) after the displacement

9. SURVEY AND SUPERVISION

Whilst the construction and the displacement was going ahead, extensive measuring was done. Special requirements were made for the measuring of the displacement as it had to be done for many uninterrupted hours and with exact and most precise instruments and manpower. The measuring of the height and position of the displacement track and piles was done by a modern electronic theodolite system. Also on both bridges two groups were working with a precise levelling instrument in order to be able to control the deformation of the bridge. Visual controls of the displacement also were made and a telephone and alarm system completed the extensive safety system whilst the construction was taking place and afterwards during the displacement. This was necessary as the site was exposed and many spectators were present.

10. RECONSTRUCTION OF THE BELLEVUE CAVERN

The Bellevue cavern was in a very poor condition:

- the woodpile foundations could be re-used. The pileheads had to be renewed.
- reinforcement of the steel girder grille. The steel girder grille had to be strengthened. The main girder was in very bad shape.

The concrete slab was also in poor shape due to the de-icing salt and had to be insulated and sealed.

SOURCES

For the basic information I thank

Prof. Richard Heierli, Dipl. Ing. ETH, Chief of the Construction Engineering Office of the City of Zurich, and

Oskar Skrotzky, Dipl. Ing. ETH, Director of Fietz Leuthold/Zurich..
(joint venture Fietz Leuthold/Schneider for the new Quaibrücke).