

Zeitschrift: IABSE proceedings = Mémoires AIPC = IVBH Abhandlungen
Band: 1 (1977)
Heft: P-9: A rational analysis of plates with eccentric stiffeners

Artikel: A rational analysis of plates with eccentric stiffeners
Autor: Hovichitr, Intarachai / Nishino, Fumio / Karasudhi, Pisdhi
DOI: <https://doi.org/10.5169/seals-32461>

Nutzungsbedingungen

Die ETH-Bibliothek ist die Anbieterin der digitalisierten Zeitschriften. Sie besitzt keine Urheberrechte an den Zeitschriften und ist nicht verantwortlich für deren Inhalte. Die Rechte liegen in der Regel bei den Herausgebern beziehungsweise den externen Rechteinhabern. [Siehe Rechtliche Hinweise.](#)

Conditions d'utilisation

L'ETH Library est le fournisseur des revues numérisées. Elle ne détient aucun droit d'auteur sur les revues et n'est pas responsable de leur contenu. En règle générale, les droits sont détenus par les éditeurs ou les détenteurs de droits externes. [Voir Informations légales.](#)

Terms of use

The ETH Library is the provider of the digitised journals. It does not own any copyrights to the journals and is not responsible for their content. The rights usually lie with the publishers or the external rights holders. [See Legal notice.](#)

Download PDF: 16.03.2025

ETH-Bibliothek Zürich, E-Periodica, <https://www.e-periodica.ch>

A Rational Analysis of Plates with Eccentric Stiffeners

Analyse rationnelle de plaques avec des raidisseurs excentrés

Berechnung von Platten mit exzentrischen Steifen

Intarachai HOVICHITR

Research Associate
Asian Institute of Technology
Bangkok, Thailand

Fumio NISHINO

Associate Professor
Department of Civil Engineering
University of Tokyo
Tokyo, Japan

Pisidhi KARASUDHI

Associate Professor
Division of Structural Engineering
Asian Institute of Technology
Bangkok, Thailand

Seng-Lip LEE

Professor and Head
Department of Civil Engineering
University of Singapore
Singapore

SUMMARY

A rational analysis of a rectangular plate with eccentric stiffeners is carried out by a variational principle, leading to a governing differential equation of order ten and a set of natural boundary conditions. Neglecting the lateral bending and the bimoments of the ribs yields an approximate theory with an eighth order differential equation. To make this study more practical, a fourth order governing equation is derived. The results by these two approximate theories for two simple cases, are compared with the results by the original ten order theory.

RÉSUMÉ

L'analyse rationnelle d'une plaque rectangulaire avec des raidisseurs excentrés est effectuée au moyen du calcul des variations, conduisant à une équation différentielle du 10^e ordre et à un certain nombre de conditions aux limites naturelles.

Le fait de négliger la flexion latérale et les bimoments des nervures permet de développer une théorie approchée avec une équation différentielle du 8^e ordre. Une équation différentielle du 4^e ordre est établie afin de rendre cette étude plus pratique. Les applications de ces deux théories approchées dans deux cas simples sont comparées aux résultats de la théorie générale du 10^e ordre.

ZUSAMMENFASSUNG

Anhand eines Variationsprinzipes wird zur Berechnung einer Rechteckplatte mit exzentrischen Steifen eine Differentialgleichung 2. Ordnung mit entsprechenden natürlichen Randbedingungen gewonnen. Durch Vernachlässigung der Querbiegung und der Wölbmomente der Rippen kommt man zu einer Näherungstheorie mit einer Differentialgleichung 8. Ordnung. Um die praktische Anwendung zu vereinfachen, wird eine Differentialgleichung 4. Ordnung abgeleitet. Die Ergebnisse dieser Zwei Näherungsmethoden für zwei einfache Fälle werden mit denjenigen der ursprünglichen 10. Ordnung verglichen.



1. INTRODUCTION

The analysis of an eccentrically stiffened plate by an orthotropic plate theory was first developed by HUBER [1]. In his approach, the top slab and the stiffeners are "smeared" into an orthotropic plate of equivalent bending and torsional rigidities. The bending rigidity was later reevaluated by BARES and MASSONNET [2] taking into account of the full interaction between the slab and the stiffening grid system. An analysis in which the effect of Poisson's ratio was considered for the slab and for the actual contact area between the intersecting ribs was developed by CUSENS, ZEIDAN and PAMA [3]. NISHINO, PAMA and LEE [4] considered the interaction between the slab and the grid system in the determination of these rigidities. Various attempts also made to develop a more exact theory for this problem lead to governing differential equations with higher orders than Huber's equation, e.g., PFLÜGER [5], MASSONNET [6], and CLIFTON, CHANG and AU [7]. However, the torsional rigidity proposed by all these investigators does not agree well with the experimental results.

The principal objective of this study is to establish a rigorous and feasible approach to the problem of the design of plates with eccentric stiffeners. By means of a variational principle, natural boundary conditions and three coupled differential equations are obtained involving one parameter, whose value is assumed in such a way that the anticlastic solution by this theory agrees closely with the experimental results. These governing differential equations are reduced in order from ten to eight by neglecting the lateral bending and the bimoments in the ribs. Furthermore, a single governing equation of Huber's type is obtained. The solutions by these two approximate theories are compared with the original tenth order theory, for the cases of a plate under a cylindrical bending and a simply supported plate subjected to a uniform load.

2. PROBLEM FORMULATION BY VARIATIONAL PRINCIPLE

2.1 Sign Convention and Basic Assumptions

Significant dimensions of a typical element of a plate with eccentric stiffeners are shown in Fig. 1. The positive directions of the corresponding displacement components are also indicated. For stresses, the sign convention as adopted by TIMOSHENKO and GOODIER [8] is used. The pertinent assumptions in this regard are as follows: all displacements are small; the slab and ribs are made of thin plates; points initially lying on the normal to the middle surface remain on the

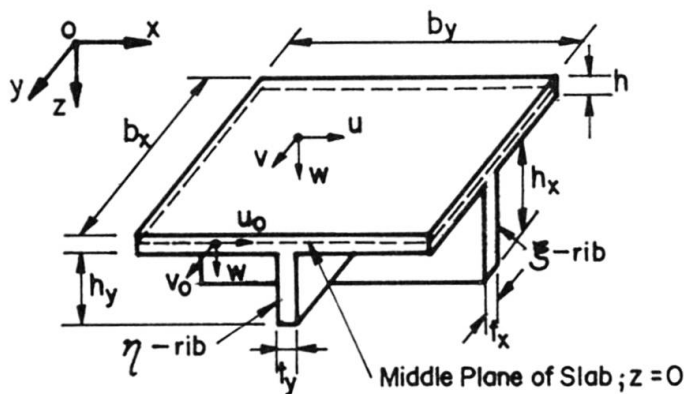

Fig. 1 Typical Element of Plate with Eccentric Stiffeners

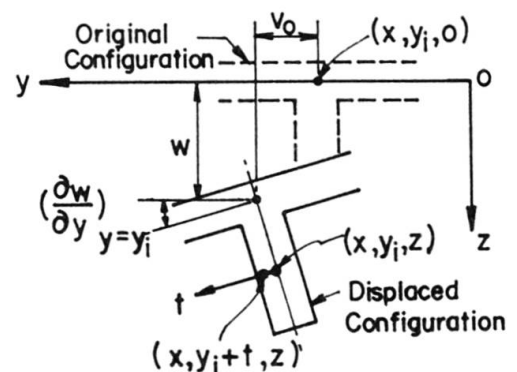

Fig. 2 Original and Displaced Configurations of ξ -Rib, at $y = y_i$

normal after deformation; cross sections of the ribs do not distort; shear strains along the middle plane and also across the thickness of the thin ribs are small and can be neglected.

2.2 Strain-Displacement Relations

According to the above assumptions, displacements and strains can be written as follows; for the top slab,

$$w(x,y,z) = w(x,y) \quad (1a)$$

$$u(x,y,z) = u_o(x,y) - z \frac{\partial w}{\partial x}(x,y), \quad v(x,y,z) = v_o(x,y) - z \frac{\partial w}{\partial y}(x,y) \quad (1b,c)$$

and

$$\epsilon_x = \frac{\partial u_o}{\partial x} - z \frac{\partial^2 w}{\partial x^2}, \quad \epsilon_y = \frac{\partial v_o}{\partial y} - z \frac{\partial^2 w}{\partial y^2}, \quad \gamma_{xy} = \gamma_{yx} = \frac{\partial u_o}{\partial y} + \frac{\partial v_o}{\partial x} - 2z \frac{\partial^2 w}{\partial x \partial y} \quad (2a-c)$$

$$\epsilon_z = 0, \quad \gamma_{yz} = \gamma_{zy} = 0, \quad \gamma_{zx} = \gamma_{xz} = 0 \quad (2d-f)$$

for a ξ -rib, spanning in x-direction, at $y = y_i$,

$$w(x,y_i+t,z) = w(x,y_i) + t \left(\frac{\partial w}{\partial y} \right)_{y=y_i}, \quad v(x,y_i+t,z) = v_o(x,y_i) - z \left(\frac{\partial w}{\partial y} \right)_{y=y_i} \quad (3a,b)$$

$$u(x,y_i+t,z) = u_o(x,y_i) - z \left(\frac{\partial w}{\partial x} \right)_{y=y_i} + \left[z \left(\frac{\partial^2 w}{\partial x \partial y} \right)_{y=y_i} - \frac{\partial v_o}{\partial x}(x,y_i) \right] t \quad (3c)$$

and

$$\epsilon_x = \frac{\partial u_o}{\partial x}(x,y_i) - z \left(\frac{\partial^2 w}{\partial x^2} \right)_{y=y_i} + \left[z \left(\frac{\partial^2 w}{\partial x^2 \partial y} \right)_{y=y_i} - \frac{\partial^2 v_o}{\partial x^2}(x,y_i) \right] t \quad (4a)$$

$$\gamma_{xz} = \gamma_{zx} = 2t \left(\frac{\partial^2 w}{\partial x \partial y} \right)_{y=y_i}, \quad \epsilon_t = 0, \quad \epsilon_z = 0, \quad \gamma_{xt} = \gamma_{tx} = 0, \quad \gamma_{tz} = \gamma_{zt} = 0 \quad (4b-f)$$

in which t is an arbitrary coordinate axis normal to the middle plane of the ξ -rib as shown in Fig. 2. Similarly for an η -rib, spanning in y-direction, at $x = x_j$,

$$w(x_j+t',y,z) = w(x_j,y) + t' \left(\frac{\partial w}{\partial x} \right)_{x=x_j}, \quad u(x_j+t',y,z) = u_o(x_j,y) - z \left(\frac{\partial w}{\partial x} \right)_{x=x_j} \quad (5a,b)$$

$$v(x_j+t',y,z) = v_o(x_j,y) - z \left(\frac{\partial w}{\partial y} \right)_{x=x_j} + \left[z \left(\frac{\partial^2 w}{\partial x \partial y} \right)_{x=x_j} - \frac{\partial u_o}{\partial y}(x_j,y) \right] t' \quad (5c)$$

and

$$\epsilon_y = \frac{\partial v_o}{\partial y}(x_j,y) - z \left(\frac{\partial^2 w}{\partial y^2} \right)_{x=x_j} + \left[z \left(\frac{\partial^2 w}{\partial x \partial y^2} \right)_{x=x_j} - \frac{\partial^2 u_o}{\partial y^2}(x_j,y) \right] t' \quad (6a)$$

$$\gamma_{yz} = \gamma_{zy} = 2t' \left(\frac{\partial^2 w}{\partial x \partial y} \right)_{x=x_j}, \quad \epsilon_{t'} = 0, \quad \epsilon_z = 0, \quad \gamma_{yt'} = \gamma_{t'y} = 0, \quad \gamma_{zt'} = \gamma_{t'z} = 0 \quad (6b-f)$$

where t' is an arbitrary coordinate axis normal to the middle plane of the η -rib. At the intersection of the ξ -rib at $y = y_i$ and the η -rib at $x = x_j$, the strain-displacement relations are assumed to take the same forms as those for the ribs, excepting that γ_{xy} and γ_{yx} are assumed in the form similar to that of the slab, i.e.,

$$\gamma_{xy} = \gamma_{yx} = \left(\frac{\partial u_o}{\partial y} + \frac{\partial v_o}{\partial x} - 2\bar{h} \frac{\partial^2 w}{\partial x \partial y} \right)_{x=x_j, y=y_i} \quad (7)$$



where $x_j - t_y/2 \leq x \leq x_j + t_y/2$, $y_i - t_x/2 \leq y \leq y_i + t_x/2$ and $h/2 \leq z \leq h/2 + h_y$, assuming that $h_y \leq h_x$. The term \bar{h} will be determined in such a way that the pure torsional rigidity obtained from this formulation agrees reasonably well with the experimental results.

2.3 Equilibrium Equations and Boundary Conditions

The virtual work principle can be written as

$$W_i = W_e \quad (8)$$

where W_i and W_e are the internal and external virtual work, respectively, and can be expressed in the forms

$$W_i = \iiint_V \left[\sigma_x \delta \epsilon_x + \sigma_y \delta \epsilon_y + \sigma_z \delta \epsilon_z + \tau_{xy} \delta \gamma_{xy} + \tau_{yz} \delta \gamma_{yz} + \tau_{zx} \delta \gamma_{zx} \right] dV \quad (9)$$

$$W_e = \int_A \int q(x,y) \delta w dA + \left[\int_{b_1}^{b_2} \int_z (\bar{\sigma}_x \delta u + \bar{\tau}_{xy} \delta v + \bar{\tau}_{xz} \delta w) dz dy \right]_{x=a_1}^{x=a_2} + \left[\int_{a_1}^{a_2} \int_z (\bar{\sigma}_y \delta v + \bar{\tau}_{yx} \delta u + \bar{\tau}_{yz} \delta w) dz dx \right]_{y=b_1}^{y=b_2} \quad (10)$$

where $q(x,y)$ is the applied transverse load, a bar ($\bar{\quad}$) denotes a boundary traction, $x = a_1, a_2$ and $y = b_1, b_2$ are the four edges of the plate.

Substituting Eqs. (9) and (10) into Eq. (8), in views of Eqs. (1) to (7), and applying Green's formula lead to the equilibrium equations, for an eccentrically stiffened plate with identical and equally spaced ribs in each direction, as follows

$$\frac{\partial N_x}{\partial x} + \frac{\partial N_{yx}}{\partial y} = 0, \quad \frac{\partial N_{xy}}{\partial x} + \frac{\partial N_y}{\partial y} = 0 \quad (11a,b)$$

$$\frac{\partial^2 M_x}{\partial x^2} + \frac{\partial^2 M_{xy}}{\partial x \partial y} + \frac{\partial^2 M_{yx}}{\partial x \partial y} + \frac{\partial^2 M_y}{\partial y^2} + q(x,y) = 0 \quad (11c)$$

and the natural boundary conditions are, along the edges $x = a_1$ and $x = a_2$,

$$N_x = \bar{N}_x, \quad \text{or} \quad u_o = \text{constant} \quad (12a)$$

$$N_{xy} = \bar{N}_{xy}, \quad \text{or} \quad v_o = \text{constant} \quad (12b)$$

$$V_x = \bar{Q}_x + \frac{\partial}{\partial y} (\bar{M}_{xy} - \bar{M}_{xz}, \xi) \quad \text{or} \quad w = \text{constant} \quad (12c)$$

$$M_x^* = \bar{M}_x + \frac{\partial \bar{M}_{\omega, \xi}}{\partial y} \quad \text{or} \quad \frac{\partial w}{\partial x} = \text{constant} \quad (12d)$$

$$M_{z, \xi} = \bar{M}_{z, \xi} \quad \text{or} \quad \frac{\partial v_o}{\partial x} = \text{constant} \quad (12e)$$

along the edges $y = b_1$ and $y = b_2$,

$$N_{yx} = \bar{N}_{yx}, \quad \text{or} \quad u_o = \text{constant} \quad (13a)$$

$$N_y = \bar{N}_y, \quad \text{or} \quad v_o = \text{constant} \quad (13b)$$

$$V_y = \bar{Q}_y + \frac{\partial}{\partial x} (\bar{M}_{yx} - \bar{M}_{yz}, \eta) \quad \text{or} \quad w = \text{constant} \quad (13c)$$



$$M_y^* = \bar{M}_y + \frac{\partial \bar{M}_{\omega, \eta}}{\partial x}, \quad \text{or} \quad \frac{\partial w}{\partial y} = \text{constant} \quad (13d)$$

$$M_{z, \eta} = \bar{M}_{z, \eta}, \quad \text{or} \quad \frac{\partial u_o}{\partial y} = \text{constant} \quad (13e)$$

and, at the corners,

$$R = \bar{M}_{xy} + \bar{M}_{yx} - \bar{M}_{xz, \xi} - \bar{M}_{yz, \eta}, \quad \text{or} \quad w = \text{constant} \quad (14a)$$

$$\hat{M}_x = \bar{M}_{\omega, \xi}, \quad \text{or} \quad \frac{\partial w}{\partial x} = \text{constant} \quad (14b)$$

$$\hat{M}_y = \bar{M}_{\omega, \eta}, \quad \text{or} \quad \frac{\partial w}{\partial y} = \text{constant} \quad (14c)$$

where

$$N_x = N_{x,p} + N_{x,\xi}, \quad N_{xy} = N_{xy,p} + N_{xy,I} + \frac{\partial M_{z,\xi}}{\partial x} \quad (15a,b)$$

$$M_x = M_{x,p} + M_{x,\xi}, \quad M_{xy} = M_{xy,p} + M_{xy,I} - 2M_{xz,\xi} + \frac{\partial M_{\omega,\xi}}{\partial x} \quad (15c,d)$$

$$Q_x = \frac{\partial M_x}{\partial x} + \frac{\partial M_{yx}}{\partial y}, \quad V_x = Q_x + \frac{\partial M_{xy}}{\partial y}, \quad R = -M_{xy} - M_{yx} \quad (15e-g)$$

$$M_x^* = M_x + \frac{\partial M_{\omega,\xi}}{\partial y}, \quad \hat{M}_x = M_{\omega,\xi} \quad (15h,i)$$

and

$$N_{x,p} = \int_{-\frac{h}{2}}^{\frac{h}{2}} \sigma_x dz, \quad N_{x,\xi} = \frac{1}{b_x} \int_{A_x} \sigma_x dA, \quad N_{xy,p} = \int_{-\frac{h}{2}}^{\frac{h}{2}} \tau_{xy} dz \quad (16a-c)$$

$$N_{xy,I} = \frac{1}{b_x b_y} \int_V \tau_{xy} dV, \quad M_{x,p} = \int_{-\frac{h}{2}}^{\frac{h}{2}} \sigma_x z dz, \quad M_{x,\xi} = \frac{1}{b_x} \int_{A_x} \sigma_x z dA \quad (16d-f)$$

$$M_{xy,p} = \int_{-\frac{h}{2}}^{\frac{h}{2}} \tau_{xy} z dz, \quad M_{xy,I} = \frac{1}{b_x b_y} \int_V \tau_{xy} \bar{h} dV, \quad M_{xz,\xi} = \frac{1}{b_x} \int_{A_x} \tau_{xz} t dA \quad (16g-i)$$

$$M_{z,\xi} = \frac{1}{b_x} \int_{A_x} \sigma_x t dA, \quad M_{\omega,\xi} = \frac{1}{b_x} \int_{A_x} \sigma_x z t dA \quad (16j,k)$$

In Eqs. (15) and (16) are stress resultants in x-direction. Those in y-direction can be written in similar forms. It is of interest to note the presence of $M_{\omega,\xi}$ and $M_{\omega,\eta}$, which are bimoment stress resultants. This induces the supplemented moment stress resultants M_x^* and M_y^* , and the corner moments \hat{M}_x and \hat{M}_y ; which are analogous to the induction of the supplemented shear stress resultants and the corner forces by M_{xy} and M_{yx} .

2.4 Stress-Strain Relations

The stress-strain relations are, for the slab,

$$\sigma_x = \frac{E}{1-\nu^2} (\epsilon_x + \nu \epsilon_y), \quad \sigma_y = \frac{E}{1-\nu^2} (\epsilon_y + \nu \epsilon_x), \quad \tau_{xy} = \frac{E}{2(1+\nu)} \gamma_{xy} \quad (17a-c)$$

where ν and E are the Poisson's ratio and Young's modulus of the slab; for ξ -ribs,



$$\sigma_x = E_\xi \epsilon_x, \quad \tau_{xz} = G_\xi \gamma_{xz} \quad (18a,b)$$

and, for η -ribs,

$$\sigma_y = E_\eta \epsilon_y, \quad \tau_{yz} = G_\eta \gamma_{yz} \quad (19a,b)$$

where E_ξ and G_ξ are the Young's modulus and the modulus of rigidity of ξ -ribs, while E_η and G_η are those of η -ribs, respectively. In addition, the stress-strain relations for rib intersections are

$$\sigma_x = E_\xi \epsilon_x, \quad \sigma_y = E_\eta \epsilon_y, \quad \tau_{xy} = G_I \gamma_{xy} \quad (20a-c)$$

in which G_I is the shear modulus of the intersections.

2.5 Stress Resultant - Displacement Relations

Substituting the stress-strain relations above into Eqs. (15), in view of Eqs. (16), leads to the stress resultants in x -direction as the followings.

$$N_x = (B+B_x) \frac{\partial u_o}{\partial x} + \nu B \frac{\partial v_o}{\partial y} - C_x \frac{\partial^2 w}{\partial x^2} \quad (21a)$$

$$N_{xy} = \left[\frac{(1-\nu)}{2} B + B' \right] \left(\frac{\partial u_o}{\partial y} + \frac{\partial v_o}{\partial x} \right) - 2C' \frac{\partial^2 w}{\partial x \partial y} - B_x^* \frac{\partial^3 v_o}{\partial x^3} + C_x^* \frac{\partial^4 w}{\partial x^3 \partial y} \quad (21b)$$

$$M_x = -(D+D_x) \frac{\partial^2 w}{\partial x^2} - \nu D \frac{\partial^2 w}{\partial y^2} + C_x \frac{\partial u_o}{\partial x} \quad (21c)$$

$$M_{xy} = -[(1-\nu)D + H_x + 2D'] \frac{\partial^2 w}{\partial x \partial y} + C' \left(\frac{\partial u_o}{\partial y} + \frac{\partial v_o}{\partial x} \right) - C_x^* \frac{\partial^3 v_o}{\partial x^3} + D_x^* \frac{\partial^4 w}{\partial x^3 \partial y} \quad (21d)$$

$$Q_x = -(D+D_x) \frac{\partial^3 w}{\partial x^3} - (D+H_y + 2D') \frac{\partial^3 w}{\partial x \partial y^2} + C_x \frac{\partial^2 u_o}{\partial x^2} + C' \left(\frac{\partial^2 u_o}{\partial y^2} + \frac{\partial^2 v_o}{\partial x \partial y} \right) - C_y^* \frac{\partial^4 u_o}{\partial y^4} + D_y^* \frac{\partial^5 w}{\partial x \partial y^4} \quad (21e)$$

$$M_{z,\xi} = C_x^* \frac{\partial^3 w}{\partial x^2 \partial y} - B_x^* \frac{\partial^2 v_o}{\partial x^2}, \quad M_{\omega,\xi} = D_x^* \frac{\partial^3 w}{\partial x^2 \partial y} - C_x^* \frac{\partial^2 v_o}{\partial x^2} \quad (21f,g)$$

in which

$$B = Eh/(1-\nu^2), \quad D = Eh^3/12(1-\nu^2), \quad B_x = E_\xi A_\xi \quad (22a-c)$$

$$C_x = E_\xi S_{y,\xi}, \quad D_x = E_\xi I_{y,\xi}, \quad H_x = t_x^2 A_\xi G_\xi / 3 \quad (22d-f)$$

$$B_x^* = t_x^2 B_x / 12, \quad C_x^* = t_x^2 C_x / 12, \quad D_x^* = t_x^2 D_x / 12 \quad (22g-i)$$

$$B' = \frac{t_x t_y}{b_x b_y} h_y G_I, \quad C' = B' \bar{h}, \quad D' = C' \bar{h} \quad (22j-l)$$

and

$$A_\xi = \frac{1}{b_x} \int_{A_x} \int dA, \quad S_{y,\xi} = \frac{1}{b_x} \int_{A_x} \int z dA, \quad I_{y,\xi} = \frac{1}{b_x} \int_{A_x} \int z^2 dA \quad (23a-c)$$

The stress resultants in y -direction, which can be written in similar forms, are omitted in this paper for the sake of brevity.

2.6 Governing Differential Equations

Substituting the stress resultant-displacement relations above into the equilibrium equations yields the governing differential equations of the form

$$(B+B_x) \frac{\partial^2 u_0}{\partial x^2} + B_1 \frac{\partial^2 u_0}{\partial y^2} + B_2 \frac{\partial^2 v_0}{\partial x \partial y} - C_x \frac{\partial^3 w}{\partial x^3} - 2C'_x \frac{\partial^3 w}{\partial x \partial y^2} - B_y^* \frac{\partial^4 u_0}{\partial y^4} + C_y^* \frac{\partial^5 w}{\partial x \partial y^4} = 0 \quad (24a)$$

$$(B+B_y) \frac{\partial^2 v_0}{\partial y^2} + B_1 \frac{\partial^2 v_0}{\partial x^2} + B_2 \frac{\partial^2 u_0}{\partial x \partial y} - C_y \frac{\partial^3 w}{\partial y^3} - 2C'_y \frac{\partial^3 w}{\partial x^2 \partial y} - B_x^* \frac{\partial^4 v_0}{\partial x^4} + C_x^* \frac{\partial^5 w}{\partial x^4 \partial y} = 0 \quad (24b)$$

$$(D+D_x) \frac{\partial^4 w}{\partial x^4} + (2D+H_x + H_y + 4D') \frac{\partial^4 w}{\partial x^2 \partial y^2} + (D+D_y) \frac{\partial^4 w}{\partial y^4} - C_x \frac{\partial^3 u_0}{\partial x^3} - C_y \frac{\partial^3 v_0}{\partial y^3} - 2C'_x \left(\frac{\partial^3 u_0}{\partial x \partial y^2} + \frac{\partial^3 v_0}{\partial x^2 \partial y} \right) + C_y^* \frac{\partial^5 u_0}{\partial x \partial y^4} + C_x^* \frac{\partial^5 v_0}{\partial x^4 \partial y} - D_x^* \frac{\partial^6 w}{\partial x^4 \partial y^2} - D_y^* \frac{\partial^6 w}{\partial x^2 \partial y^4} = q(x,y) \quad (24c)$$

where $B_1 = (1-\nu)B/2+B'$, $B_2 = (1+\nu)B/2+B'$. Note that there are ten boundary conditions in each direction, hence the above simultaneous governing equations can be, if required, reduced into a single partial differential equation of order ten with only one independent variable, i.e., u_0 or v_0 or w .

2.7 Determination of \bar{h}

Considering the case of the anticlastic bending shown in Fig. 3; the governing equations, Eqs. (24) for $q(x,y) = 0$, the conditions of zero stress resultants along the plate edges, the conditions of zero deflection at the three supported corners, and the condition $R(a,b) = P$ at the loaded corner are satisfied by taking the displacement functions in the form

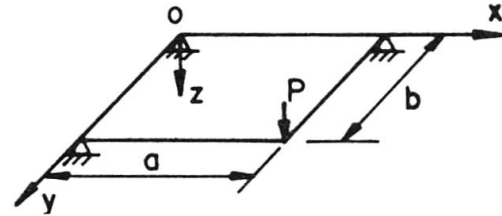

Fig. 3 Anticlastic Loading

$$u_0(x,y) = e \frac{\partial w}{\partial x}, \quad v_0(x,y) = e \frac{\partial w}{\partial y}, \quad w(x,y) = Pxy / (D_{xy} + D_{yx}) \quad (25a-c)$$

in which $e = C'/B_1$ and

$$D_{xy} = (1-\nu)D + H_x + 2D' - 2C'e, \quad D_{yx} = (1-\nu)D + H_y + 2D' - 2C'e \quad (26a,b)$$

In good agreement with the experimental results [9,10] as shown typically in Fig. 4, the value of the pure torsional rigidity, $D_{xy} + D_{yx}$, can be obtained with \bar{h} being proposed as

$$\bar{h} = \sqrt{h(h+h_y)}/2 \quad (27)$$

The results by CUSENS et al [3] and NISHINO et al [4] are also presented in Fig. 4 for comparison.

3. APPROXIMATE THEORIES

3.1 Approximate Theory with Eighth Order Differential Equation

The bimoments and the bending moments about z-axis of the ribs may be assumed negligible, and this assumption, in view of Eqs. (21f,g), can be carried out by setting $B_x^*, B_y^*, C_x^*, C_y^*, D_x^*$ and D_y^* to zero in all equations involved. Alternatively, this approximation can also be attained if the coefficients of t and t' in Eqs. (4a) and (6a) are dropped. Accordingly, the number of the natural boundary conditions, Eqs. (12) or (13), is reduced to eight, which indicates that the governing equations for this approximate theory can be represented by a single eighth order partial differential equation in terms of one independent variable.

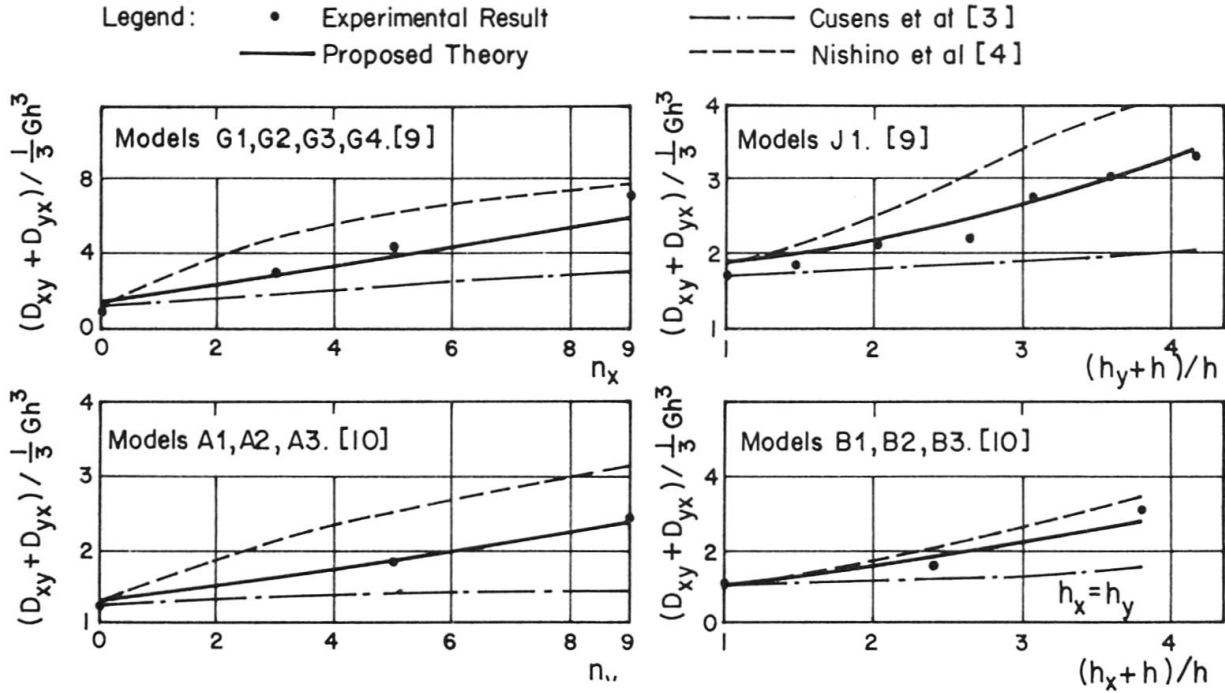

Fig. 4 Comparison of Pure Torsional Rigidities

3.2 Approximate Theory with Fourth Order Differential Equation

The fourth order differential equation of Huber's type [1], which is commonly adopted in practice, can be derived as follows: substituting the solution of the anticlastic bending, Eqs. (25), into Eqs. (21b,d) yields

$$N_{xy} = 0, \quad N_{yx} = 0, \quad M_{xy} = -D_{xy} \frac{\partial^2 w}{\partial x \partial y}, \quad M_{yx} = -D_{yx} \frac{\partial^2 w}{\partial y \partial x} \quad (28a-d)$$

where D_{xy} and D_{yx} are as defined by Eqs. (26). Equations (11), in views of Eqs. (21a,c) and Eqs. (28), become

$$(B+B_x) \frac{\partial^2 u_o}{\partial x^2} + \nu B \frac{\partial^2 v_o}{\partial x \partial y} - C_x \frac{\partial^3 w}{\partial x^3} = 0 \quad (29a)$$

$$(B+B_y) \frac{\partial^2 v_o}{\partial y^2} + \nu B \frac{\partial^2 u_o}{\partial x \partial y} - C_y \frac{\partial^3 w}{\partial y^3} = 0 \quad (29b)$$

$$(D+D_x) \frac{\partial^4 w}{\partial x^4} + (D_{xy} + D_{yx}) \frac{\partial^4 w}{\partial x^2 \partial y^2} + (D+D_y) \frac{\partial^4 w}{\partial y^4} - C_x \frac{\partial^3 u_o}{\partial x^3} - C_y \frac{\partial^3 v_o}{\partial y^3} = q(x,y) \quad (30)$$

Rearranging Eqs. (29) leads to

$$\frac{\partial^2 u_o}{\partial x^2} = \frac{C_x}{B+B_x} \frac{\partial^3 w}{\partial x^3} - \frac{B}{B+B_x} \nu \frac{\partial^2 v_o}{\partial x \partial y} \quad (31a)$$

$$\frac{\partial^2 v_o}{\partial y^2} = \frac{C_y}{B+B_y} \frac{\partial^3 w}{\partial y^3} - \frac{B}{B+B_y} \nu \frac{\partial^2 u_o}{\partial x \partial y} \quad (31b)$$

Assume, in the similar way as adopted by MASSONNET [6], that u_o and v_o appearing on the right hand side of Eqs. (31) take the forms

$$u_o = e_x \frac{\partial w}{\partial x}, \quad v_o = e_y \frac{\partial w}{\partial y} \quad (32a,b)$$

where $e_x = (h+h_x)/2$, $e_y = (h+h_y)/2$. In view of Eqs. (32), Eqs. (31) become

$$\frac{\partial^2 u_o}{\partial x^2} = e'_x \frac{\partial^3 w}{\partial x^3} - e''_x \frac{\partial^3 w}{\partial x \partial y^2}, \quad \frac{\partial^2 v_o}{\partial y^2} = e'_y \frac{\partial^3 w}{\partial y^3} - e''_y \frac{\partial^3 w}{\partial x^2 \partial y} \quad (33a,b)$$

in which

$$e'_x = \frac{C_x}{B+B_x}, \quad e'_y = \frac{C_y}{B+B_y} \quad (34a,b)$$

$$e''_x = \frac{\nu B}{B+B_x} e_y, \quad e''_y = \frac{\nu B}{B+B_y} e_x \quad (34c,d)$$

Substituting Eqs. (33) into Eq. (30) results in the fourth order governing equation of the form

$$D_{xx} \frac{\partial^4 w}{\partial x^4} + 2H \frac{\partial^4 w}{\partial x^2 \partial y^2} + D_{yy} \frac{\partial^4 w}{\partial y^4} = q(x,y) \quad (35)$$

Integrating Eq. (33a) with respect to x and substituting the result into Eq. (21c) yield

$$M_x = -D_{xx} \frac{\partial^2 w}{\partial x^2} - D_1 \frac{\partial^2 w}{\partial y^2} \quad (36a)$$

In fact, the above equation contains an arbitrary function of y , but it is set to zero to insure a vanishing M_x for the case of zero curvatures. Similarly, M_y can be obtained in the form

$$M_y = -D_{yy} \frac{\partial^2 w}{\partial y^2} - D_2 \frac{\partial^2 w}{\partial x^2} \quad (36b)$$

Substituting Eqs. (28c,d) and (36) into Eq. (15e) yields

$$Q_x = -D_{xx} \frac{\partial^3 w}{\partial x^3} - (D_{yx} + D_1) \frac{\partial^3 w}{\partial x \partial y^2}, \quad Q_y = -D_{yy} \frac{\partial^3 w}{\partial y^3} - (D_{xy} + D_2) \frac{\partial^3 w}{\partial x^2 \partial y} \quad (37a,b)$$

In Eqs. (35) to (37), there are following new notations;

$$D_{xx} = D + D_x - e'_x C_x, \quad D_{yy} = D + D_y - e'_y C_y \quad (38a,b)$$

$$D_1 = \nu D + e''_x C_x, \quad D_2 = \nu D + e''_y C_y \quad (38c,d)$$

$$D_{xy} = (1-\nu)D + H_x + 2D' - 2C'e, \quad D_{yx} = (1-\nu)D + H_y + 2D' - 2C'e \quad (38e,f)$$

$$2H = D_{xy} + D_{yx} + D_1 + D_2 = 2D + H_x + H_y + 4D' - 4C'e + e''_x C_x + e''_y C_y \quad (38g)$$

which denote the elastic rigidities of an eccentrically stiffened plate.

Typical numerical results based on these proposed rigidities are compared with the experimental results obtained by ZEIDAN [9] and VICTORIANO [10] as shown in Figs. 4 to 6.

4. COMPARISON OF RESULTS BY VARIOUS THEORIES

For the case of anticlastic bending, it can be seen that the two approximate theories yield essentially the same solution as the original theory of tenth order differential equation. In the two following sections, results by these three theories for two more simple problems are compared.

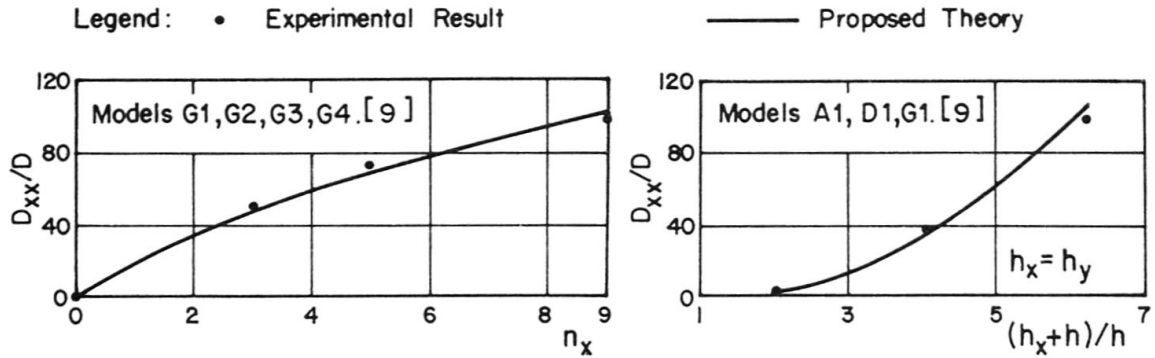

Fig. 5 Bending Rigidity D_{xx}

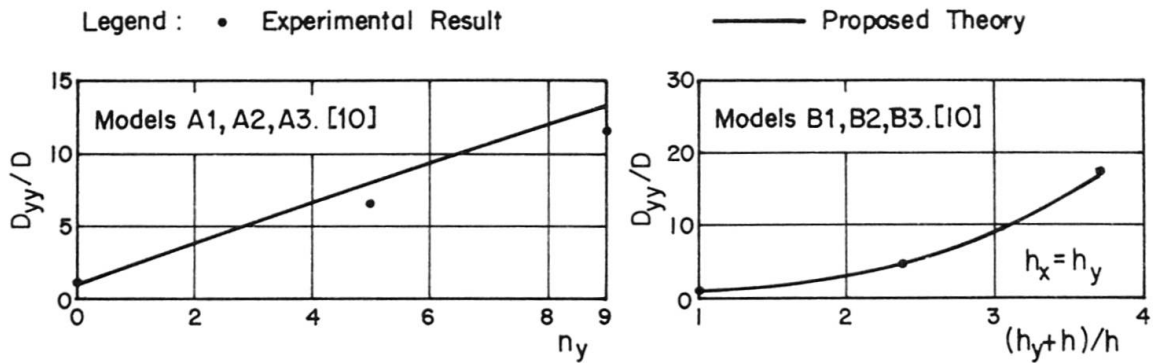

Fig. 6 Bending Rigidity D_{yy}

4.1 Cylindrical Bending

Considering the case of a plate which is infinitely long in y-direction, is subjected to a uniformly distributed load of intensity q_0 , and has two simply supported edges at $x = \pm a/2$; it is obvious that v_0 and all derivatives of u_0 and w with respect to y must vanish. It can be shown that, for the tenth order theory, the solution takes the form

$$u_0(x) = \frac{q_0 a^3 C_x}{D_{xx} (B+B_x)} \left[\left(\frac{x}{a}\right)^3 - \frac{3}{4} \left(\frac{x}{a}\right) \right], \quad w(x) = \frac{q_0 a^4}{24D_{xx}} \left[\left(\frac{x}{a}\right)^4 - \frac{3}{2} \left(\frac{x}{a}\right)^2 + \frac{5}{16} \right] \quad (39a, b)$$

The same solution of pertinent displacements and stress resultants can also be obtained by the other two approximate theories.

4.2 Simply Supported Plate

Consider the case of a rectangular plate simply supported along the edges $x = 0, x = a, y = 0$ and $y = b$; its boundary conditions are

$$v_0 = 0, \quad w = 0, \quad N_x = 0, \quad M_x^* = 0, \quad M_{z,\xi} = 0 \quad ; \quad \text{at } x=0, x=a \quad (40a-e)$$

$$u_0 = 0, \quad w = 0, \quad N_y = 0, \quad M_y^* = 0, \quad M_{z,\eta} = 0 \quad ; \quad \text{at } y=0, y=b \quad (40f-j)$$

To satisfy these boundary conditions, the displacement functions are taken in the form of double Fourier series as

$$u_0(x,y) = \sum_{n=1}^{\infty} \sum_{m=1}^{\infty} u_{mn} \cos(\alpha x) \sin(\beta y), \quad v_0(x,y) = \sum_{n=1}^{\infty} \sum_{m=1}^{\infty} v_{mn} \sin(\alpha x) \cos(\beta y) \quad (41a, b)$$

$$w(x,y) = \sum_{n=1}^{\infty} \sum_{m=1}^{\infty} w_{mn} \sin(\alpha x) \sin(\beta y) \quad (41c)$$

where $\alpha = m\pi/a$, $\beta = n\pi/b$. The load function $q(x,y)$ can be expressed also in the form of a double Fourier series as

$$q(x,y) = \sum_{n=1}^{\infty} \sum_{m=1}^{\infty} q_{mn} \sin(\alpha x) \sin(\beta y) \quad (42)$$

where

$$q_{mn} = \frac{4}{ab} \int_0^b \int_0^a q(x,y) \sin(\alpha x) \sin(\beta y) dx dy \quad (43)$$

Substituting Eqs. (41) and (42) into Eqs. (24) yields, for each harmonic m and n ,

$$\begin{pmatrix} k_{11} & k_{12} & k_{13} \\ k_{12} & k_{22} & k_{23} \\ k_{13} & k_{23} & k_{33} \end{pmatrix} \begin{pmatrix} u_{mn} \\ v_{mn} \\ w_{mn} \end{pmatrix} = \begin{pmatrix} 0 \\ 0 \\ q_{mn} \end{pmatrix} \quad (44)$$

in which

$$k_{11} = (B+B_x) \alpha^2 + B_1 \beta^2 + B_y^* \beta^4, \quad k_{12} = B_2 \alpha \beta \quad (45a,b)$$

$$k_{13} = -(C_x \alpha^3 + 2C' \alpha \beta^2 + C_y^* \alpha \beta^4), \quad k_{22} = (B+B_y) \beta^2 + B_1 \alpha^2 + B_x^* \alpha^4 \quad (45c,d)$$

$$k_{23} = -(C_y \beta^3 + 2C' \alpha^2 \beta + C_x^* \alpha^4 \beta) \quad (45e)$$

$$k_{33} = (D+D_x) \alpha^4 + (2D+H_x+H_y+4D') \alpha^2 \beta^2 + (D+D_y) \beta^4 + D_x^* \alpha^4 \beta^2 + D_y^* \alpha^2 \beta^4 \quad (45f)$$

For the approximation with a single governing differential equation of fourth order, Eq. (35), the boundary conditions are

$$w = 0, \quad M_x = 0 \quad ; \quad \text{at } x = 0, x = a \quad (46a,b)$$

$$w = 0, \quad M_y = 0 \quad ; \quad \text{at } y = 0, y = b \quad (46c,d)$$

To satisfy these boundary conditions and Eq. (35), the solution can be taken in the form of Eq. (41c), and w_{mn} is obtained as

$$w_{mn} = \frac{q_{mn}}{\Delta_{mn}} \quad (47)$$

where

$$\Delta_{mn} = D_{xx} \alpha^4 + 2H \alpha^2 \beta^2 + D_{yy} \beta^4 \quad (48)$$

and q_{mn} is defined by Eq. (43). Accordingly, the stress resultants can be determined by means of Eqs. (28c,d), (36), (37) and (41c).

The typical numerical results from the proposed theories, for the case of uniformly distributed load $q(x,y) = q_0$, are presented in Fig. 7 from which the accuracy of the approximate theories can be recognized. In addition, the results obtained by CUSENS, ZEIDAN and PAMA [3], and NISHINO, PAMA and LEE [4] are also put in this figure for comparison.

5. DISCUSSIONS AND CONCLUSIONS

In this study, the governing equations and natural boundary conditions of a plate with eccentric stiffeners are obtained by a rational analysis by means of a variational principle. The contributions of the top slab, the stiffening ribs

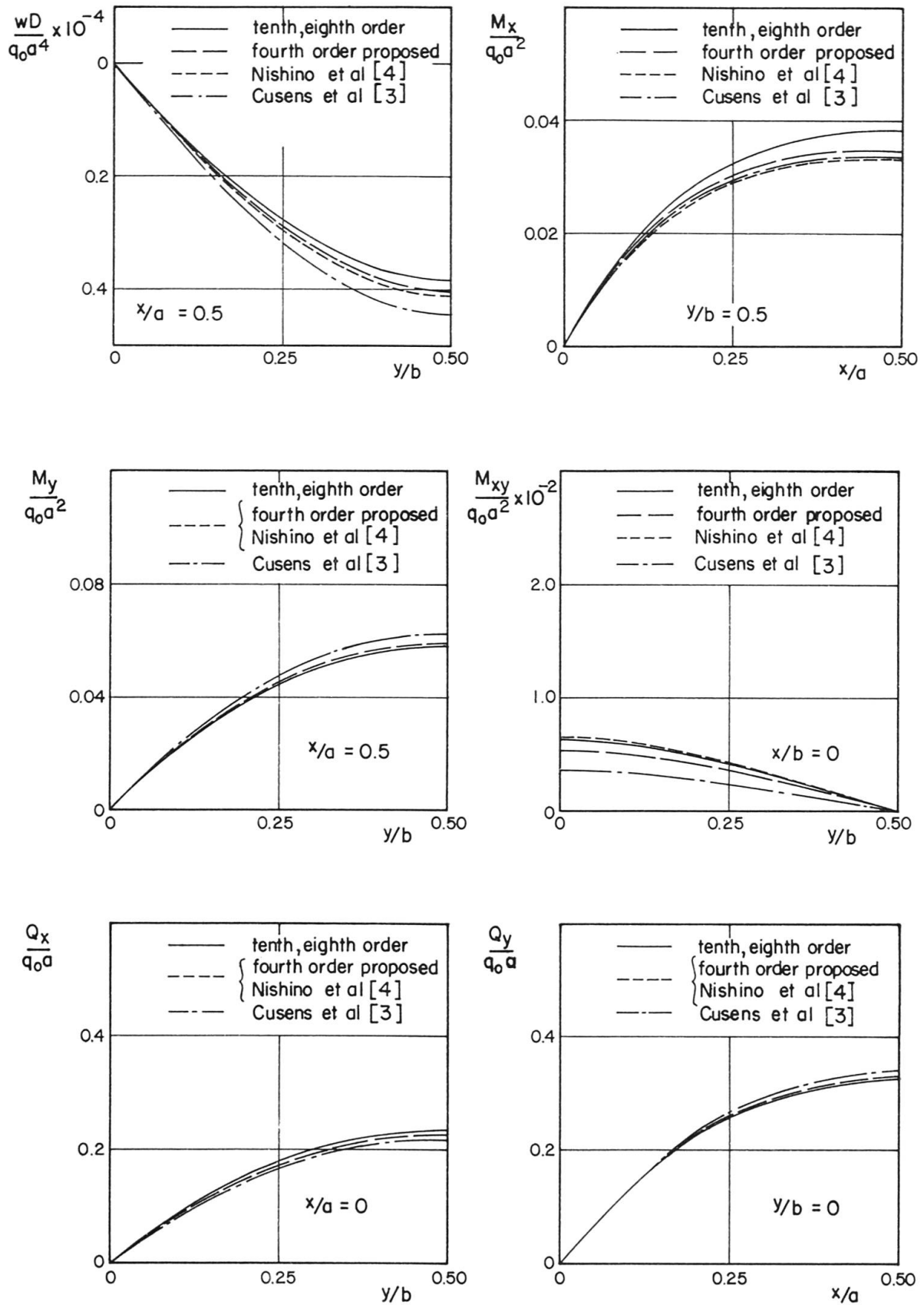

Fig. 7 Comparison of Deflection and Stress Resultants for Simply Supported Plate with Eccentric Stiffeners ($\nu = 0.15$, $n_x = 9$, $n_y = 12$, $b_x = b_y = 36''$, $t_x = t_y = 6''$, $h_x = h_y = 16''$, $h = 3''$)

and the intersection of these ribs to the overall behavior of the system can be identified clearly. For the intersection of the ribs, the shear strain-displacement relation is assumed in the form of Eq. (7) with \bar{h} being proposed as in Eq. (27). If disregarding the contributions by the in-plane displacements, the assumption adopted in these equations is equivalent to computing the torsional moments, due to the intersection of two orthogonal ribs at $x = x_j$ and $y = y_i$, by assuming that the shear stress τ_{xy} in the intersection is constant and equal to that in the top slab at $x = x_j$, $y = y_i$ and $z = h/2$.

Neglecting the lateral bending and the bimoments of the ribs appearing in the original tenth order theory leads to the approximate theory with an eighth order governing differential equation, which slightly differs from those obtained by other investigators [6,7]. This difference is due to the appropriate incorporation of the stiffness of the rib intersection in this study. The approximation with a fourth order governing differential equation of Huber's type [1] is derived in the similar way as adopted by MASSONNET [6] and in such a way that the solution for the case of the anticlastic bending is essentially identical to those by the tenth order and eighth order theories.

It can be shown analytically also that these theories give essentially the same solution for the case of a plate under a cylindrical bending. Furthermore, the numerical results by these theories for a simply supported plate subjected to a uniform load are compared in Fig. 7. Also included in these figures are the results by fourth order theories by CUSENS, ZEIDAN and PAMA [3] and NISHINO, PAMA and LEE [4]. It is obvious that the results by the eighth order theory agree best with the tenth order theory. Among the three fourth order theories compared, the proposed one agrees best with the tenth order theory for most slab sizes considered herein.

Lastly, it should be mentioned that this study is based in part on the dissertation of the senior author [11], in which the design charts of reinforced concrete slabs supported on rows of columns are also prepared by means of the proposed fourth order theory.

NOTATIONS

A_x, A_y	cross-sectional area of the ribs in x and y-directions, respectively	D	$Eh^3/12(1-\nu^2)$
a	length of plate in x-direction	D_x	as defined by Eq. (22e)
B	$Eh/(1-\nu^2)$	D_x^*, D'	as defined by Eqs. (22j, l)
B_x	as defined in Eq. (22a)	D_{xx}, D_{yy}	bending rigidities of an orthotropic plate, in x and y-directions, respectively
B_x^*, B'	as defined in Eqs. (22g, j)	D_{xy}, D_{yx}	pure torsional rigidities
B_1	$(1-\nu)B/2 + B'$	D_1, D_2	coupling rigidities in x and y-directions, respectively
B_2	$(1+\nu)B/2 + B'$	e	C'/B_1
b_x, b_y	spacings of the ribs in x and y-directions, respectively	$2H$	total torsional rigidity
C_x	as defined in Eq. (22d)	H_x	as defined in Eq. (22f)
C_x^*, C'	as defined in Eqs. (22h, k)	h	thickness of the top slab



h_x, h_y	heights of ribs in x and y-directions, respectively	n_x, n_y	number of ribs in x and y-directions, respectively
\bar{h}	$\sqrt{h(h+h_y)}/2$	p	subscript denoting top slab
I	subscript denoting intersection of two orthogonal ribs	R	corner force
M_x^*, M_y^*	supplemented bending moments in x and y-directions per unit width along y and x axes, respectively	t_x, t_y	thickness of the ribs in x and y-directions, respectively
$M_{z,\xi}$	bending moments about z axis of the ribs in x and y-directions per unit width along y and x axes, respectively	u_o, v_o	displacements of the middle plane of the top slab in x and y-directions, respectively
$M_{z,\eta}$	bending moments about z axis of the ribs in x and y-directions per unit width along y and x axes, respectively	V_{ij}	volume integral domain for rib intersection at point (x_j, y_i)
$M_{\omega,\xi}$	bimoments of the ribs in x and y-directions per unit width along y and x-directions, respectively	w	plate deflection in z-direction
$M_{\omega,\eta}$	bimoments of the ribs in x and y-directions per unit width along y and x-directions, respectively	ξ, η	ribs spanning in x and y-directions, respectively

REFERENCES

1. HUBER, M.T.: Die Theorie der Kreuzweise bewehrten Eisenbeton-platten nebst Anwendungen auf mehrere bautechnisch wichtige Aufgaben uber Rechteckige Platten. Bauingenieur, Vol. 4, 1923, p. 354-360, 392-395.
2. BARES, R., and MASSONNET, C.: Analysis of Beam Grids and Orthotropic Plates. Crosby Lockwood and Sons, London, 1968.
3. CUSENS, A.R., ZEIDAN, M.A., and PAMA, R.P.: Elastic Rigidities of Ribbed Plates. Building Science, Vol. 7, 1972, p. 23-32.
4. NISHINO, F., PAMA, R.P., and LEE, S.L.: Orthotropic Plates with Eccentric Stiffeners. Publications, IABSE, Vol. 34-II, 1974, p. 117-129.
5. PFLÜGER, A.: Zum Beulproblem der Anisotropen Rechteck Platte. Ingenieur Archiv, Vol. 19, 1947, p. 111-120.
6. MASSONNET, C.: Plaques et Coques Cylindriques Orthotropes a Nervures Dissymetriques. Publications, IABSE, Vol. 19, 1959, p. 201-230.
7. CLIFTON, R.J., CHANG, J.C., and AU, T.: Analysis of Orthotropic Plate Bridges. Proc. ASCE, J. Struct. Div., Vol. 89, No. ST5, 1963, p. 133-172.
8. TIMOSHENKO, S., and GOODIER, J.N.: Theory of Elasticity. McGraw-Hill Book Co., Inc., New York, 1951.
9. ZEIDAN, M.A.: Torsional and Flexural Rigidities of T-Beam Bridge Decks. Ph.D. Thesis, Univ. of Dundee, Scotland, 1970.
10. VICTORIANO, R.O.: An Experimental Investigation on the Rigidities of Ribbed Slabs. M.Eng. Thesis, Asian Inst. of Tech., Bangkok, Thailand, 1974.
11. HOVICHITR, I.: An Analysis of Waffle Slabs. D.Eng. Dissertation, Asian Inst. of Tech., Bangkok, Thailand, 1977.