

**Zeitschrift:** IABSE proceedings = Mémoires AIPC = IVBH Abhandlungen  
**Band:** 3 (1979)  
**Heft:** P-21: An approximate method for the analysis of box girder bridges that are curved in plan  
  
**Artikel:** An approximate method for the analysis of box girder bridges that are curved in plan  
**Autor:** Al-Rifaie, W.N. / Evans, H.R.  
**DOI:** <https://doi.org/10.5169/seals-34084>

### **Nutzungsbedingungen**

Die ETH-Bibliothek ist die Anbieterin der digitalisierten Zeitschriften. Sie besitzt keine Urheberrechte an den Zeitschriften und ist nicht verantwortlich für deren Inhalte. Die Rechte liegen in der Regel bei den Herausgebern beziehungsweise den externen Rechteinhabern. [Siehe Rechtliche Hinweise.](#)

### **Conditions d'utilisation**

L'ETH Library est le fournisseur des revues numérisées. Elle ne détient aucun droit d'auteur sur les revues et n'est pas responsable de leur contenu. En règle générale, les droits sont détenus par les éditeurs ou les détenteurs de droits externes. [Voir Informations légales.](#)

### **Terms of use**

The ETH Library is the provider of the digitised journals. It does not own any copyrights to the journals and is not responsible for their content. The rights usually lie with the publishers or the external rights holders. [See Legal notice.](#)

**Download PDF:** 17.03.2025

**ETH-Bibliothek Zürich, E-Periodica, <https://www.e-periodica.ch>**

## **An Approximate Method for the Analysis of Box Girder Bridges that are Curved in Plan**

Méthode approchée pour le calcul de ponts courbes en caisson

Eine Näherungsmethode für die Berechnung von gekrümmten Brücken  
mit Kastenträger-Querschnitt

**W.N. AL-RIFAIÉ**

Lecturer  
University of Technology  
Baghdad, Iraq

**H.R. EVANS**

Senior Lecturer  
Department of Civil Engineering  
University College, Cardiff, GB

### **SUMMARY**

The paper describes the development of the nodal section method for the analysis of box girders curved in plan. The method makes certain assumptions about the structural behaviour and provides an economical solution process, suitable for use during the design stage. Results are compared with those obtained from a finite element analysis for box girders of different curvatures, of different cross-sectional proportions and material properties, under a variety of loading conditions. The degree of correlation obtained shows the accuracy of the proposed technique to be reasonable.

### **RÉSUMÉ**

L'article traite de la méthode de la section nodale pour le calcul de poutres en caisson courbes. La méthode est basée sur certaines hypothèses relatives au comportement structural; elle permet une marche à suivre économique et utilisable dans la pratique. Les résultats sont comparés avec ceux obtenus à l'aide du calcul par éléments finis pour des poutres en caisson de courbures différentes, de profils en travers et de matériaux différents, et pour des cas de charges variés. La bonne corrélation obtenue montre que la méthode proposée est raisonnable.

### **ZUSAMMENFASSUNG**

Der Artikel behandelt die Knotenschnitt-Methode zur Berechnung gekrümmter Kastenträger-Brücken. Die Methode basiert auf gewissen Annahmen mit Bezug auf das Tragverhalten und rührt zu einem wirtschaftlichen und in der Praxis brauchbaren Lösungsverfahren. Die mit diesem Verfahren hergeleiteten Resultate werden mit denjenigen aus Finite Element Methoden verglichen und zwar für verschiedene Krümmungsradien, Querschnittsformen, und Materialeigenschaften unter verschiedenen Belastungsarten. Der Vergleich zeigt die Genauigkeit der vorgeschlagenen Methode und beweist ihre Brauchbarkeit.



## 1. INTRODUCTION

In recent years, a simplified method of analysis has been developed [1] for straight box girder bridges. This method is known as "the nodal section method" and it has been developed specifically for use during the design stage when several analyses may be necessary to determine the optimum proportions of the structure; the availability of a simple and inexpensive method of analysis is then of great advantage.

However, modern highway schemes often require the design of box girders that are curved in plan. In this present paper, the development of the nodal section method to the analysis of such curved bridges will be described.

At present, the two methods most commonly used for the analysis of curved box girders are the finite element and finite strip methods. The accuracy of the finite element method has been firmly established [2,3,4], but a solution by this method requires a great deal of computer time and storage space and this, together with the extensive data preparation time involved, makes the method unsuitable for use during the preliminary design stage. Although a solution by the finite strip method [5,6,7] is much more economical than a finite element solution, it can still prove to be relatively expensive, since the method requires a Fourier series representation of the external loading; many terms of the series may be needed for the representation of certain loading conditions. Both these rigorous analytical techniques are well suited to the final analysis of a girder which has been designed on the basis of a number of preliminary analyses carried out by the nodal section method.

In a previous report [8], the Authors described an experimental investigation of curved box girders which established the accuracy of the finite element method in the analysis of such structures. In this present report, results obtained from the modified nodal section method will be compared to finite element values so that the accuracy of the proposed method can be assessed.

## 2. GENERAL THEORY AND ASSUMPTIONS

The nodal section method has been adapted from a technique used originally for the analysis of folded plate structures. The basic features of the method for the analysis of straight boxes have been described previously [1], so that attention will now be concentrated upon the additional considerations necessary in the case of curved boxes. Since the main advantage of the basic technique is its simplicity, all modifications have been governed by the need to retain this simplicity and, consequently, the economy of the solution procedure.

The nodal section method is currently restricted to the analysis of single-cell, simply-supported, curved girders. It is also assumed that the curved girder forms a segment of a circular arc, as shown in Fig. 1, with the end supports being positioned along radial lines. The end diaphragm plates are assumed to be infinitely stiff in their planes and perfectly flexible perpendicular to these planes.

In general, a component plate of a box girder is subjected to loading components both in its plane and perpendicular to its plane. It is assumed in the nodal section method that the bending action of each plate perpendicular to its plane can be represented by considering a series of transverse, one-way slab strips and that the in-plane bending action of each plate can be idealized as that of a beam spanning in the longitudinal direction between the supports.

The structural action is then considered to consist of the action of a series of one-way, transverse frames, elastically supported at the joints by a series of inter-connected longitudinal plate beams, as shown in Fig. 2. The frames are assumed to transmit shears and moments in the transverse direction only, whereas the plate beams are assumed to carry only those force components acting within their planes.

The structure is idealized by taking a number of arbitrarily spaced nodal sections in the radial direction. The dimensions of the girder cross-section must be specified at each nodal section, together with the loading applied at that section, so that the sections should be located to coincide with any changes in the box dimensions and with the positions of the applied loads.

### 3. ANALYTICAL PROCEDURE

The nodal section solution is carried out in a number of sequential steps, each step corresponding to a certain aspect of the physical behaviour of the girder. The transverse frame action is analyzed first, assuming the joints to be rigidly supported against vertical and horizontal movements. The calculated reaction forces are then applied in the reverse direction as joint loads on the longitudinal plate system and the longitudinal bending action is analyzed. Finally, a "sway correction" is carried out to allow for the true elastic interaction between the frame and plate systems.

Each step in the analysis will now be described individually. A fuller discussion of the complete solution has been presented by Al-Rifaie [9].

#### 3.1 Transverse Frame Analysis

This step simply involves the analysis of a series of independent frames subjected to external loading components perpendicular to the planes of the plates. A frame is positioned at each nodal section, as shown in Fig. 2, and the dimensions of a typical frame are shown in Fig. 3(a). To simplify the analysis, the curved inner and outer edges of the flange are replaced by the equivalent chord lengths so that the idealized frame unit consists of two plane, rectangular members representing the web plates and two plane trapezoidal

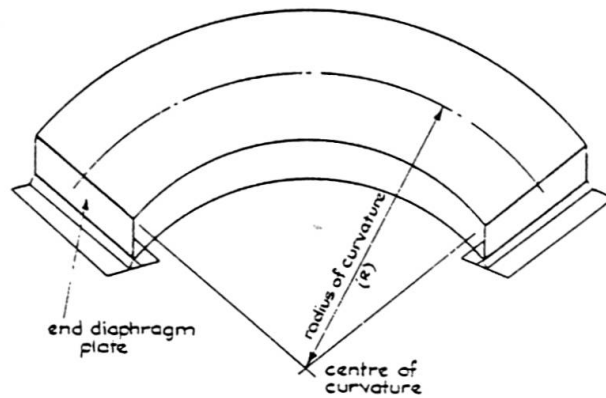

Fig. 1 Typical curved box girder considered in the analysis

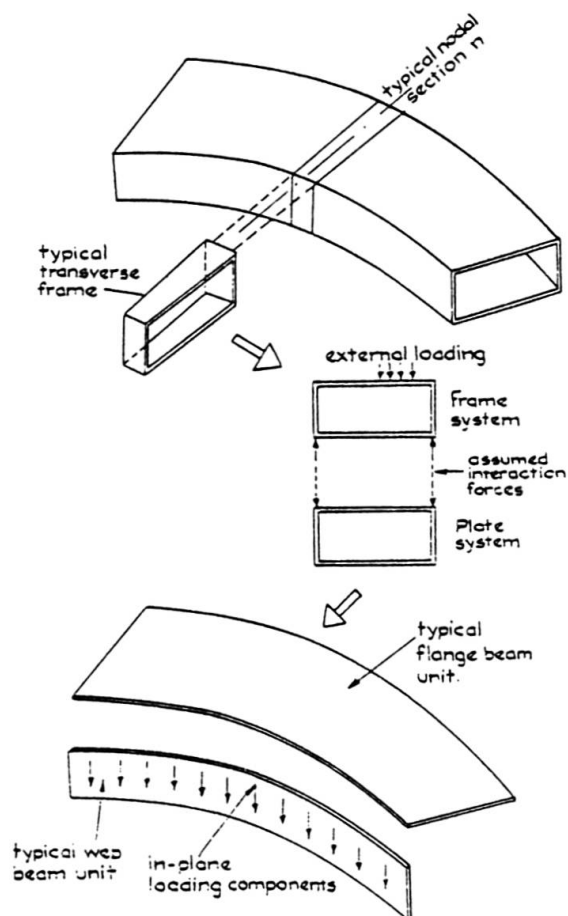

Fig. 2 Illustration of steps carried out in a typical nodal section analysis



members representing the flanges of the girder.

At this stage of the analysis, the joints of the frame are assumed to be supported against all translations, only joint rotations being permitted. The frame may be analyzed by a standard matrix technique in which the trapezoidal flange members are idealised by a series of rectangular beam elements, as shown in Fig. 3(b). Such an analysis will yield the values of the transverse moments at all nodal points, together with the lateral displacements of the unsupported nodes and the reaction forces developed at the joints.

A simplified approach to the transverse frame analysis, which does not require the use of matrix techniques, may also be adopted. The real frame of Fig. 3(a) may be replaced by the equivalent frame shown in Fig. 3(c), where the trapezoidal flange members are represented by equivalent rectangular members. The equivalent frame may then be analyzed by the slope deflection or moment distribution methods and it has been established by Al-Rifaie [9] that, for a girder having a radius of curvature of a practical magnitude, the simplified procedure can be adopted with little loss of accuracy but with a substantial saving of computational effort.

An identical analysis is carried out for each transverse frame unit and a series of joint reaction forces, representing the intensity of the reactions at each of the nodal sections, are obtained. By considering the appropriate arc lengths between adjacent sections, these reaction intensities are converted into equivalent point reactions at the nodal sections and are then applied in the reverse direction as point loads at the joints of the longitudinal plate system, as shown in Fig. 2.

### 3.2 Longitudinal Plate Analysis

Since it is assumed that the plates of the longitudinal plate system can only carry load components within their planes, the applied joint loads are resolved into components in the planes of the plates. The flange plates are thus loaded in their own planes of curvature, so that only in-plane bending moments are set up within them. The web plates are loaded in a direction perpendicular to their planes of curvature so that, in addition to in-plane bending moments, torsional moments are set up within the web plates; these torsional moments do not arise in the webs of straight box girders.

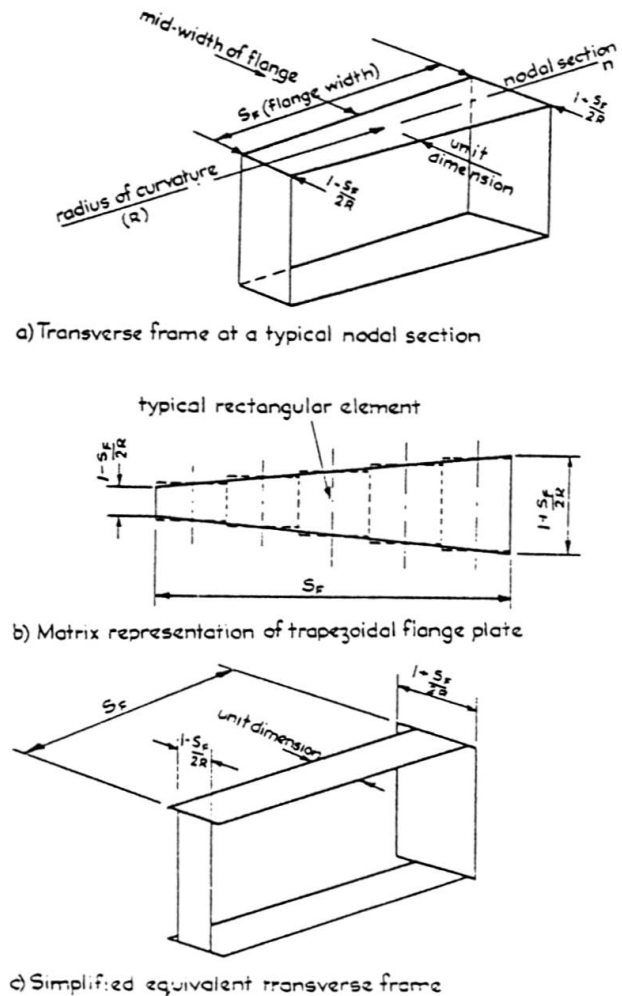

Fig. 3 Details of the transverse frame analysis

When a web plate twists out-of-plane under the action of the in-plane loading, the twisting displacement is resisted by the torsional resistance of the web plate itself and also by the in-plane bending resistance of the flange plates, since the twisting deflections of the web must be compatible with the in-plane bending deflections of the flanges. It has been shown by Al-Rifaie [9] that, for girders of normal proportions, the torsional resistance of the web may be neglected and all the resistance to the out-of-plane twisting of the web may be assumed to arise from the in-plane resistance of the flanges. This assumption enables the simplicity of the solution procedure to be maintained.

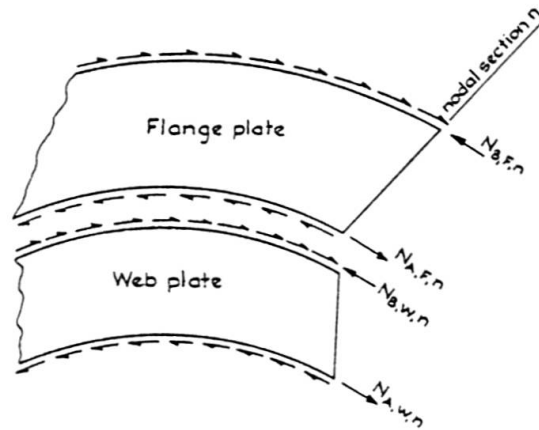

Fig. 4 Tangential forces at junction of web and flange plates

The behaviour of each component plate of the box girder is analysed individually and brief details of the procedures followed for typical web and flange plates are given in the Appendix. From these analyses a relationship is obtained between the tangential edge shear forces ( $N_A$  and  $N_B$ ) shown in Fig. 4, and the edge strains ( $\epsilon_A$  and  $\epsilon_B$ ) set up within each individual plate at each nodal section. These tangential edge forces are developed by virtue of the interaction between the webs and flanges and they may be determined by considering the equilibrium and compatibility conditions at the flange/web junctions.

Obviously, the tangential edge shear forces developed in the web must be in equilibrium with those developed in the flanges. For the typical case shown in Fig. 4, where edge B of the web plate intersects with edge A of the flange plate at a typical joint  $j$ , the equilibrium equation at nodal section  $n$  may be written as:-

$$N_{B,W,n} = N_{A,F,n} = N_{j,n} \quad (1)$$

The corresponding strain compatibility condition for this typical case may be expressed as:-

$$\epsilon_{B,W,n} = \epsilon_{A,F,n} \quad (2)$$

By substituting the expressions derived for the strains in the Appendix, a series of simultaneous equations are established involving the tangential joint forces  $N_{j,n}$  as unknowns. The number of equations at a particular nodal section is equal to the number of joints in the cross-section and solution of the equations yields the values of the joint forces. By repeating the procedure at each nodal section in turn, the joint forces throughout the whole girder are determined.

By substitution of these calculated forces into the expressions established in the Appendix, the longitudinal in-plane stresses in all the plates can be determined. Knowing these stresses at all nodal section positions, the in-plane displacements of each curved web and flange plate may be calculated. A simple resolution process at each joint then yields the vertical and horizontal components of the joint displacements of the box girder and completes the longitudinal plate analysis.



### 3.3 Sway Correction Procedure

During the transverse frame analysis, it was assumed that the joints of the frames were rigidly supported and that the required supports were provided by the longitudinal plate system. However, during the analysis of the longitudinal plate system, the joints were allowed to deflect so that, at the present stage of the analysis, the joint displacements of the plate and frame systems are incompatible.

These incompatibilities may be conveniently expressed in terms of the sway displacements set up within each plate at each nodal section; the sway displacement  $\Delta_{p,n}$  of a typical plate  $p$  at nodal section  $n$  is shown in Fig. 5 as an example. The object of the sway correction process is to remove these incompatibilities and an iterative technique has been developed to accomplish this. This iterative process, by employing an accelerator, ensures rapid convergence in all cases, so that the simplicity and economy of the nodal section solution are preserved.

Since the sway correction procedure for a curved box is identical to that described in detail for a straight box by Rockey and Evans [1], it will not be discussed further now. The application of the sway correction technique to curved boxes has also been described by Al-Rifaie [9].

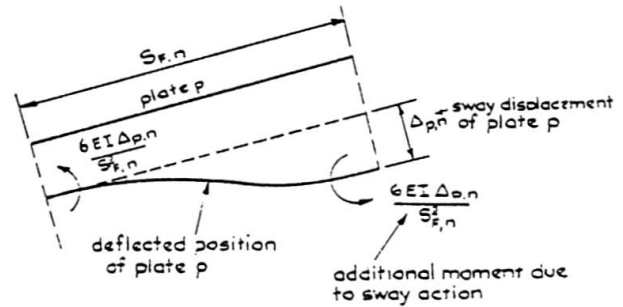

Fig. 5 Sway displacement of a typical plate

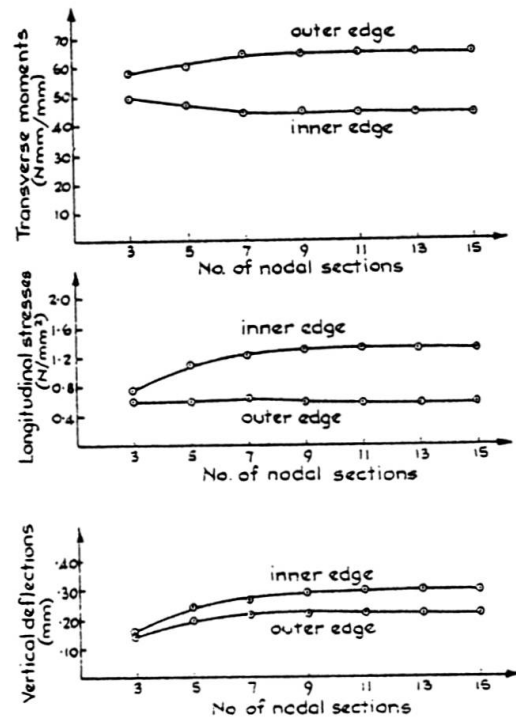

Fig. 6 Convergence of nodal section solution for a typical sand/araldite box

## 4. RESULTS

In order to establish the accuracy of the proposed method, the results obtained from the analysis of several curved box girder models will now be presented. The girders analysed were chosen so that the effects of the amount of curvature and of the loading conditions upon the accuracy of the solution could be observed. Furthermore, girders made from a mixture of sand and araldite, representing concrete boxes, and steel girders were studied to show the effects of material properties and cross-sectional dimensions.

The accuracy of the nodal section values will be assessed by a comparison with finite element results which were obtained from an established computer program [2].

Details of this finite element solution have been presented previously [8,9]

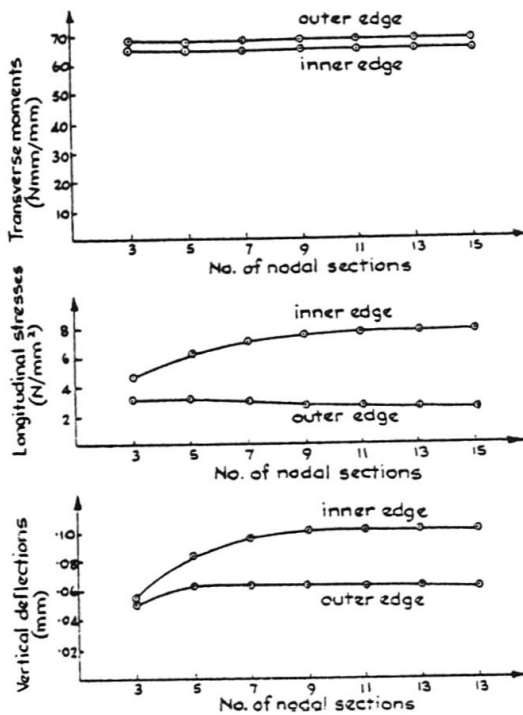
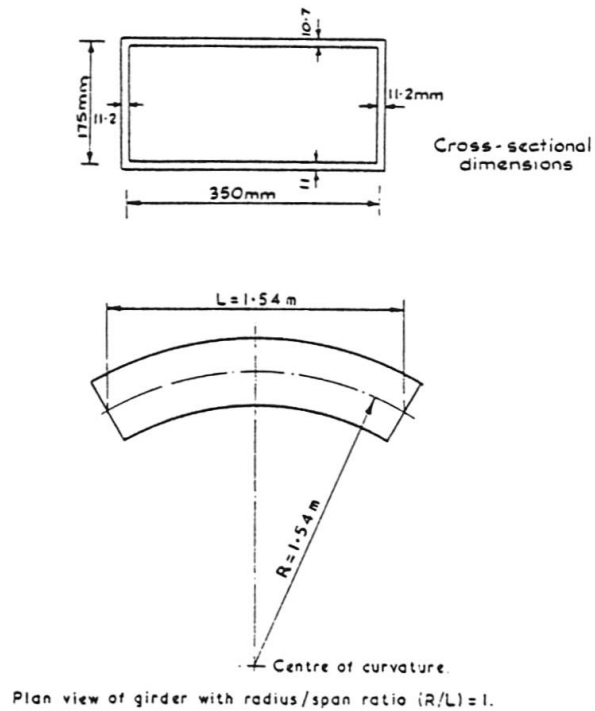

Fig. 7 Convergence of nodal section solution for a typical steel box

and it was established that a mesh containing 120 elements, 4 elements being positioned across the width of each flange and 1 element being positioned across the depth of each web, was capable of giving accurate results. Such a finite element mesh was used throughout the present investigation.

An idealisation of the structure is also required in the nodal section method and, in order to determine the rate of convergence of the solution, typical sand/araldite and steel girders, each having a radius/span ratio of 2 and being subjected to a uniformly distributed loading, were analyzed. Nodal section solutions involving 3, 5, 7, 9, 11, 13 and 15 sections, respectively, were carried out and the results obtained from the successive solutions are plotted in Figs. 6 and 7.

The values of most interest in design, viz. the transverse (radial) bending moments, the longitudinal (tangential) stresses and the vertical deflections at both the inner and outer edges of the models at mid-span, are plotted in the diagrams. For both the sand/araldite model in Fig. 6 and the steel model in Fig. 7, convergence is rapid and reasonably accurate results could be obtained by taking 7 nodal sections only. The solution is seen to have converged completely when 13 nodal sections are taken and such an idealization was thus adopted throughout the investigation.



Plan view of girder with radius/span ratio  $(R/L)=1$ .

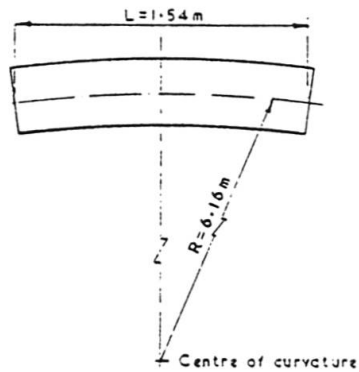

Plan view of girder with radius/span ratio  $(R/L)=4$ .

Fig. 8 Details of sand/araldite girders considered during study of the effects of curvature



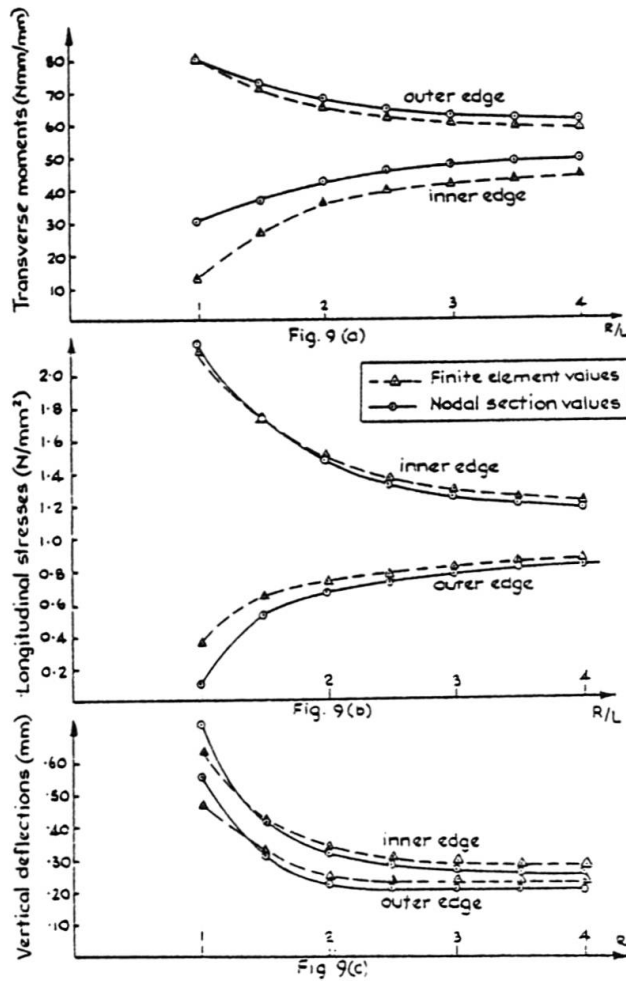

Fig. 9 Comparison of results for girders of different radius/ span ratios

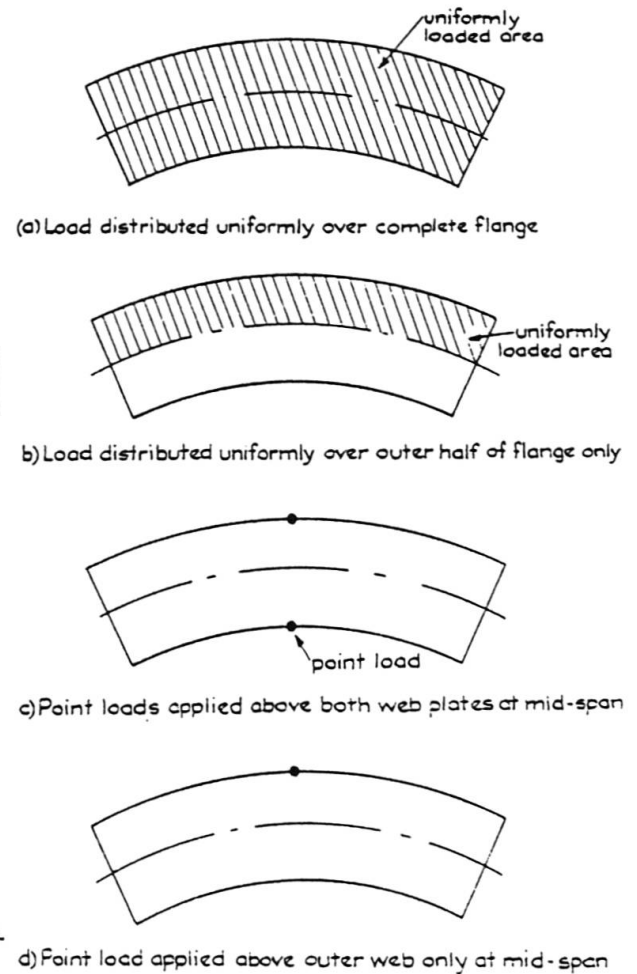

Fig. 10 Details of loading conditions considered

It was also established that a single cycle of the iterative sway correction procedure was sufficient to provide a convergent solution. The results presented were thus obtained by carrying out a single sway correction cycle at the mid-span cross-section.

#### 4.1 Effects of the Amount of Curvature

In order to determine the effects of the amount of curvature upon the accuracy of the nodal section method, sand/araldite girders having the cross-sectional dimensions defined in Fig. 8 were analyzed. Each model was subjected to a vertical loading, distributed uniformly over the complete area of the top flange and the overall span ( $L$ ) of the models was kept constant at 1.54 m throughout the complete study. The radius of curvature ( $R$ ) of the models was varied to give radius/span ratios ( $R/L$ ) of 1, 1.5, 2, 2.5, 3, 3.5 and 4. It is obvious from Fig. 8 that the range of curvature considered encompassed most practical girders.

The results obtained are shown in Figs. 9(a), 9(b) and 9(c). In these three diagrams, the variations of the transverse moments, the longitudinal stresses and the vertical deflections, respectively, with the radius/span ratio ( $R/L$ ) are plotted. Moment, stress and deflection values at both the inner and outer edges of the top flange plate at the mid-span cross-section are plotted.

In almost all cases, very good agreement between the nodal section and finite element values is observed for all values of the radius/span ratio. The only case where some inaccuracy is observed is in the transverse moments set up at the inner edge of the girder where the nodal section method overestimates the values throughout the whole R/L range. However, the general agreement between the two solutions confirms that the amount of curvature does not affect the accuracy of the nodal section procedure.

#### 4.2 Effects of Loading Conditions

The sand/araldite box with a radius/span ratio of 2 was chosen for the investigation of the influence of the applied loading conditions. This box was subjected to the four loading conditions illustrated in Fig. 10. In the first case the load was distributed uniformly over the complete area of the top flange. Then the load was distributed over the outer half of the flange width only to represent a lane loading. In the third case point loads were applied above each web plate at mid-span, and finally, a point load was applied above the outer web only at mid-span.

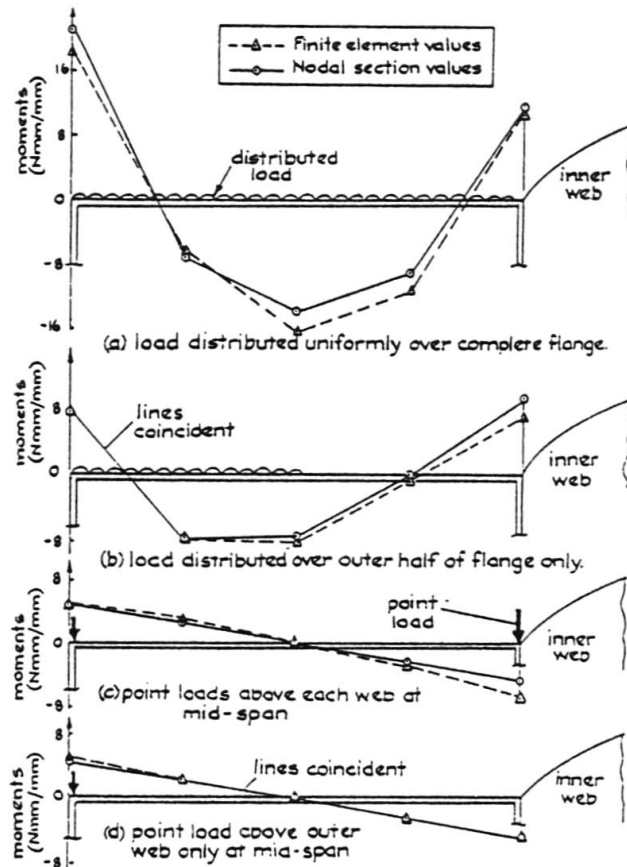

Fig. 11 Comparison of transverse moments in top flange at mid-span for different loading conditions

The values of the transverse bending moments developed in the top flange under the various loading conditions are shown in Fig. 11. The variation of the moments across the mid-span section is plotted for each loading case and the agreement between the two theoretical predictions is generally good.

In the distributed loading case, the large sagging moments developed at the centre of the flange, as a result of the local bending, are evident and are predicted with reasonable accuracy by the nodal section method. A large hogging moment is developed at the outer edge of the flange for the full distributed load case and this is again predicted accurately by the nodal section method.

Local bending within the flange plate does not occur in the edge load cases and, consequently, the variation of the moments across the flange width is virtually linear. Good agreement is again observed between the finite element and nodal section values.

The corresponding values of the longitudinal stresses for the four loading cases are compared in Fig. 12. Once again the variation of the stresses across the mid-span section of the top flange is plotted and, although the theoretical predictions are generally in good agreement with the experimental, some discrepancies are observed. These arise from the effects of shear lag within the top flange plate. Shear lag effects are not taken into account at present in the nodal section solution of curved boxes, and as a consequence, the stresses

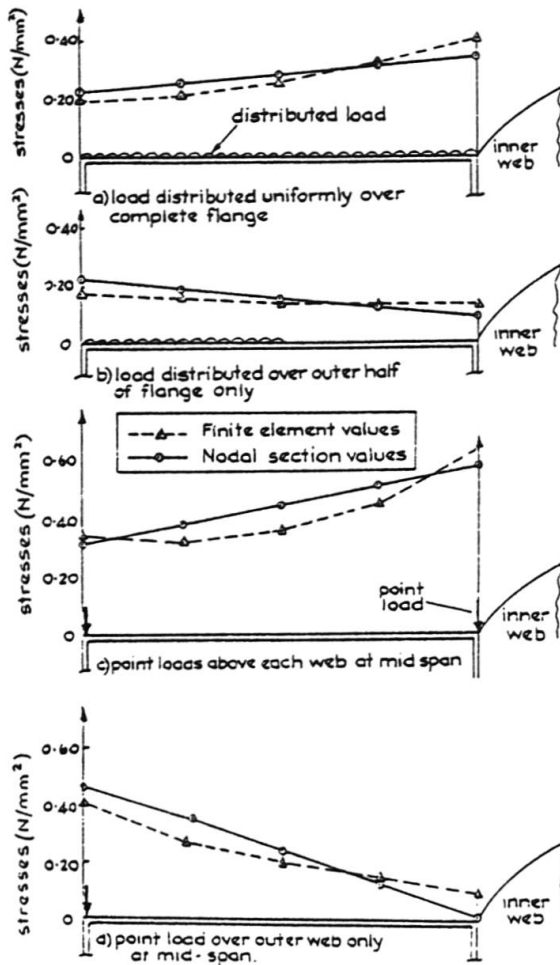

Fig. 12 Comparison of longitudinal stresses in top flange at mid-span for different loading conditions

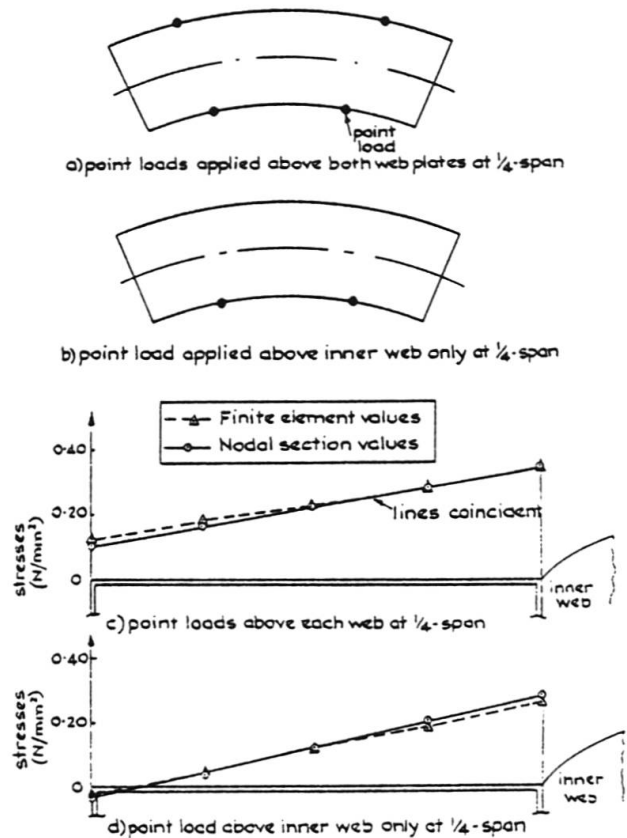

Fig. 13 Comparison of longitudinal stresses in top flange at mid-span for point loads applied at 1/4-span

predicted by the method vary linearly across the flange width. (In this case the non-linearity in the stress distribution arising from the effects of curvature is very small). The finite element values, on the other hand, show the parabolic variation of stresses arising from the effects of shear lag. By neglecting shear lag, the nodal section solution tends to underestimate the stresses developed at the edges of the flange and to overestimate the mid-flange stresses. The discrepancies are seen to be most marked for the two cases involving edge point loading and the shear lag effect is known [10,11] to be most significant in the region of such point loads.

Since it is also known [10,11] that the effects of shear lag die away rapidly with distance from the point load of application, two further solutions were considered where the applied loads were moved to the quarter-span cross-section. These two additional loading cases are illustrated in Figs. 13(a) and 13(b), with the loads being applied above both web plates at quarter-span in the first instance and then a single load being applied above the inner web only. This final load condition was in contrast to that shown in Fig. 10, since the mid-span point load was applied above the outer web plate.

The calculated longitudinal stress values at mid-span for these two additional loading cases are compared in Figs. 13(c) and 13(d). It is obvious that when the point loads are applied at quarter-span the mid-span stresses are not

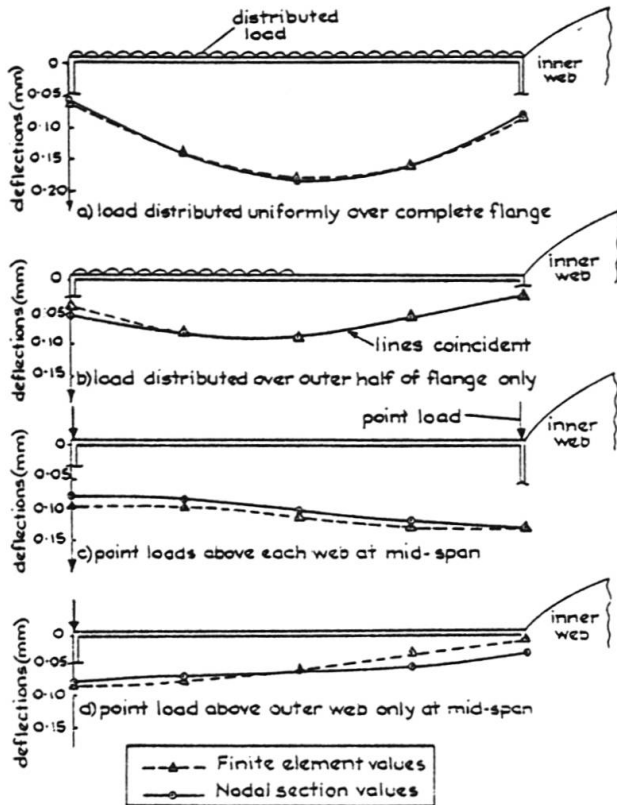

Fig. 14 Comparison of vertical deflections in top flange at mid-span for different loading conditions

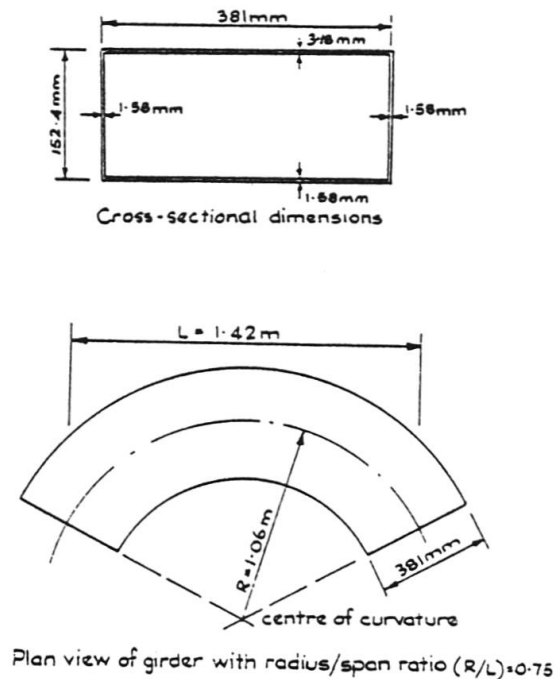

Fig. 15 Details of steel girder

affected by shear lag since the finite element stresses vary linearly across the flange width. The mid-span stresses predicted by the two methods are then in excellent agreement.

Finally, in Fig. 14, the predicted deflections for each of the four original loading cases are compared. Once again, the deflections of the top flange at the mid-span cross-section are plotted and it is clear that there is good correlation between the two sets of theoretical values.

Thus, other than for inaccuracies in the stress values developed close to positions of point load application, arising from the neglect of shear lag effects, the nodal section method is capable of taking a variety of different loading conditions into account in the analysis of curved box girders.

#### 4.3 Results for a Steel Model

In order to check the accuracy of the proposed method in the analysis of steel boxes, the steel girder shown in Fig. 15 was analyzed. The width/thickness ratio of the top flange plate of this girder was 120 compared to a ratio of 33 for the girders analyzed earlier. In addition, the radius/span ( $R/L$ ) ratio was reduced to 0.75 to produce a very severe curvature, as shown in Fig. 15, and thus provide a good test of the accuracy of the method. The model was subjected to a vertical loading distributed uniformly over the complete area of the top flange.



The theoretical predictions are compared in Figs. 16(a), 16(b) and 16(c), where the transverse moments, longitudinal stresses and vertical deflections, respectively, at the mid-span section of the top flange are plotted. In all cases the agreement is seen to be very good, showing that the change in material properties and cross-sectional proportions and the reduction in the radius of curvature has not affected the accuracy of the nodal section prediction.

## 5. CONCLUSIONS

The application of the nodal section method to the analysis of single-cell, curved box girders has been described in this paper. A detailed comparison of the results given by the method with those predicted by the finite element method has established the accuracy of the proposed method for boxes of different curvatures, of different cross-sectional proportions and material properties under a variety of loading conditions.

The method is being proposed as a tool for use during the design stage, when several analyses may be necessary to determine the optimum proportions. It is, therefore, of interest to note that whereas a typical finite element solution described in this report required 17 minutes of computer time, the corresponding nodal section solution only required 3 minutes. Equally substantial reductions were also made in data preparation efforts and in the interpretation of results.

The development of the method to allow for the effects of shear lag and for the analysis of multi-cell girders has already been successfully completed for straight girders. Similar developments are also being considered for curved girders.

## ACKNOWLEDGEMENTS

The investigation was carried out at the Department of Civil and Structural Engineering, University College, Cardiff. The Authors wish to thank Professor K.C. Rockey for placing the facilities of the Department at their disposal and for his encouragement.

The Authors are also indebted to the Highways Engineering Computing Branch of the Department of the Environment for the provision of the finite element program.

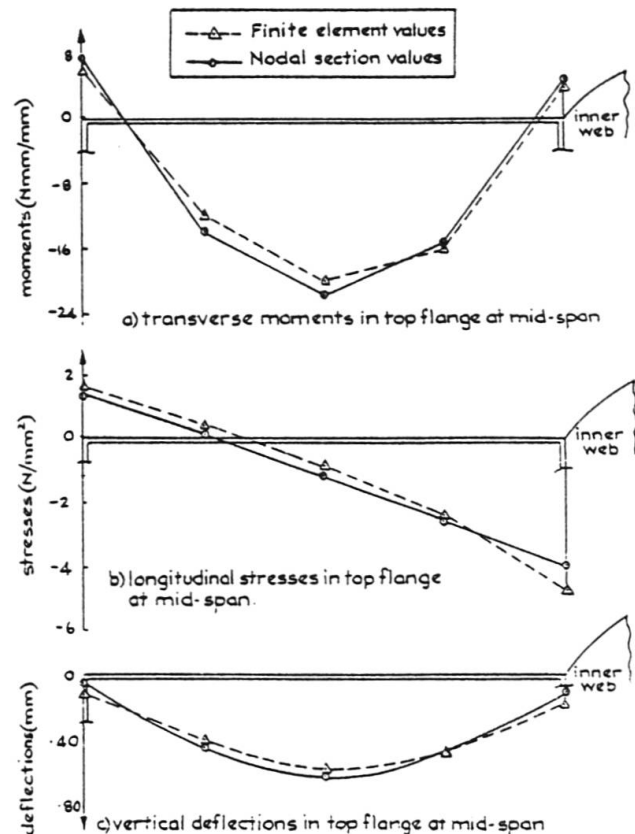

Fig. 16 Comparison of values for steel girders

## NOTATION

L	span
R	radius of curvature
n	number of typical nodal section
S <sub>F</sub>	width of flange plate
S <sub>W</sub>	depth of web plate
β	angle subtended at centre of curvature by successive nodal sections
Δ <sub>p,n</sub>	sway displacement of plate p at nodal section n
P <sub>P,W</sub>	loading component in plane of web plate
P <sub>P,F</sub>	loading component in plane of flange plate
N <sub>A,W</sub> & N <sub>B,W</sub>	tangential shears at edges of web plate
N <sub>A,F</sub> & N <sub>B,F</sub>	tangential shears at edges of flange plate
P <sub>T,W</sub>	radial twisting forces on web plate
P <sub>T,A</sub> & P <sub>T,B</sub>	radial twisting forces on flange plate
M <sub>W</sub>	moment in the plane of the web plate
M <sub>F</sub>	moment in the plane of the flange plate
σ <sub>A,W</sub> & σ <sub>B,W</sub>	stresses at edges of web plate
σ <sub>A,F</sub> & σ <sub>B,F</sub>	stresses at edges of flange plate

## REFERENCES

1. ROCKEY, K.C. & EVANS, H.R. "The nodal section method for the analysis of box girders", Publications of the Int. Assoc. for Bridge & Struct. Eng., Vol. 35-1, 1975.
2. HINTON, E. Report and User's Manual on box girder bridge analysis program - Centre for Numerical Methods in Engineering, University College, Swansea, 1973.
3. WILLIAM, K.J. & SCORDELIS, A.C. Computer program for cellular structures of arbitrary plan geometry - University College of California, Berkeley, 1970, Report UCSESM 70-10.
4. MOFFATT, K.R. & LIM, P.T.K. "Analysis of box girder bridges using higher order finite elements", Proc. of the Planning and Transport Research and Computation Conference on Bridge Structures, University of Warwick, 1975.
5. CHEUNG, Y.K. & CHEUNG, M.S. "Analysis of curved box girder bridges by the finite strip method", Publications of the Inst. Assoc. for Bridge & Struct., Eng., Vol. 31-1, 1971.
6. MEYER, C. & SCORDELIS, A.C. "Analysis of curved folded plate structures", Am. Soc. Civ. Engrs., Journal of Structural Division, ST.10, October, 1971.
7. LOO, Y.C. & CUSENS, A.R. "Developments of the finite strip method in the analysis of cellular bridge decks", Proceedings of Conference on Developments in Bridge Design and Construction (Cardiff), Crosby Lockwood, 1971.
8. EVANS, H.R. & AL-RIFAIE, W.N. "An experimental and theoretical investigation of the behaviour of box girders curved in plan", Proc. Instn. Civ. Engrs., Part 2, 1975, 59, June, pp. 323-352.
9. AL-RIFAIE, W.N. "Structural behaviour of curved box girder bridges", Ph.D. Thesis, University College, Cardiff, 1975.
10. MOFFATT, K.R. & DOWLING, P.J. "Shear lag in steel box girder bridges", Struct. Engr., 1975, 53, October, pp. 439-448.
11. EVANS, H.R. & TAHERIAN, A.R. "The prediction of the shear lag effect in box girders", Proc. Instn. Civ. Engrs., Part 2, 1977, 63, March, pp. 69-92.



## APPENDIX

Only a summary of the analytical procedure is presented in this Appendix. Full details have been presented by Al-Rifaie [9].

### Analysis of a Typical Curved Web Plate

Each web plate is analyzed as a curved beam, loaded in the direction perpendicular to its plane of curvature. An individual web beam unit, separated from the rest of the girder is shown in Fig. A.1, together with the loads considered to act upon it.

For the particular case shown, where the nodal sections are equally spaced and the loading is symmetrical about mid-span, the radial edge force at a typical nodal section  $n$  can be expressed as :

$$P_{T,W,n} = \frac{R}{2 S_W} \left[ \sum_{i=2}^{no-1} P_{P,W,i} [1 - \cos(n-1)\beta] - 2 \sum_{i=2}^{n-1} P_{P,W,i} [1 - \cos(n-i)\beta] \right] - \sum_{i=2}^{n-1} P_{T,i} \cos(n-i)\beta \quad (A.1)$$

Furthermore the in-plane bending moment at a typical section  $n$  is given by:-

$$M_{W,n} = \frac{R}{2} \left[ \sum_{i=2}^{no-1} P_{P,W,i} \sin(n-1)\beta - 2 \sum_{i=2}^{n-1} P_{P,W,i} \sin(n-i)\beta \right] + S_W \sum_{i=2}^{n-1} P_{T,W,i} \sin(n-2)\beta + (N_{A,W,n} + N_{B,W,n}) \cdot \frac{S_W}{2} \quad (A.2)$$

where sagging moments are considered to be positive.

The axial force on the cross-section at nodal section  $n$  may also be expressed in terms of the tangential edge forces as:-

$$P_{AX,W,n} = N_{A,W,n} - N_{B,W,n} \quad (A.3)$$

where tensile forces are considered to be positive.

By calculating the stresses and strains produced by these forces and moments, the required relationships between the edge strains ( $\Sigma_{A,W}$  and  $\Sigma_{B,N}$ ) and the tangential edge forces ( $N_{A,W}$  and  $N_{B,N}$ ) may be established for the web at each nodal section.

### Analysis of a Typical Curved Flange Plate

Each flange plate is analyzed as a curved beam, loaded in its plane of curvature. A typical flange beam, separated from the rest of the girder is shown in Fig. A.2, together with the loads considered to act upon it.

For the particular case of equally spaced nodal sections and loading that is symmetrical about mid-span, as in Fig. A.2, the in-plane bending moment at a typical nodal section  $n$  of the flange plate may be expressed as:-

$$M_{F,n} = \frac{R}{2} \left[ \sum_{i=2}^{n-1} (P_{P,F,i} + P_{T,i}) \sin(n-1)\beta - \sum_{i=2}^{n-1} (P_{P,F,i} + P_{T,i}) \sin(n-i)\beta \right] + (N_{A,F,n} + N_{B,F,n}) \cdot \frac{S_F}{2} \quad (A.4)$$

When a curved beam bends within its plane of curvature, the neutral axis is displaced from the centroid of the section towards the centre of curvature and the distribution of the bending stress across the section becomes non-linear. For a beam of rectangular cross-section, a modification factor  $f$  may be incorporated within the stress formula for a straight beam to enable the stresses in a curved beam to be obtained.

By calculating the stresses and strains developed within the flange by the applied moments and forces, the required relationships between the edge strains ( $\Sigma_{A,F}$  and  $\Sigma_{B,F}$ ) and the tangential edge forces ( $N_{A,F}$  and  $N_{B,F}$ ) may be established for the flange plate at each nodal section.

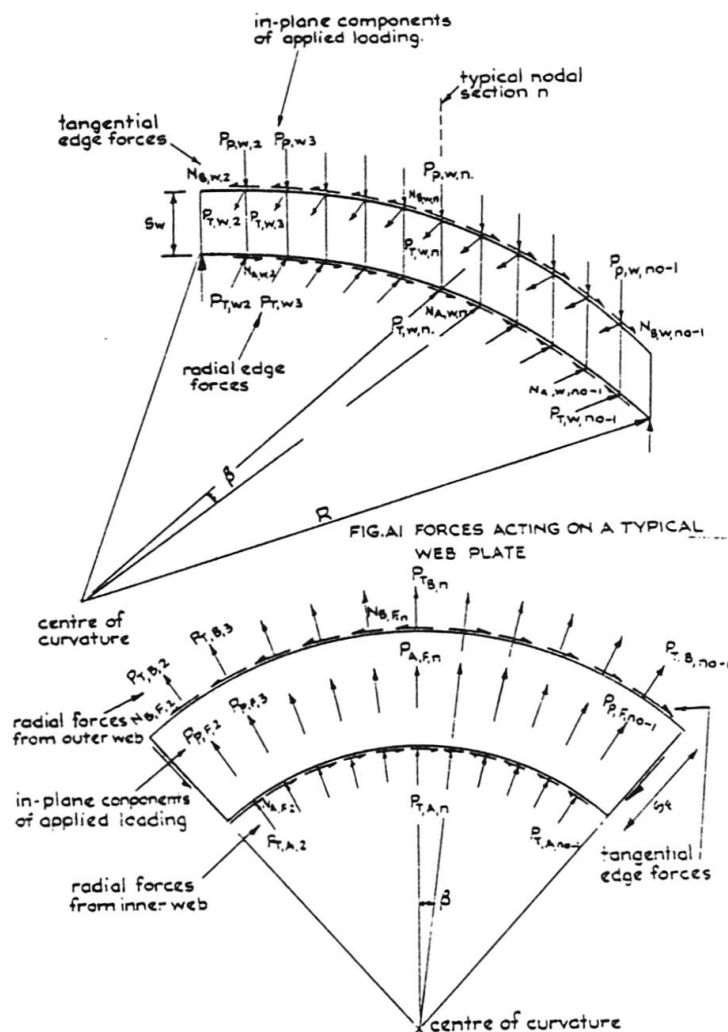

Fig. A.2 Forces acting on a typical flange plate