

Zeitschrift: IABSE proceedings = Mémoires AIPC = IVBH Abhandlungen
Band: 6 (1982)
Heft: P-51: On the theory of ship collision against bridge piers

Artikel: On the theory of ship collision against bridge piers
Autor: Saul, Reiner / Svensson, Holger
DOI: <https://doi.org/10.5169/seals-36657>

Nutzungsbedingungen

Die ETH-Bibliothek ist die Anbieterin der digitalisierten Zeitschriften. Sie besitzt keine Urheberrechte an den Zeitschriften und ist nicht verantwortlich für deren Inhalte. Die Rechte liegen in der Regel bei den Herausgebern beziehungsweise den externen Rechteinhabern. [Siehe Rechtliche Hinweise.](#)

Conditions d'utilisation

L'ETH Library est le fournisseur des revues numérisées. Elle ne détient aucun droit d'auteur sur les revues et n'est pas responsable de leur contenu. En règle générale, les droits sont détenus par les éditeurs ou les détenteurs de droits externes. [Voir Informations légales.](#)

Terms of use

The ETH Library is the provider of the digitised journals. It does not own any copyrights to the journals and is not responsible for their content. The rights usually lie with the publishers or the external rights holders. [See Legal notice.](#)

Download PDF: 17.03.2025

ETH-Bibliothek Zürich, E-Periodica, <https://www.e-periodica.ch>

On the Theory of Ship Collision against Bridge Piers

Collision de bateaux contre des piles de ponts

Zur Theorie des Schiffstosses gegen Brückenpfeiler

Reiner SAUL

Senior Eng.

Leonhardt und Andrä, Consult. Eng.
Stuttgart, Fed. Rep. of Germany



Reiner Saul, born in 1938, Dipl.-Ing. of Civil Engineering, Univ. of Hannover in 1963. Four years with a steel contractor; since 1971 senior supervising engineer with Leonhardt und Andrä. He was responsible for the design, technical direction and checking of numerous long-span bridges, including also major rehabilitation works.

Holger SVENSSON

Project Eng.

Leonhardt und Andrä, Consult. Eng.
Stuttgart, Fed. Rep. of Germany

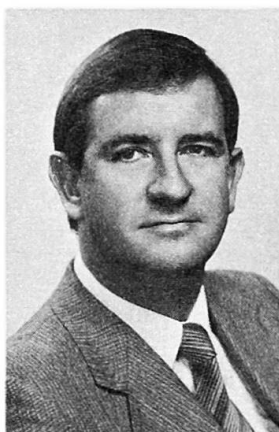

Holger Svensson, born in 1945, Dipl.-Ing. degree in Structural Engineering, Univ. of Stuttgart in 1969. After two years of work in Southern Africa he joined Leonhardt und Andrä, where he works as a Project Engineer on all aspects of the design of long-span bridges.

SUMMARY

The paper outlines methods to calculate the energies and impact forces occurring during the collision of a ship with a bridge pier. A rational design of pier protections and/or the required strength of a pier itself is thus facilitated.

RÉSUMÉ

Les méthodes du calcul de l'énergie de choc et des efforts de choc qui agissent au moment du choc d'un bateau contre une pile de pont sont présentées. Les formules indiquées facilitent le calcul des piles mêmes et le projet des dispositifs de protection contre le choc d'un bateau.

ZUSAMMENFASSUNG

Es werden Methoden zur Berechnung der Stossenergie und der Stosskräfte beim Anprall eines Schiffes auf einen Brückenpfeiler angegeben. Die angegebenen Formeln erleichtern den Entwurf von Schutzeinrichtungen gegen Schiffsanprall und die Bemessung der Pfeiler selbst.



1. GENERAL

In various countries general investigations on ship collisions with bridge piers have been conducted on behalf of certain bridge designs and numerous accidents in the past [1] to [6], appendix.

In the following the impact energies and impact forces occurring during a collision are being investigated. A general survey on protection measures is given in [7].

2. IMPACT MECHANICS

The impact mechanics may be subdivided into internal and external mechanics [8], [9] and [10].

2.1 External Impact Mechanics

The external mechanics may be categorized in the summary impact theory for free bodies, in the investigation of the influence of the surrounding water and in the estimation of the elastic impact energy portion. The summary theory permits, as we know, the calculation of the impact energy without knowing the impact forces, by means of the principles of maintenance of energy, impulse and torsion.

The influence of the surrounding water is approximated through the introduction of a hydrodynamic supplementary mass. For the acceleration in the direction of the ship's length, this supplementary mass may be assumed to be constant with about 5% of the ship's displacement.

Experiments were undertaken in Italy, Japan and West Germany to calculate the supplementary mass for the lateral acceleration. The findings were that the increase depends upon the ship's acceleration and the impact duration, and may amount to 1,8 of the ship's mass ([8], Fig.3).

In shallow water the supplementary mass increases, according to the German experiments, still up to maximally 1,7 times more as compared to deep water ([8], Fig.5).

While the overwhelming portion of the impact energy is transformed to heat through plastic deformation and surface friction work, certain small portions of the energy are also converted into elastic deformation work and hydrostatic energy, such as sinking-, trimming- and heeling work. These portions can, however, be left out of consideration in general, that is, in the summary impact theory the value for the elastic back-resilience can be given as zero.

2.2 Internal Impact Mechanics

The impact force in a ship's collision is essentially dependent upon the deformation resistance of the structural elements hitting each other.

The impact force $P(t)$ is a function of the damage length $a(t)$ on ship and pier. The relation $P = f(a)$ depends, however, essentially upon the structural elements involved in the impact, that is, upon their common dynamic deformation resistance. Upon the amount of the kinetic energy only depends at which damage length the closing-in movement ceases, Figure 1.



Fig.1 Impact force P and energy E in relation to the damage length a . From [8]

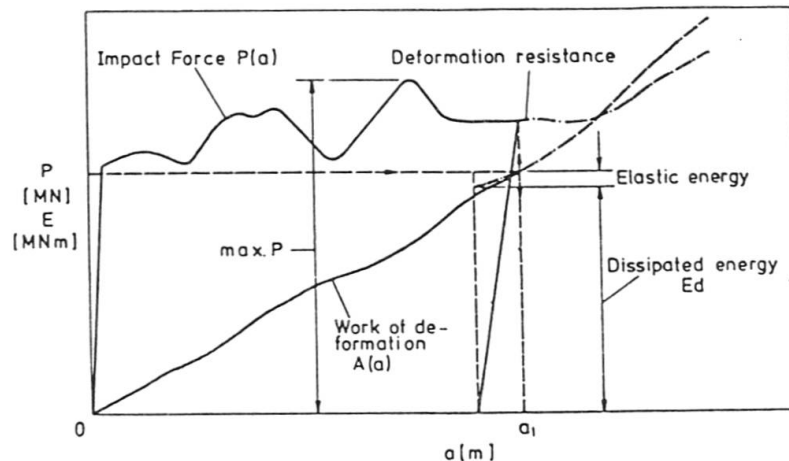

Minorsky has systematically investigated collisions between ships for the design of the American nuclear powered ship N/S "Savannah", [11]. The finding of that study was that a linear correlation exists between the volume of the ship's steel deformed in the collision of both ships and the absorbed energy, Figure 2.

Minorsky's formula, modified as per [10], yields the following for the case of a right-angle collision between two ships where the struck ship has no speed:

$$\Delta E = \frac{\mu}{\mu + 1} \frac{m_1 \cdot v_1^2}{2}$$

$$\Delta W = aR + b$$

with

ΔE : the part of the damage-causing kinetic energy, which is transformed

ΔW : the energy absorbed in the area of the damage, $\Delta W = \Delta E$

$\mu = \frac{m_2}{m_1}$: mass relation of the striking to the struck ship. The hydrodynamic additional masses are contained in m_1 and m_2

$\frac{1}{2}m_1v_1^2$: kinetic energy of the striking ship

a, b : constants
 $a = 47 \text{ MNm/m}^3$
 $b = 32 \text{ MNm}$

R : Volume of the steel deformed in the area of the damage [m^3]

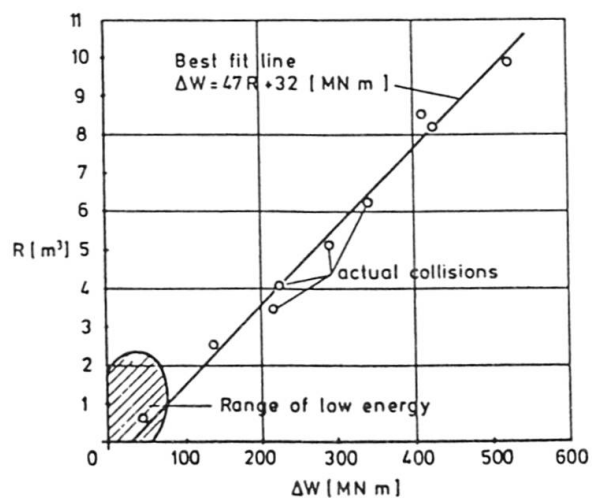

Fig.2 Relation between absorbed energy ΔW and deformed steel volume R for collisions between two ships. From [11]

Since its publication in 1975, the correctness of the Minorsky formula has been confirmed continuously through the results of real collisions and model tests.

3. APPLIED COLLISION ENERGY IN IMPACT ON A PIER

The impact of a ship against a stiff body can be treated in accordance with the process indicated by Woisin in [8] for the external mechanics of ship's collisions.



The kinetic energy of a ship moving straight forward amounts to

$$E_K = \frac{1}{2} \cdot \frac{m_1 + \Delta m}{m_1} \cdot m_1 v_0^2$$

with

m_1	the ship's mass
Δm	hydrodynamic supplementary mass
$\frac{m_1 + \Delta m}{m_1}$	excess factor for the hydrodynamic supplementary mass
v_0	ship's speed.

The excess factor for the hydrodynamic supplementary mass in longitudinal direction is set as 1,05, in lateral direction as 1,5 due to the short impact duration.

Thereby the kinetic energy of the ship before the impact amounts to

$$E_{K,v} = \frac{1}{2} \cdot 1,05 \cdot m_1 \cdot v_0^2$$

With a striking point in the ship's centerline the special treatment of the ship's cross translation and the rotation can be avoided by introducing a reduced impact mass:

$$m_{red} = 1,5 \cdot m_1 \cdot \frac{i^2}{i^2 + r^2}$$

with

i	distance impact location — ship's gravity center
r	mass radius of inertia.

An elliptic mass distribution over the ship's length and a negligibly small mass distribution over the ship's width is assumed which renders $i = L/4$ and $r = L/2$ ($L =$ ship's length) and

$$m_{red} = 0,3 m_1$$

Further, it is assumed (Figure 3a):

- the striking ship has only longitudinal speed
- the impact angle to the pier amounts to α
- the friction factor μ between ship and pier presupposes $|P_T| = \mu |P_N|$
- the friction is constant during the impact.

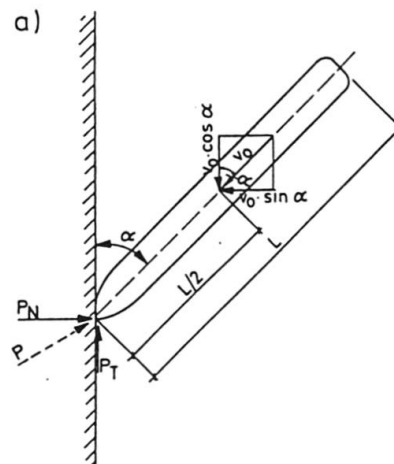

Fig.3a Geometry during impact



The impulses I_N and I_T (Figure 3b) effect with their components normal and parallel to the ship's axis corresponding speed changes at the ship's bow (simplified, $|I|$ is set equal to I in the following):

$$\begin{aligned} \Delta_{Nv_c} &= \frac{I_N \sin \alpha}{1,05 \text{ m}_1} \\ \Delta_{Nv_q} &= \frac{I_N \cos \alpha}{0,3 \text{ m}_1} \\ \Delta_{Tv_c} &= \frac{I_T \cos \alpha}{1,05 \text{ m}_1} \\ \Delta_{Tv_q} &= \frac{I_T \sin \alpha}{0,3 \text{ m}_1} \end{aligned}$$

with $I_T = \mu I_N$

Summed up we have for $\mu \leq \frac{1}{\tan \alpha}$ (otherwise we set $\mu = \frac{1}{\tan \alpha}$)

$$\begin{aligned} \Delta v_\ell &= \Delta_{Nv_\ell} + \Delta_{Tv_\ell} = \frac{I_N(\sin \alpha + \mu \cos \alpha)}{1,05 \text{ m}_1} \\ \Delta v_q &= \Delta_{Nv_q} + \Delta_{Tv_q} = \frac{I_N(\cos \alpha - \mu \sin \alpha)}{0,3 \text{ m}_1} \end{aligned}$$

For the speed component v_N normal to the pier of the impact speed v_0 at the end of the impact we have

$$v_N = v_0 \sin \alpha \rightarrow 0$$

From that follows

$$(v_0 \sin \alpha - \Delta v_\ell \sin \alpha - \Delta v_q \cos \alpha) \rightarrow 0$$

or

$$v_0 \sin \alpha = I_N \left[\frac{(\sin \alpha + \mu \cos \alpha) \sin \alpha}{1,05 \text{ m}_1} + \frac{(\cos \alpha - \mu \sin \alpha) \cos \alpha}{0,3 \text{ m}_1} \right]$$

Thereby we can calculate the normative size of the impact impulse normal to the wall

$$i_N = \frac{I_N}{v_0 \text{ m}_1 \cdot 1,05} = \frac{\sin \alpha}{\sin^2 \alpha + \mu \sin \alpha \cos \alpha + (\cos^2 \alpha - \mu \sin \alpha \cos \alpha) \frac{1,05}{0,3}}$$

To determine the applied impact energy, the left-over kinetic energy $E_{K,h}$ is determined:

$$v_{\ell,h} = v_0 - \Delta v_\ell = v_0 - \frac{I_N}{1,05 \text{ m}_1} (\sin \alpha + \mu \cos \alpha) = v_0 - i_N v_0 (\sin \alpha + \mu \cos \alpha)$$

$$v_{q,h} = -i_N v_0 \frac{\cos \alpha - \mu \sin \alpha}{0,286}$$

$$E_{K,h} = \frac{1}{2} \cdot 1,05 \text{ m}_1 v_{\ell,h}^2 + \frac{1}{2} \cdot 0,3 \text{ m}_1 v_{q,h}^2$$

$$\begin{aligned} e_{K,h} &= \frac{2E_{K,h}}{1,05 \text{ m}_1 v_0^2} = \left(\frac{v_{\ell,h}}{v_0} \right)^2 + \frac{0,3}{1,05} \left(\frac{v_{q,h}}{v_0} \right)^2 \\ &= \left(1 - i_N \frac{\sin \alpha + \mu \cos \alpha}{1,05} \right)^2 + 0,286 i_N^2 \left(\frac{\cos \alpha - \mu \sin \alpha}{0,3} \right)^2 \end{aligned}$$

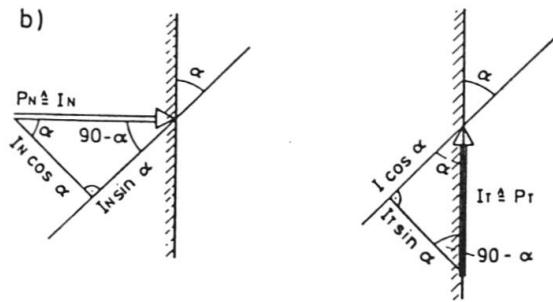

Fig.3b Angle relations during impact



The applied kinetic energy (collision energy) to be transformed by the ship and/or the pier into another energy form is hence

$$\Delta E = E_{K,v} - E_{K,h} = \eta E_{K,v}$$

with $\eta = 1 - e_{K,h}$

(for $\mu \geq \frac{1}{\tan \alpha}$ we have $\eta = 1$),

see Figure 4.

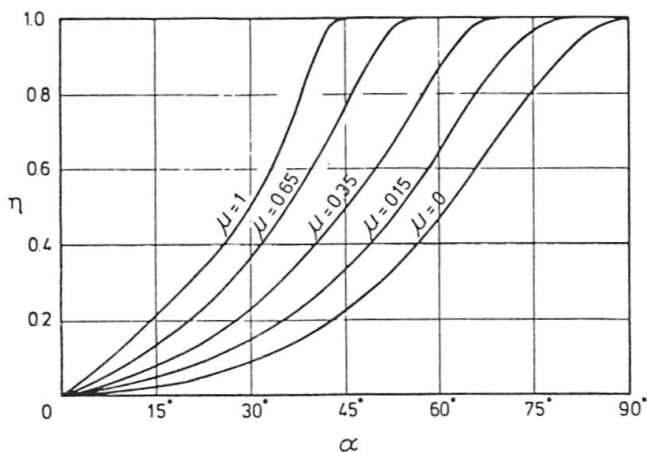

$$\eta = \frac{\text{absorbed collision energy}}{\text{initial ship's energy}}$$

Fig.4 Part of collision energy η to be absorbed by the ship and/or pier in relation to the collision angle α and the friction μ

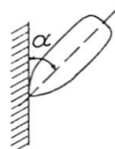

Friction	μ	
Steel - steel	~ 0.15	
Steel - concrete	~ 0.35	
Steel - wood	~ 0.65	

4. FORCES OF A RIGHT-ANGLE IMPACT AGAINST A STIFF PIER

These impact forces can be deduced from measurements in collision tests which were conducted for the most part in Japan, Italy and West Germany for the purpose of developing collision protection for nuclear vessels.

In Germany the "Gesellschaft für Kernenergieverwertung in Schiffbau und Schifffahrt GmbH (GKSS)" and Howaldtswerke - Deutsche Werft AG, conducted in the years 1967-76 a total of 24 collision tests with 12 ship's model pairs with a scale of 1:7,5 and 1:12. Models of passenger liners, tankers and container ships of up to 195,000 dwt capacity were examined.

From that it was estimated that the medium impact force

$$P_m = \frac{\Delta E}{a} \quad (a: \text{length of damage})$$

is approximately constant during the collision. The maximum impact force P_{max} increases at the beginning of the impact for approximately 0.1 - 0.2 seconds to double the amount of P_m , Figure 5.

Fig.5 Impact forces from a collision test between the bow models of the passenger liner T/S Bremen against the side model of the N/S Otto Hahn, Test No.1 of the GKSS. From [12]

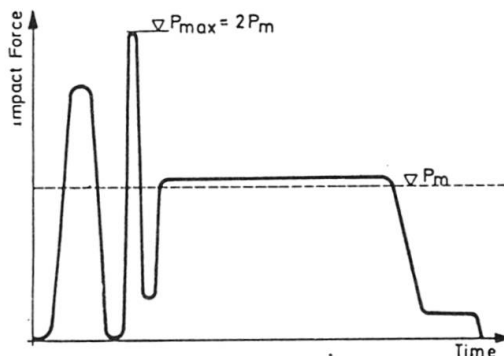

The correlation between absorbed energy and damage length for the 195,000 dwt large tanker, the "Esso Malaysia" (Figure 6a) is shown in Figure 6b. It is evident from this that a ballast water filling of the fore peak shortens the length of the damage and increases the medium impact force by up to 50%. The reason for this is found in the stiffening effect of the water filling which provides an increased deformation resistance because of its incompressibility.

In the collision tests of the GKSS it turned out that the maximum impact forces for a given ship's construction were only in second order — after forward-quarter type and ship size — dependent upon the kinetic energy of the ship. From the results of these tests Woisin concluded for bulk carriers that the effective maximum impact force for an impact against a stiff pier follows in first approximation the formula

$$P_{max} \approx 0,88 \sqrt{dwt} \pm 50\%$$

Figure 7, with

P_{max} : greatest impact force in [MN],

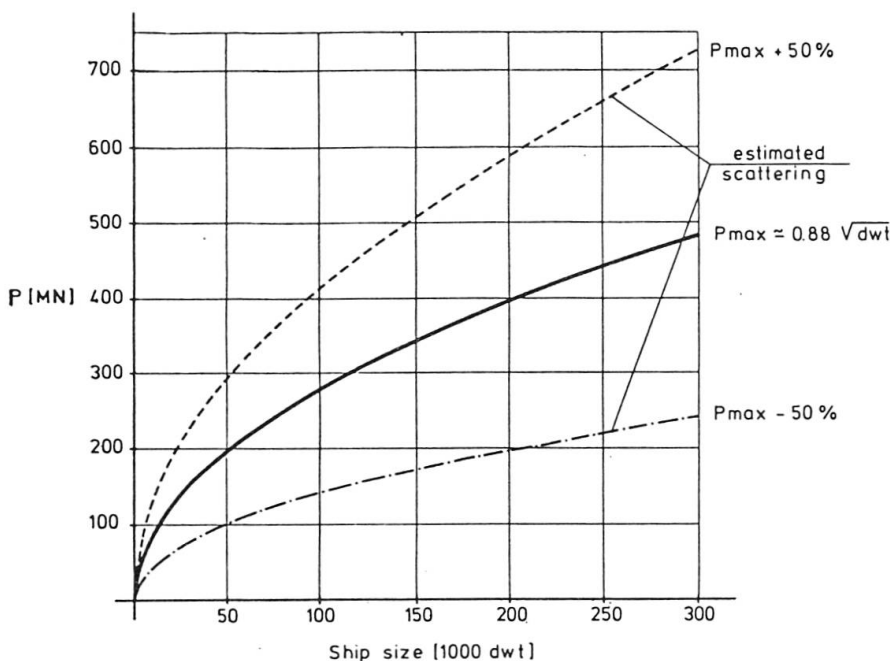

Fig.7
Approximation for the relation between the impact force P and ship's size [dwt] for bulk carriers.
From [2]

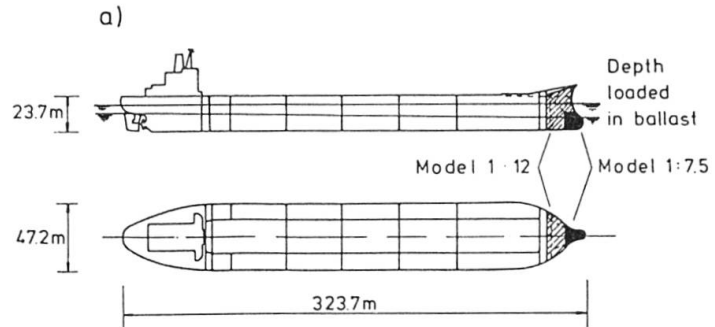
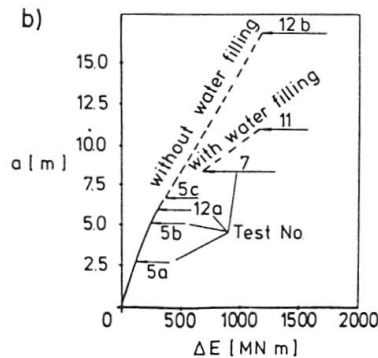

Fig.6 Collision tests of the GKSS with 195,000 dwt tanker "Esso Malaysia"
From [9]
a) Bow model



b) Relation between the collision energy ΔE and the damage length a in true size



dwt: carrying capacity in [t] as identification for the type of ship's structure. The correlation between volumes in GRT (1 Gross Register Ton = 100 ft³ = 2.83 m³) the carrying capacity in dwt (1 deadweight ton = 1LT = 2240 lbs = 10.16 kN) and the water displacement in [t] $\hat{=}$ [m³ water] is shown in Figure 8.

Fig.8 Relation between displacement [t], load carrying capacity [dwt] and volume [GRT] for various types of ships.

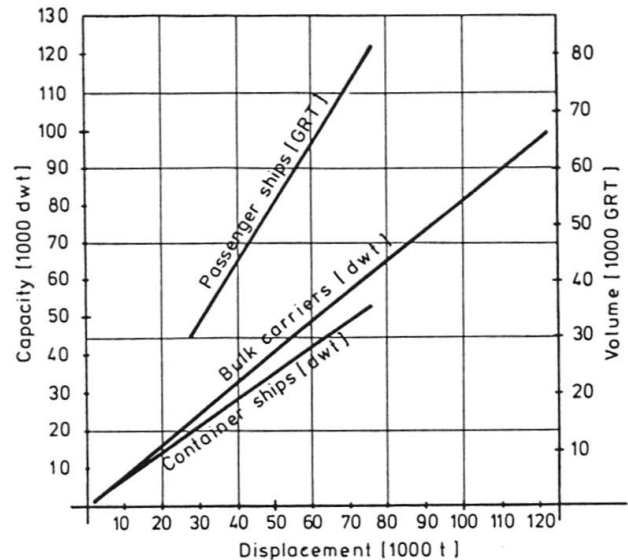

The variation of $\pm 50\%$ depends among other things on the structural type of the forward-quarter of ships of the same size, on the external shape, on the type of internal stiffening and on the degree to which the fore peak has been filled with water.

The medium impact force P_m over the duration of the impact in accordance with Fig.5 amounts to about

$$P_m \approx 1/2 P_{max}$$

and the corresponding damage length a becomes

$$a = \frac{\Delta E}{P_m} \text{ [m]}$$

5. EXAMPLES FOR EQUIVALENT LOADS FOR SHIP IMPACT

On February 19, 1981, a tanker with 45,000 t displacement collided with one of the main piers of the Newport Bridge, Rhode Island, USA. The massive foundations remained undamaged with the exception of local concrete spalling [13]. The ship's bow was flattened over a distance of 3,5 m.

Calculations in accordance with section 4 would render:

Ship: tanker with 45,000 t displacement $\hat{=}$ 38,000 dwt

$$\begin{aligned} \text{max. impact force } P_{max} &= 0,88 \sqrt{dwt} \pm 50\% = 0,88 \sqrt{38.000} \pm 50\% = \\ &= 172 \pm 86 \text{ MN} \end{aligned}$$

This force acts only over about 0,1 to 0,2 sec.

$$\text{Average impact force } P_m = 1/2 P_{max} = 86 \pm 43 \text{ MN}$$



Ship's

$$\text{kinetic energy: } E_K = 1/2 \cdot m \cdot v^2 \cdot 1,05 = 1/2 \cdot 45 \cdot 3^2 \cdot 1,05 = \\ = 213 \text{ MNm}$$

$$\text{damage length: } a = \frac{\Delta E}{P_m} = \frac{213}{86 \pm 43} = 2,48 \begin{matrix} +2,48 \\ -0,83 \end{matrix} = \\ = 4,96/1,65 \text{ m}$$

The actual damage length of 3,5 m indicates a relatively soft bow.

In 1961 a 35,000 dwt ore carrier (displacement 50,000 t) with a speed of about 4 m/sec collided with a circular dolphin of 13,7 m in 11 m deep water [17]. The dolphin rotated so that its upper portion was displaced by about 3,5 m. The ship's bow was crushed by about 1,5 m ("several feet"). A calculation of the average impact force renders, assuming plastic behaviour and a central impact:

$$E_{Kin} = 420 \text{ MNm} \\ P_m = \frac{420}{3,5 + 1,5} = 84 \text{ MN}$$

In accordance with section 4 the following is obtained:

$$P_m \cong 1/2 \times 0,88 \sqrt{35000} = 82 \text{ MN} \\ a = \frac{420}{82} = 5,1 \text{ m}$$

In the new German Railway Code an equivalent load of 30 MN for piers of bridges across the Rhine River is stipulated [14]. This load was determined for a barge with 1800 t displacement (1350 dwt), a speed above ground of 5,88 m/sec and a damage length of 2 m. From section 4 we would arrive at

$$P_{max} = 32,3 \text{ MN} \\ \Delta E = 32,7 \text{ MNm} \\ a = 2,0 \text{ m}$$

The similarity between actual and predicted results is quite good, considering the possible variations.

REFERENCES

1. Ostenfeld, Ch.: Ship Collisions against Bridge Piers. Publications IABSE, 1965, p.233-277
2. Frandsen, A.G., Langso, H.: Ship Collision Problems:I. Great Belt Bridge,II. International Enquiry. Publications IABSE, 1980, p.81-108
3. v.Olnhausen, W.: Pasesgling av bropelare (Ship Impact against Bridge Piers), Teknisk Tidskrift 1966, p.17
4. Maunsell and Partners with Brady, P.J.E.: Second Hobart Bridge, Report on Tasman Bridge - Risk of Ship Collision and Methods of Protection. September 1978
5. Saudi-Danish Consultants, Saudi Arabia-Bahrain Causeway, Design Memorandum No.4, Review of Ship Impact on Bridge Piers. Riyadh, Copenhagen, August 1978
6. Honshu-Shikoku Bridge Authority: Study Report on the Navigational Safety of the Honshu-Shikoku Bridges. Tokio, 1973



7. Saul, R. and Svensson, H.: Zum Schutz von Brückenpfeilern gegen Schiffsanprall (On the Protection of Bridge Piers against Ship Collision). Die Bau-technik 58(1981), p.326-335, 374-388
8. Woisin, G.: Schiffbauliche Forschungsarbeiten für die Sicherheit kernenergiegetriebener Handelsschiffe (Ship-structural Investigation for the Safety of Nuclear Powered Trading Vessels). Jahrbuch der Schiffbautechnischen Gesellschaft, Volume 65(1971) Berlin, Heidelberg, New York, p.225-263
9. Woisin, G.: Die Kollisionsversuche der GKSS (The Collision Tests of the GKSS). Jahrbuch der Schiffbautechnischen Gesellschaft, Volume 70(1976) Berlin, Heidelberg, New York, p.465-487
10. Woisin, G.: Konstruktion gegen Kollisionsauswirkungen (Structures against the Effects of Ship Collision). Schiff und Hafen/Kommandobrücke 31(1979), Vol.12, p.1059-1069
11. Minorsky, V.U.: An Analysis of Ship Collision with Reference to Protection of Nuclear Power Plants, Journal of Ship Research 3(1959), 2,1
12. Woisin, G. and Gerlach, W.: Beurteilung der Kräfte aus Schiffsstößen auf Leuchttürme in See (Valuation of Forces due to Ship Collision on Off-shore Lighthouses). German Technical Reports for the Eighth International Seamark Conference, Stockholm 1970
13. Parsons, Brinckerhoff, Quade and Douglas: Newport Bridge Collision. New York 1981
14. Deutsche Bundesbahn: Vorschrift für Eisenbahnbrücken und sonstige Ingenieurbauwerke /VEI (Prescriptions for Railway Bridges and other Civil-Engineering Structures). Voraussgabe der DV 804, Section 113

APPENDIX: Examples for Ship Collisions

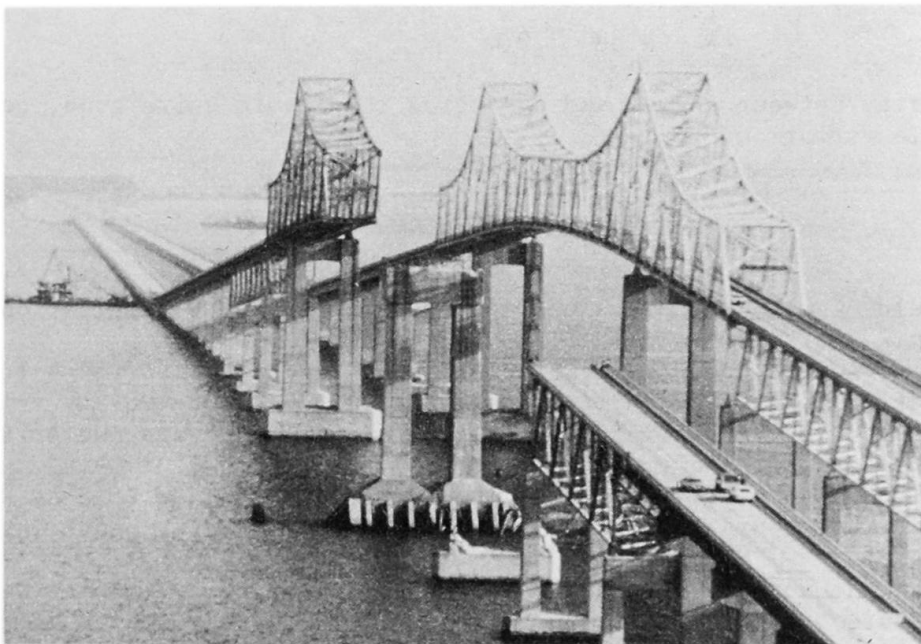

Sunshine-Skyway Bridge over Tampa Bay, Florida, USA.
Hit on February 9, 1980, by a 20.000 t - freighter. 33 persons killed.
Photo: Courtesy of James E.Sawyer, Greiner Engineering, Tampa, USA

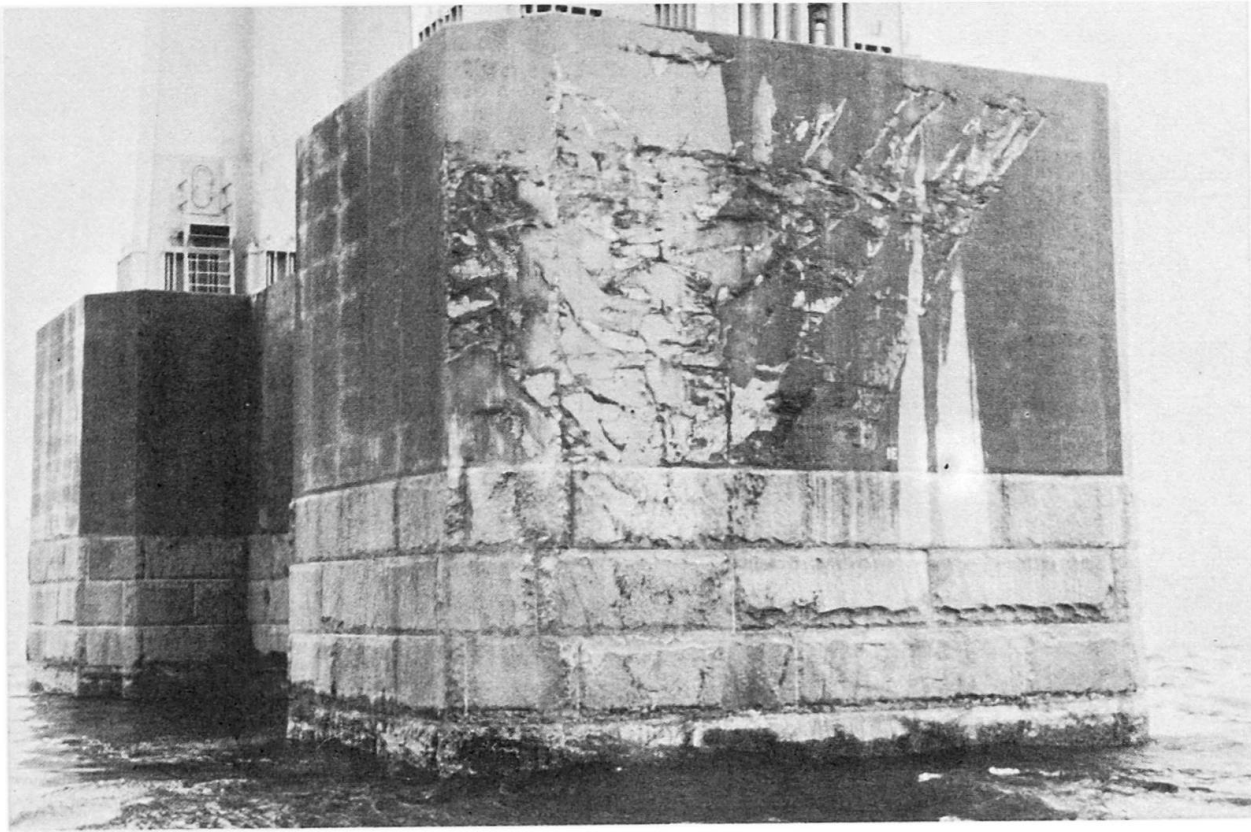

Newport Bridge over Narragansett Bay, Rhode Island, USA.
Hit on February 19, 1981, by a 45.000 t - tanker.
Photos: Courtesy of Thomas R. Kuesel, Parsons, Brinckerhoff,
New York, USA

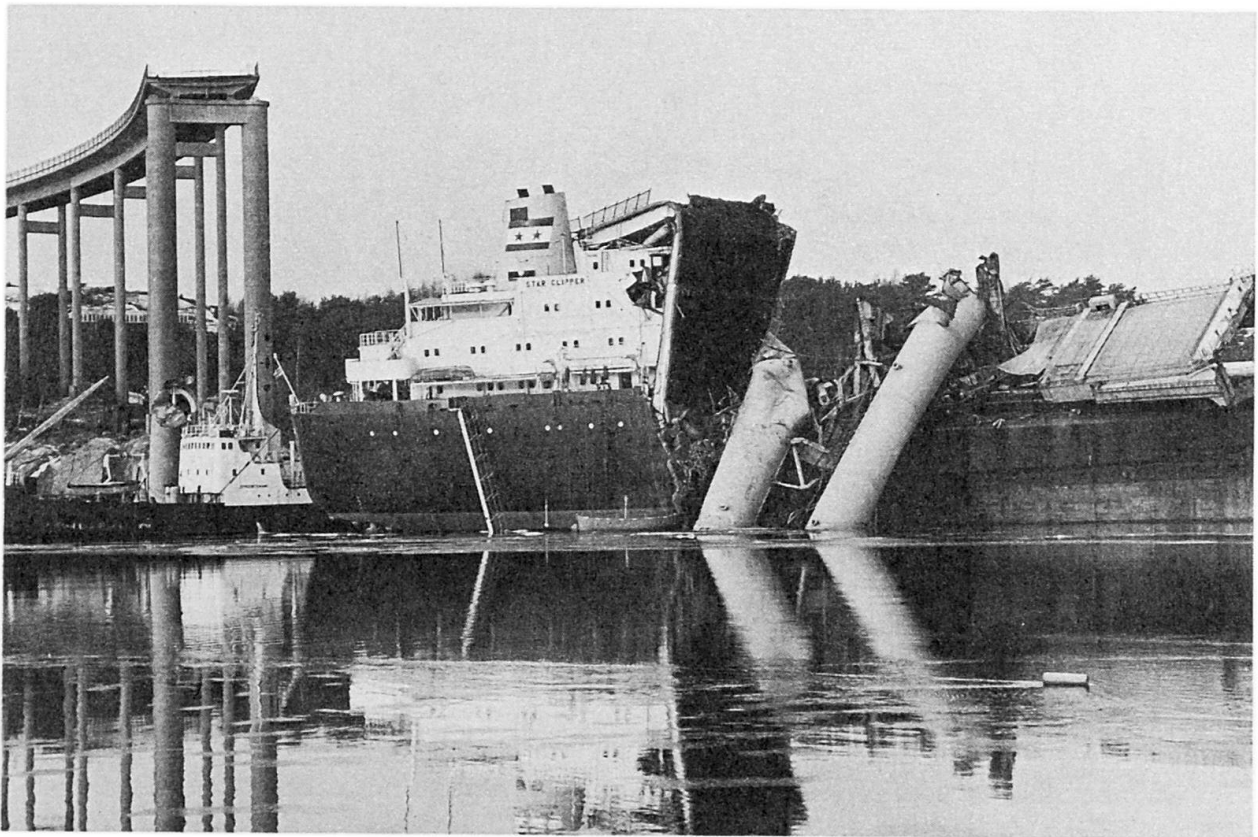
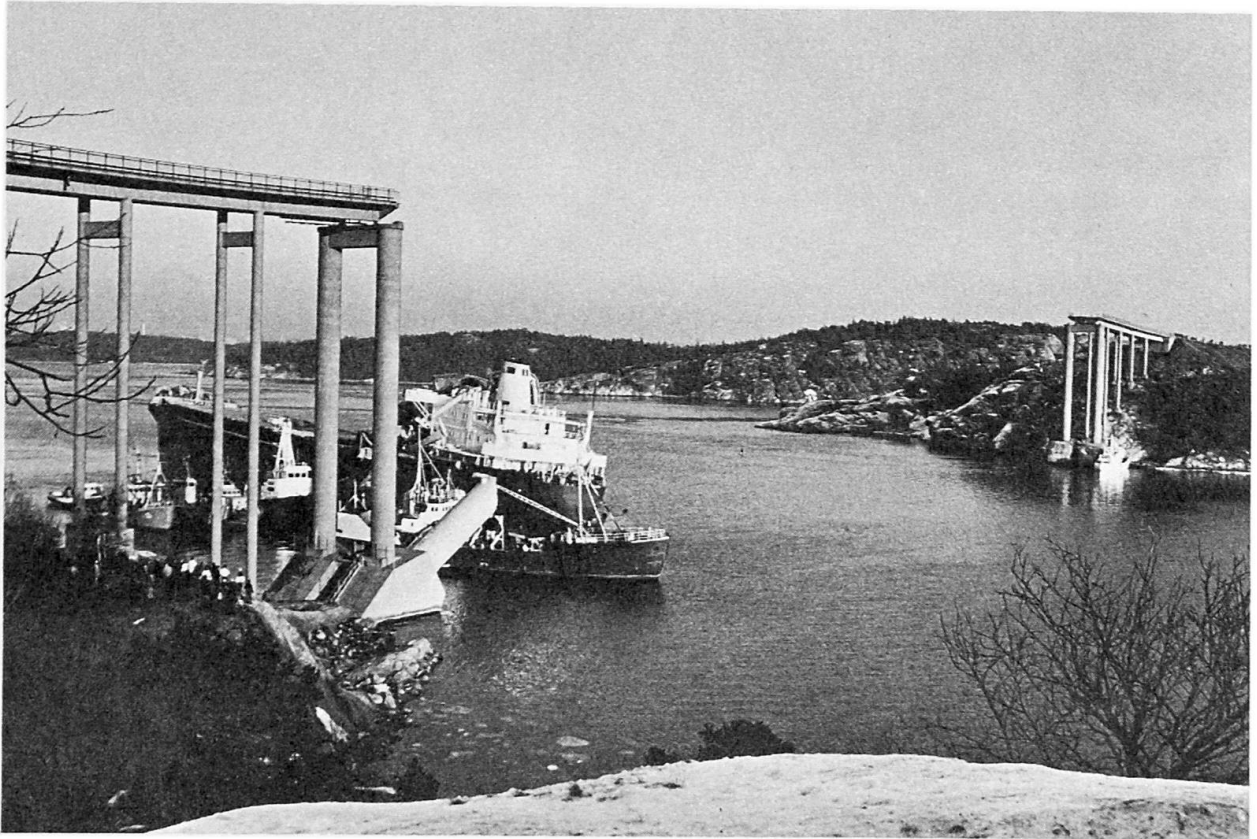

Almö-Bridge over the Askeröfjord, Sweden
Hit on January 18, 1980, by a 15.000 t - freighter. 8 persons killed.
Photos: Courtesy of Construction News, London, England