

Zeitschrift: IABSE proceedings = Mémoires AIPC = IVBH Abhandlungen
Band: 8 (1984)
Heft: P-77: Design of reinforced concrete columns subjected to imposed end deformations

Artikel: Design of reinforced concrete columns subjected to imposed end deformations
Autor: Thürlimann, Chris B.
DOI: <https://doi.org/10.5169/seals-38339>

Nutzungsbedingungen

Die ETH-Bibliothek ist die Anbieterin der digitalisierten Zeitschriften. Sie besitzt keine Urheberrechte an den Zeitschriften und ist nicht verantwortlich für deren Inhalte. Die Rechte liegen in der Regel bei den Herausgebern beziehungsweise den externen Rechteinhabern. [Siehe Rechtliche Hinweise.](#)

Conditions d'utilisation

L'ETH Library est le fournisseur des revues numérisées. Elle ne détient aucun droit d'auteur sur les revues et n'est pas responsable de leur contenu. En règle générale, les droits sont détenus par les éditeurs ou les détenteurs de droits externes. [Voir Informations légales.](#)

Terms of use

The ETH Library is the provider of the digitised journals. It does not own any copyrights to the journals and is not responsible for their content. The rights usually lie with the publishers or the external rights holders. [See Legal notice.](#)

Download PDF: 29.03.2025

ETH-Bibliothek Zürich, E-Periodica, <https://www.e-periodica.ch>

Design of Reinforced Concrete Columns Subjected to Imposed End Deformations

Dimensionnement des colonnes en béton armé soumises à des déformations imposées

Bemessung von Stahlbetonstützen bei aufgezwungenen Endverformungen

Chris B. THÜRLIMANN

Dr. Eng.
Swiss Fed. Inst. of Technology
Lausanne, Switzerland

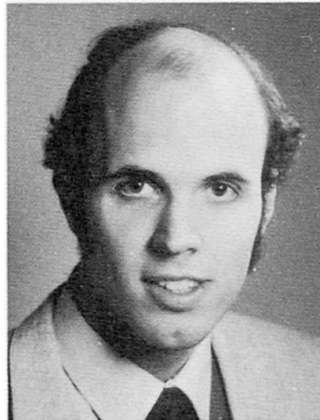

C. Thürlimann worked for Freeman Fox & Partners, Consulting Engineers, London after graduation at the Swiss Federal Institute of Technology Zürich in 1977. Since autumn 1979 he has been at the Swiss Federal Institute of Technology Lausanne where he obtained his PhD in structural engineering in 1984.

SUMMARY

A new design concept is presented for braced reinforced concrete columns in buildings and bridges. Such columns do generally not fail when their flexural resistance is reached. They simply start to develop plastic hinges. It is proposed to design these columns by considering the normal forces and the imposed end deformations. Methods for the check of the ultimate and serviceability limit states are given.

RÉSUMÉ

Un nouveau concept de dimensionnement est présenté pour des colonnes en béton armé retenues horizontalement. La rupture de ces colonnes n'a généralement pas lieu lorsque la résistance à la flexion est atteinte. Il se forme tout simplement des rotules plastiques. On propose de dimensionner ces colonnes en considérant les efforts normaux et les déformations imposées aux extrémités. Des méthodes de vérification des états-limites ultimes et d'utilisation sont données.

ZUSAMMENFASSUNG

Vorgestellt wird ein neues Konzept für den Entwurf von seitlich gehaltenen Stahlbetonstützen. Bei solchen Stützen tritt normalerweise kein Bruch ein, wenn der Biege widerstand erreicht wird. Die Stützen beginnen einfach plastische Gelenke auszubilden. Es wird vorgeschlagen, diese Stützen unter Berücksichtigung der Normalkräfte und der aufgezwungenen Endverformungen zu bemessen. Es werden Methoden für den Nachweis der Trag- und Gebrauchsfähigkeit präsentiert.



1. INTRODUCTION

In the design of columns it is necessary to distinguish between load and deformation problems.

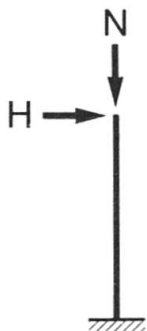
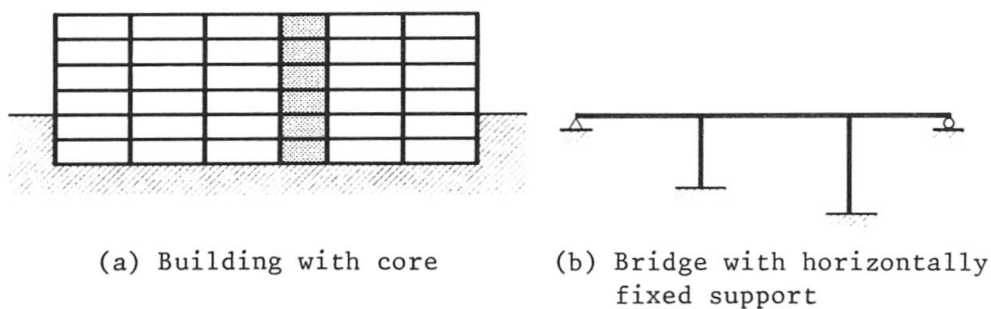

Fig. 1 shows a cantilever column. Either the column fails as soon as the maximum resistance is reached at the base of the column or, in the case of a very slender column, through instability before the maximum resistance is reached at the base. This problem is termed a load problem.

Fig. 1 Load Problem



(a) Building with core

(b) Bridge with horizontally fixed support

Fig. 2 Deformation Problems

Fig. 2 shows two examples of braced columns. These problems are deformation problems. The horizontal loads are taken by the core or the fixed support, respectively. The columns are primarily loaded by a normal force. Bending occurs through imposed end deformations, which can be either rotations and/or displacements. An asymmetric load on the beams produces a rotation of the column ends. A relative change in the length of the beams due to temperature or shrinkage causes a horizontal displacement of the column ends.

The actual design actions in such reinforced concrete columns are quite difficult to estimate. It is difficult to make precise calculations for the moments because of crack formation in the concrete, nonlinear time dependent material behaviour, as well as geometrical nonlinearity in case of slender columns. Results of an elastic analysis are very often used for the determination of the moments acting at the column ends. Many times calculations are omitted and eccentricities of the normal force are chosen to determine the end moments. The column is then treated as an isolated element and analysed with the two previously determined end moments. An amplification factor, which takes the column slenderness ratio into account, is finally used to determine the maximum flexural moment for the design together with the normal force.

This method of column design using the normal force and estimated end moments

may lead to unlogical conclusions: the ultimate load capacity for a hinged column would be greater than for a fixed ended column, which is subjected to compression and bending. Only the hinged column would be able to allow large horizontal displacements, or rotations of the beams. On the other hand the column with rigid connections would quickly reach its maximum flexural resistance. In order to eliminate moments at the column ends, expensive and unnecessary solutions such as concrete hinges, knife edges, roller supports or neoprene hinges are often chosen.

It is however well known that a rigid connection of the columns is not only cheaper but that it also increases the strength of the structure with respect to instability. The fact that the buckling length for hinged columns is greater than for fixed ended columns indicates that the ultimate load capacity of built-in columns should in general be greater.

The erroneous conclusions result from the fact that the column has been isolated from the rest of the structure for the analysis. Consequently, the nonlinear interaction of the column with the structure is neglected. For example, the column does not fail when the maximum flexural resistance has been reached at the base of the column. A plastic hinge will simply be formed in the column, which allows further large deformations to occur.

A new design method is proposed which attempts to solve these problems of imposed deformations. The design of a column is carried out by considering the normal force and the imposed angle (Fig. 3) due to the interaction of the column with the beam.

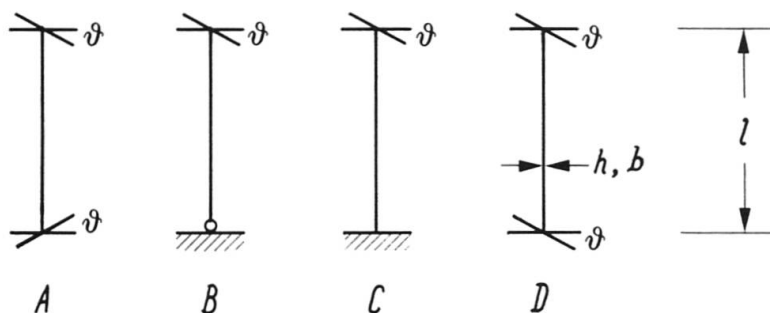

Fig. 3 Deformation Cases

2. DESIGN CONCEPT

The proposed column design is based on limit state considerations. The serviceability and the ultimate limit states of a column are verified by comparing the imposed angles at the column ends with the respective limit angles. The latter depend on the level of the applied normal force. The imposed angles have to be smaller than the limit angles of the columns.

The material behaviour of the concrete is time dependent. The imposed deformations can either be short term, or long term for which creep has to be considered. The two limit states will therefore be checked for the time t_0 and t_∞ .



2.1 Serviceability Limit State

The imposed deformation on columns in service should neither cause excessive cracking nor spalling of the concrete cover. This condition is fulfilled if the imposed angle under service load ϑ is smaller than the admissible limit angle θ_a :

$$\vartheta < \theta_a \quad (2.1)$$

2.2 Ultimate Limit State

The columns shall be able to carry the vertical load up to the formation of a failure mechanism in the beams. The large deformations which occur before a mechanism is finally established in the beam clearly indicate the impending collapse of the structure. Such a failure mode is preferable to a sudden collapse. The load capacity of a column is sufficient if the imposed angle under ultimate load ϑ_r is smaller than the maximum limit angle θ_m :

$$\vartheta_r < \theta_m \quad (2.2)$$

For cases B, C and D (Fig. 3) the method is limited to columns which reach the maximum flexural resistance at the column end. In case A, the maximum flexural resistance is reached at midspan. In practice most building columns and also short columns in bridges are hence covered.

The definition of possible strains and curvatures in a column (chapter 4) allows the estimation of the admissible and maximum limit angle (chapter 5) for a given deformation. A control of the column slenderness and the applied normal force (chapter 6) shows whether or not the second order influence has to be checked. Simple methods are used for the estimation of the imposed angles (chapter 7).

Firstly, the deformation behaviour of reinforced concrete columns under imposed end deformations will be discussed.

3. BEHAVIOUR OF COLUMNS SUBJECTED TO IMPOSED END DEFORMATIONS

Load controlled tests on reinforced concrete columns are not suitable to demonstrate the ductility of the columns because failure occurs as soon as the maximum load is reached. The results of such tests and corresponding calculations using current material laws (limitation of the maximum concrete strain to 3 to 4×10^{-3} based on the value observed on load controlled cylinder tests) have often led to the incorrect conclusion that columns exhibit little ductility.

Deformation controlled tests on reinforced concrete columns, on the other hand, show a surprisingly high degree of ductility.

Fig. 4 shows a column with a constant normal force, pinned at one end. The base is subjected to an increasing rotation. The rotation has the same effect as if the initially vertical column were subjected to a horizontal displacement of the pinned end.

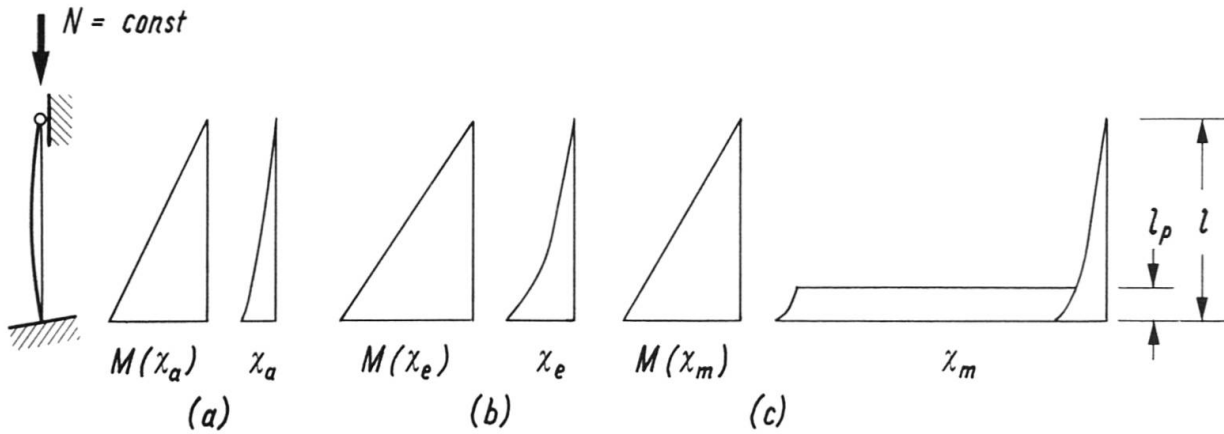

Fig. 4 Moment and Curvature Distributions for Different Deformation States

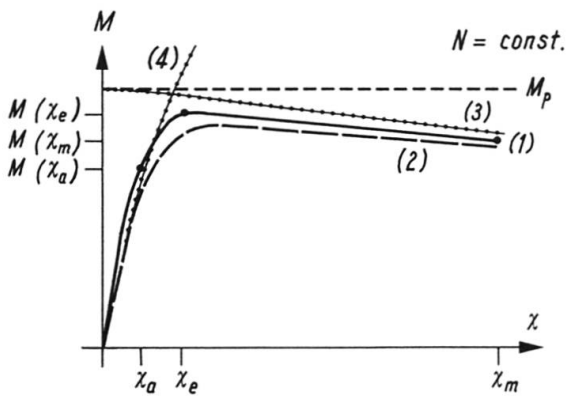
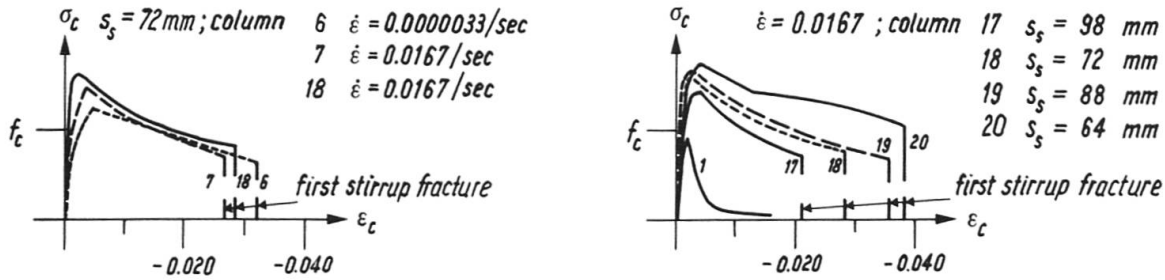

Fig. 5 Moment-Curvature Diagram at the Plastic Hinge

Curvatures and strains can be measured in the zone near the fixed end where a plastic hinge is formed. The moment-curvature diagrams are of the type shown in Fig. 5 (curve 1). The extended horizontal branch of the moment-curvature diagram shows the high ductility of the reinforced concrete column. The strains on the compression face of the column are around 4 to 5×10^{-3} when the column reaches the maximum flexural resistance. Strains between 9 to 16×10^{-3} have been measured in tests when failure occurred because of buckling of the longitudinal reinforcement [1]. The columns were provided with minimum shear reinforcement, with stirrup spacings equal to the column depth.

Other tests [2] show that even higher values of 20 to 30×10^{-3} and more can be reached (see Fig. 6) if in the region of the plastic hinges the stirrups (diameters 8 , 10 , or 12 mm) are closely spaced (50 to 100 mm).



(a) Core concrete stress-strain curves of concentrically loaded columns under two different strain rates

(b) Core concrete stress-strain curves of eccentrically loaded columns of different stirrup spacings (curve 1: unreinforced column)

Fig. 6 Stress-Strain Curves of Confined Concrete (from [2])

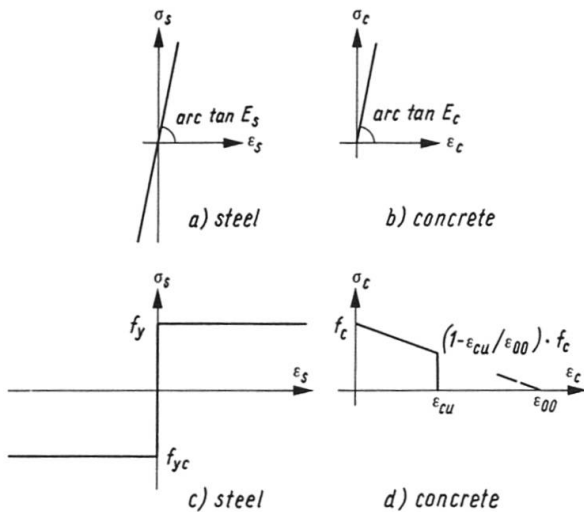

The elastic-plastic behaviour of a column under imposed deformations can be analysed using nonlinear computer programs (curve 2 in Fig.5) or using analytical methods (curve 3 and 4 in Fig. 5) as shown in [3] and [4], using simple material laws (Fig. 7).

Fig. 7 Elastic (a/b) and Plastic (c/d) Material Laws

Fig. 4 shows the curvature distribution over the column length for different deformation states. Moment M and curvature χ increase with increasing rotation of the column base until the maximum flexural resistance is reached. The column then starts to form a plastic hinge. Tests show that plastic hinges develop over a length l_p of 0.5 to 2.0 times the column depth h . The length depends on the moment gradient and therefore on the shear force (see [5]). The curvature increases only in the plastic hinge after the maximum flexural resistance has been reached. The curvature in the elastic zone of the column decreases with the decrease of the moment in the plastic hinge.

The normal force N has reached its maximum eccentricity at the column base when the maximum moment of resistance has been reached (Fig. 8b). Thereafter the nor-

mal force centres itself in order to maintain equilibrium. The first order moment M_1 , which is equal to the normal force times the eccentricity of the normal force with respect to the undeformed (vertical) column axis, becomes smaller after the maximum flexural resistance has been reached. The second order moment M_2 , which is equal to the normal force times the deflection of the column axis, is continuing to increase. The loss in the concrete force due to the diminishing concrete resistance is transferred onto the steel reinforcement. The first order moment is equal to zero when the normal force at the column base is completely centred (Fig. 8c). The remaining resistance in the plastic hinge has to balance the second order moment at this stage. Further rotation of the column base would cause the normal force to move to the other half of the cross section at the column base (Fig. 8d). This additional rotation is in general very small and can be neglected because no further transfer of force from the concrete to the reinforcement is possible.

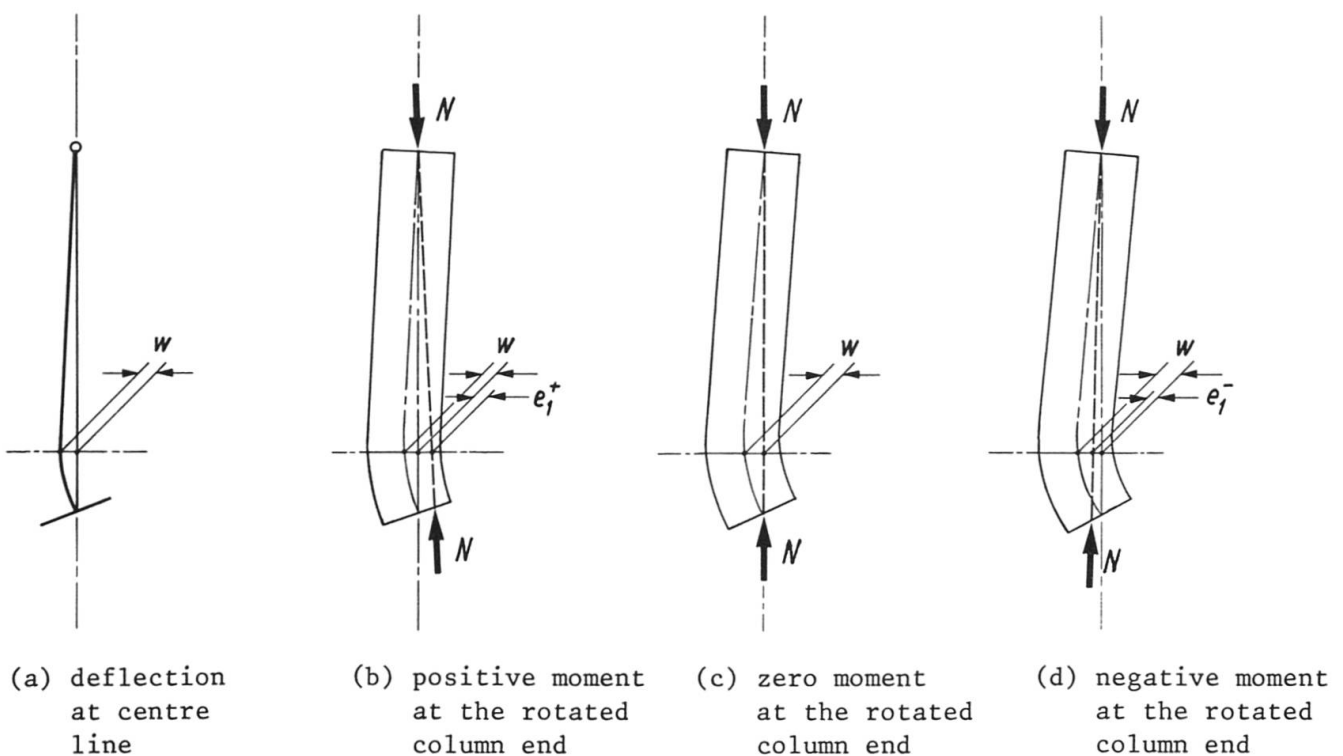

Fig. 8 Position of the Normal Force with Increasing Plastic Rotation of the Column End

However for a column in a frame which develops the maximum moment at midspan, case A, the load capacity is reached as soon as the maximum flexural resistance is reached at the column midspan (see test results of [6]). Only a reduction of the frame loads would allow a decrease of the column end moments so that a plastic hinge could develop at midspan. Deformation case A does not occur in bridge columns or edge columns of buildings. It is normally not governing the design of interior columns in buildings since relatively small loads result from a checkerboard load pattern on the beams.



4. LIMIT CURVATURES

4.1 Admissible Limit Curvature

Crack widths have to be reasonably small and no concrete spalling should occur in a column under service conditions. A limitation of the steel and concrete strain allows a simple way of estimating the admissible mean curvature of a column.

Large strains in the reinforcement bars cause excessive crack widths. Many codes of practice recommend admissible stresses in the steel bars equivalent to about half of the yield strain, approximately 1×10^{-3} . Tests on reinforced concrete elements under pure tension [7] indicate that the admissible average strain for steel bars lies somewhere between 1 to 1.5×10^{-3} . The maximum crack width at these strains were smaller than 0.4 mm in the elements which had sufficient reinforcement ($\rho_{\text{tot}} \cdot f_y / f_c \geq 0.1$ to 0.12). Comparisons with column tests [8] show that $0.55 \cdot \epsilon_y = 1.1 \times 10^{-3}$ can be taken as a safe limit. Those columns which have reached an average strain in the steel bars of 1 to 1.1×10^{-3} had a maximum crack width which did not exceed 0.3 mm. The CEB MANUAL [9] recommends that crack widths should not exceed 0.2 to 0.4 mm.

Concrete spalling can appear in a column when the strain in the extreme fibre exceeds the following values. Short term tests on concrete columns without reinforcement and on reinforced concrete columns [2] show that the concrete cover starts to spall when the strain in the extreme fibre reaches 4 to 5×10^{-3} . Larger strains can be reached with slow load application. The allowable compressive strain of the extreme fibre is assumed to be 2×10^{-3} at the time of load application t_0 . Due to creep the allowable strain is increased to $(1 + \varphi_n) \cdot 2 \times 10^{-3}$ for the time t_∞ . φ_n is the creep coefficient (e.g. $\varphi_n = 2.5$).

Fig. 9 shows possible strain diagrams which define the points in Fig. 10.

Fig. 10 gives for two different cross sections the admissible limit curvature as a function of the normal force ratio N/N_p for the time t_0 and t_∞ . N_p is defined as

$$N_p = A_c \cdot f_c + A_s \cdot f_y, \quad (4.1)$$

where A_c is equal to the section area of the column and $A_s = \rho_{\text{tot}} \cdot A_c$ is equal to the steel area. f_c is the concrete strength and f_y is the steel strength.

Fig. 10 shows that the limit curvatures do not depend greatly on the amount of reinforcement. Fig. 10 also shows that in the case of sustained loading the maximum curvature in a column with a small normal force has to be significantly smaller at the time of load application t_0 than the corresponding admissible limit curvature, as creep increases the curvature with time by a factor of 2.5. Therefore the curvature in the column at time t_∞ is governing.

Table 1 gives admissible limit curvatures for rectangular cross sections, $\psi = 0.6$ to 1.0 (ψ is the ratio of the distance between the longitudinal reinforcement of opposite faces and the column depth, h). They will be used for the estimation of the admissible limit angles at the serviceability limit state.

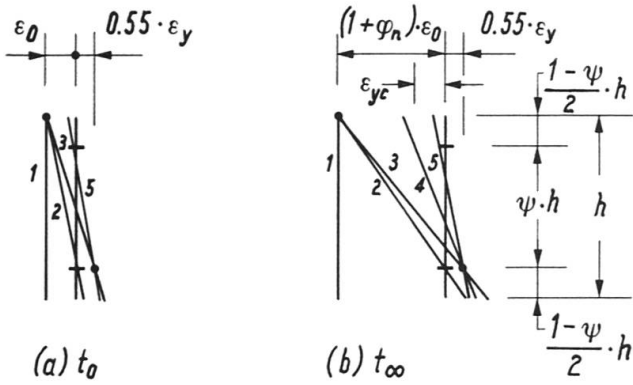

Fig. 9 Strain Diagrams for the Time t_0 and t_∞

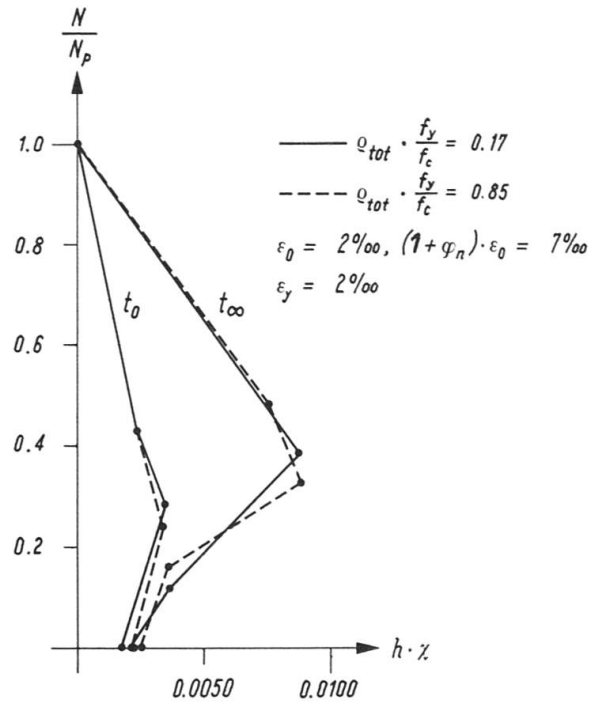

Fig. 10 Admissible Limit Curvatures for Cross Sections with $\rho_{tot} \cdot f_y / f_c = 0.17$ and 0.85 respectively; $\psi = 0.85$

N/N_P	$h \cdot \chi_a(t_0)$	$h \cdot \chi_a(t_\infty)$	$h \cdot \chi_e(t_0)$	$h \cdot \chi_e(t_\infty)$
0 ÷ 0.05	0.0010	0.0020	0.0035	0.0045
0.05 ÷ 0.1	0.0015	0.0030	0.0040	0.0055
0.1 ÷ 0.2	0.0020	0.0040	0.0045	0.0065
0.2 ÷ 0.4	0.0025	0.0050	0.0050	0.0075
0.4 ÷ 0.5	0.0020	0.0050	0.0045	0.0075
0.5 ÷ 0.6	0.0015	0.0040	0.0040	0.0065
0.6 ÷ 0.7	0.0010	0.0030	0.0035	0.0055
0.7 ÷ 0.8	0.0005	0.0015	0.0015	0.0025

Table 1 Admissible and Plastic Limit Curvatures for the Time t_0 and t_∞



4.2 Plastic Limit Curvature

A parameter study [3] using elastic material laws has been made to estimate the curvature when the maximum bending resistance is reached. The curvature was termed plastic limit curvature χ_e . The index e has been used because elastic material laws have been used to define the curvature. Table 1 shows the different values for $h \cdot \chi_e$ as a function of the normal force ratio N/N_p .

4.3 Maximum Limit Curvature

Tests [2] show that large strains (20×10^{-3} and more) can be reached in the core concrete of reinforced concrete columns with closely spaced stirrups such that no buckling of the longitudinal bars and practically no loss in the concrete resistance will occur. However, relatively small concrete strains (4 to 5×10^{-3}) are sufficient to cause spalling of the concrete cover. The following assumption are hence made:

The maximum strain which is possible in the core concrete and in the longitudinal reinforcement is assumed to be 20×10^{-3} , 10 times the steel yield strain $\epsilon_{yc} = 2 \times 10^{-3}$. The (dimensionless) maximum limit curvature is assumed to be $h \cdot \chi_m = 0.02/\psi$. (4.2)

It is further assumed that the column loses its concrete cover after the maximum flexural resistance has been reached and that the resistance of the column with no concrete cover remains thereafter constant.

The strains in the reinforcement bars on the compression face lie between 0 and 20×10^{-3} when the maximum limit curvature is reached, depending on the applied normal force. A column with a very small or no normal force may reach larger curvatures in a plastic hinge as there is no danger of buckling of the reinforcement bars. The proposed limit is nevertheless considered to be sufficiently large to allow large plastic rotations.

5. LIMIT ANGLES

5.1 Admissible Limit Angle

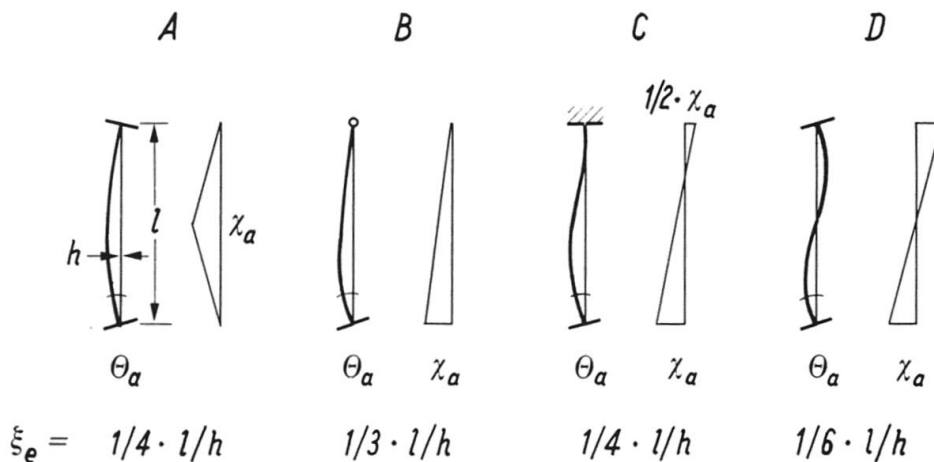

Fig. 11 Admissible Limit Angles:
Curvature Distributions and Coefficients ξ_e

Fig. 11 shows the assumed curvature diagrams for the calculation of the admissible limit angles. A linear curvature distribution is assumed. Local curvature variations due to cracking are ignored as well as the increase of the curvature due to the deformation of the column (2nd order effect). The admissible angle can be expressed as:

$$\theta_a = \xi_e \cdot h \cdot \chi_a. \quad (5.1)$$

The coefficient ξ_e depends on the deformation case and on the slenderness ratio l/h of the column. Table 1 gives the values for the curvature $h \cdot \chi_a$.

The curvature distribution of deformation case A has been assumed to be triangular in order not to overestimate the limit angle as the maximum moment is reached at midspan.

5.2 Plastic Limit Angle

The curvature distributions of the columns which have reached the maximum flexural resistance have been assumed to be similar to those shown in Fig. 11. The plastic limit angle is equal to

$$\theta_e = \xi_e \cdot h \cdot \chi_e. \quad (5.2)$$

5.3 Maximum Limit Angle

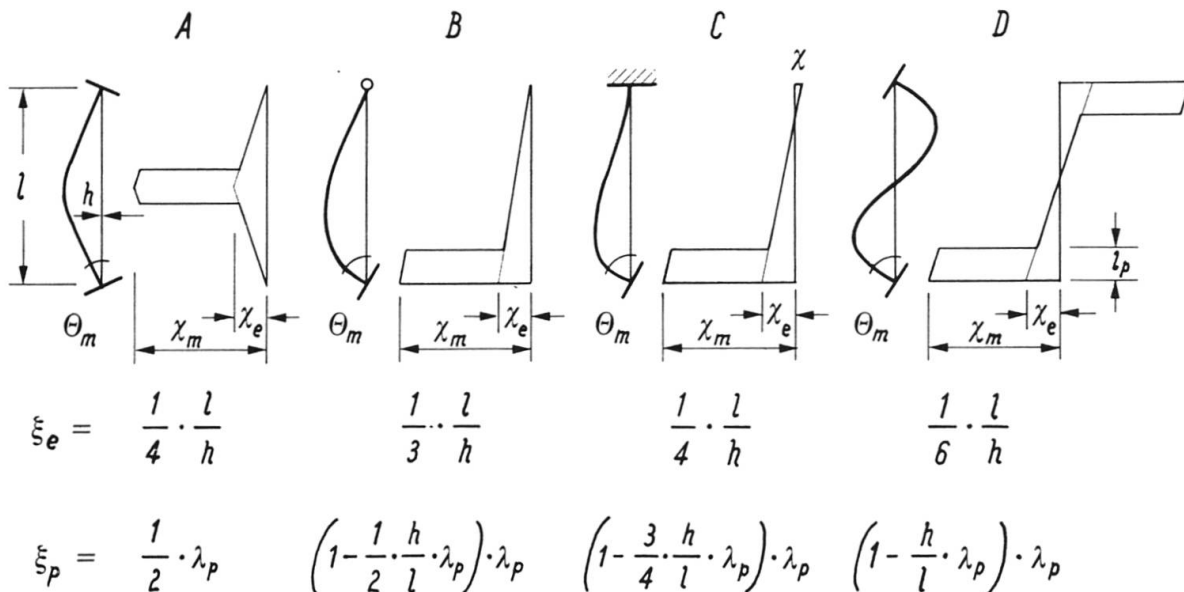

Fig. 12 Maximum Limit Angles:
Curvature Distributions and Coefficients ξ_e , ξ_p

Fig. 12 shows the assumed curvature distributions for the calculation of the maximum limit angles. The maximum limit angle is equal to

$$\theta_m = \xi_e \cdot h \cdot \chi_e + \xi_p \cdot (h \cdot \chi_m - h \cdot \chi_e). \quad (5.3)$$

The coefficients ξ_e and ξ_p are given in Fig. 12, the plastic curvature $h \cdot \chi_e$ is given in Table 1. Eq. (4.2) gives the maximum limit curvature $h \cdot \chi_m$. The value



λ_p in coefficient ξ_p is defined as

$$\lambda_p = \ell_p / h, \tag{5.4}$$

with ℓ_p equal the length of the plastic hinge. Comparisons between measured deformations on test columns and theoretical results where $\ell_p = h$ has been used in the calculations show good agreement [1,3]. $\ell_p = 0.5 \cdot h$, h or $2 \cdot h$ respectively can be used in the estimation of the maximum limit angle provided that the column has closely spaced stirrups over h , $1.5 \cdot h$ or $2.5 \cdot h$ respectively in the zone where the plastic hinge will develop.

In case A, it is only possible for an isolated column in a deformation controlled test to develop a plastic hinge at midspan and to reach the maximum limit angle. A frame column can not reach the maximum limit angle since instability occurs as soon as the maximum flexural resistance is reached at the column midspan (see chapter 3). The maximum limit angle for case A is equal to the plastic limit angle.

6. SLENDERNESS CONTROL

The second order effects have to be checked for columns with high normal forces and high slendernesses. For derivation of the following relationships and results reference is made to [3].

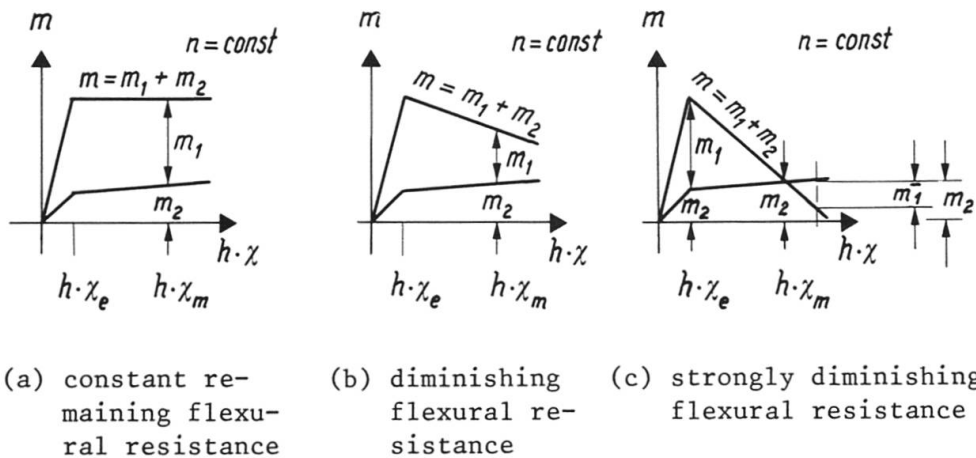

Fig. 13 Possible Moment-Curvature Relationships

Fig. 13 shows schematically three possible moment-curvature relationships for a column with a constant normal force. The actual moment-curvature relationship depends on the applied normal force and on the material behaviour of the steel and concrete.

Fig. 14 shows also schematically the moment and curvature distributions over the column length for the four cases defined in Fig. 3. Two different deformation states are shown, the state at which the maximum flexural resistance is reached (Fig. 14 a to c) and the state at which the maximum limit curvature is reached in the plastic hinge (Fig. 14 d to k). Three different moment and curvature distributions are shown for that state. They are based on the three possible moment-curvature relationships shown in Fig. 13.

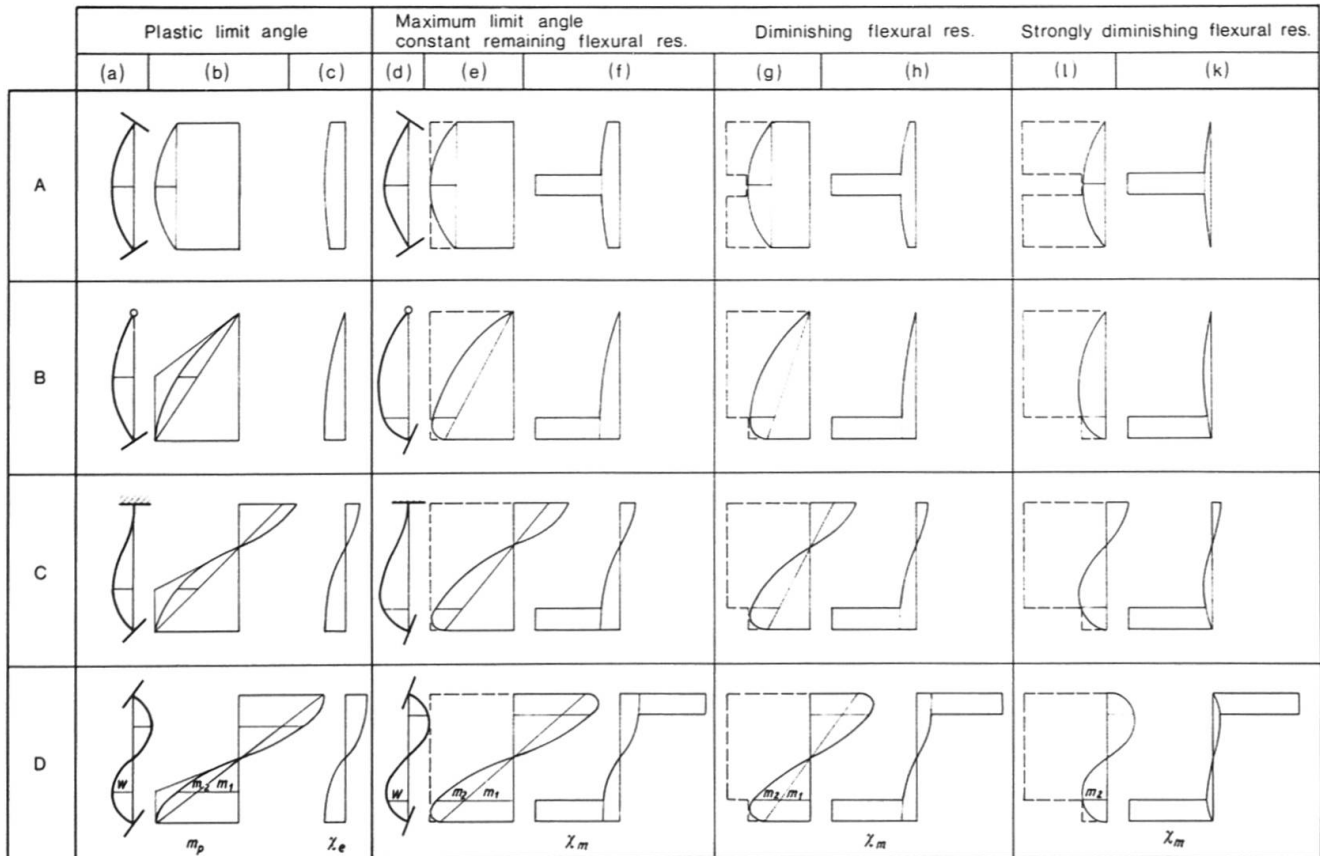

Fig. 14 Moment and Curvature Distributions for the Deformation Cases A, B, C and D

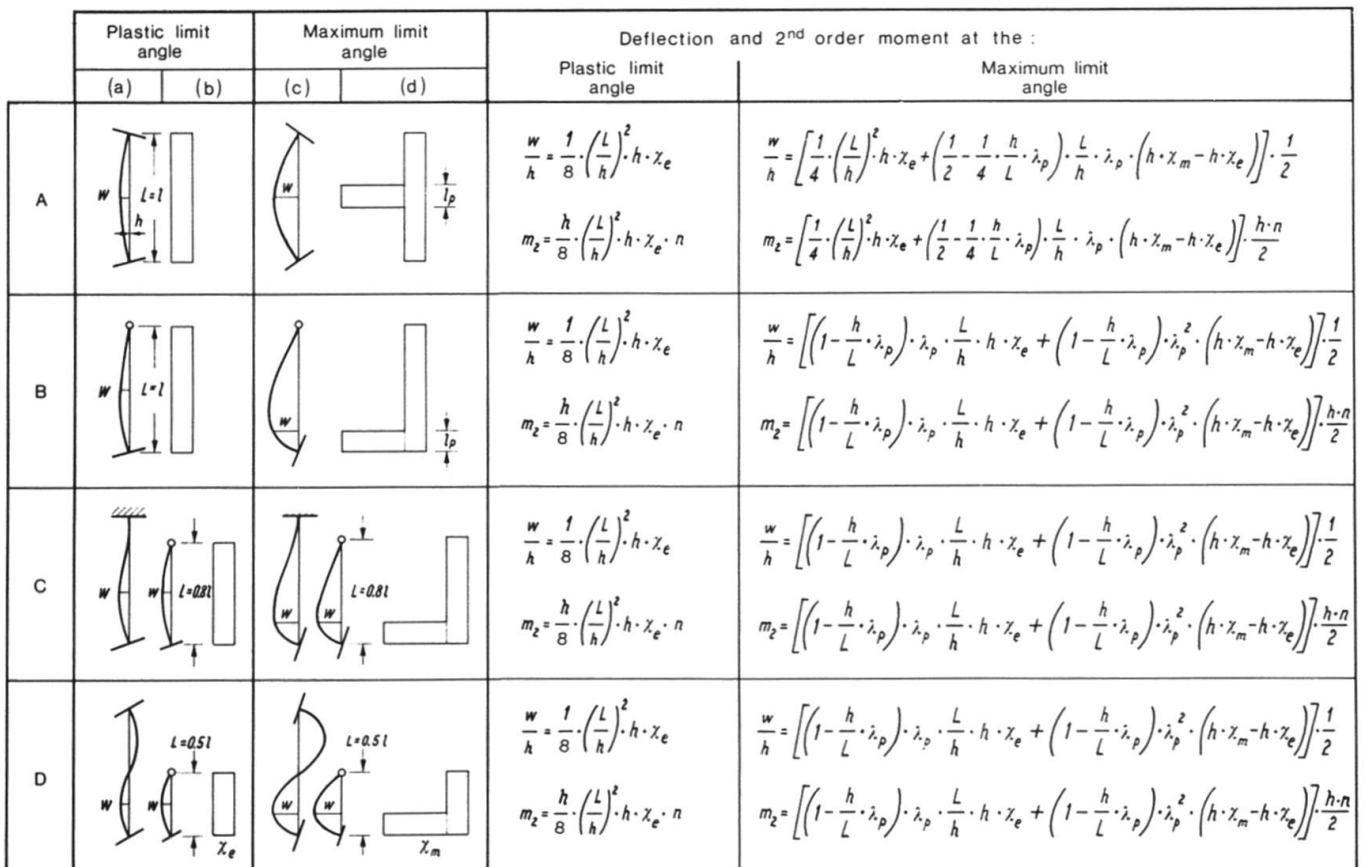

Fig. 15 Curvature Distributions and Formulae for the Calculation of the 2nd Order Moment



In case A, instability occurs in a frame columns as soon as the moment at mid-span reaches the maximum flexural resistance:

$$M_1 + M_2(\chi_e) = M_p. \quad (6.1)$$

M_1 is the first order moment (end moment), $M_2(\chi_e)$ is the second order moment and M_p is the maximum flexural resistance. The ultimate limit state is verified in case A, if eq. (6.1) is fulfilled: the imposed angle under ultimate load is equal to the plastic limit angle ($\varphi_r = \Theta_e$).

The moment distribution in Fig. 14b for case B, C and D corresponds to the extreme moment distribution for which the column still forms a plastic hinge at the rotated end: the moment diagram, for which a parabolic shape has been assumed, has a vertical tangent at the column end where the maximum flexural resistance is reached. Fig. 14b shows that the maximum second order moment has to be smaller than one quarter of the flexural resistance if the column should reach its maximum resistance at the rotated column end in the cases B, C or D:

$$M_2(\chi_e) \leq M_p/4. \quad (6.2)$$

The second order moment has to be smaller than the remaining flexural resistance after the formation of the plastic hinge in case B, C or D (see Fig. 14 e/g/i):

$$M_2(\chi_m) \leq M(\chi_m) \leq M_p, \quad (6.3)$$

with M the remaining flexural resistance.

A safe limit value can be found for the second order moment if a rectangular curvature distribution (Fig. 15) is assumed. The second order moments calculated in this way are slightly too large and hence lead to a conservative design.

Deformation case D is equal to deformation case B, if one takes $0.5 \cdot \ell$ instead of ℓ . Deformation case C lies somewhere inbetween these two cases. Deformation case C can approximately be treated as case B if one takes $0.8 \cdot \ell$ instead of ℓ . The formulae for the deflections and second order moments are given in Fig. 15. L depends on the deformation case and can be ℓ , $0.8 \cdot \ell$ or $0.5 \cdot \ell$.

A control of the second order influence is not necessary if the slenderness ratio does not exceed a certain value. Limit values for this slenderness ratio can be found by expressing eq. (6.1), (6.2) or (6.3) as a function of the deflection. For example, eq. (6.1) can be written as

$$\frac{1}{8} \cdot \left(\frac{L}{h}\right)^2 \cdot h \cdot \chi_e \leq \frac{M_p - M_1}{M_p} \cdot \frac{w_{all}}{h}. \quad (6.4)$$

The allowable deflections (w_{all}) have been determined [3] as a function of the normal force ratio $N/\psi \cdot N_p$ using M-N- ρ diagrams. The M-N- ρ diagram for cross sections with no cover concrete has been used in order to make a conservative estimation. For the plastic limit curvature the value $h \cdot \chi_e = 0.0075$ has been used.

Fig. 16a and b give the derived lower limit values for the slenderness ratio $\lambda = \sqrt{12} \cdot \ell/h$ as a function of the normal force ratio $N/\psi \cdot N_p$ for columns with rectangular cross sections for which eq. (6.1), (6.2) and (6.3) respectively are satisfied. The influence of the second order effect, eq. (6.1), (6.2) and (6.3) respectively, need not be considered for columns with a slenderness ratio and a normal force ratio which lies within the allowable range for the given deformation case (see Fig. 16).

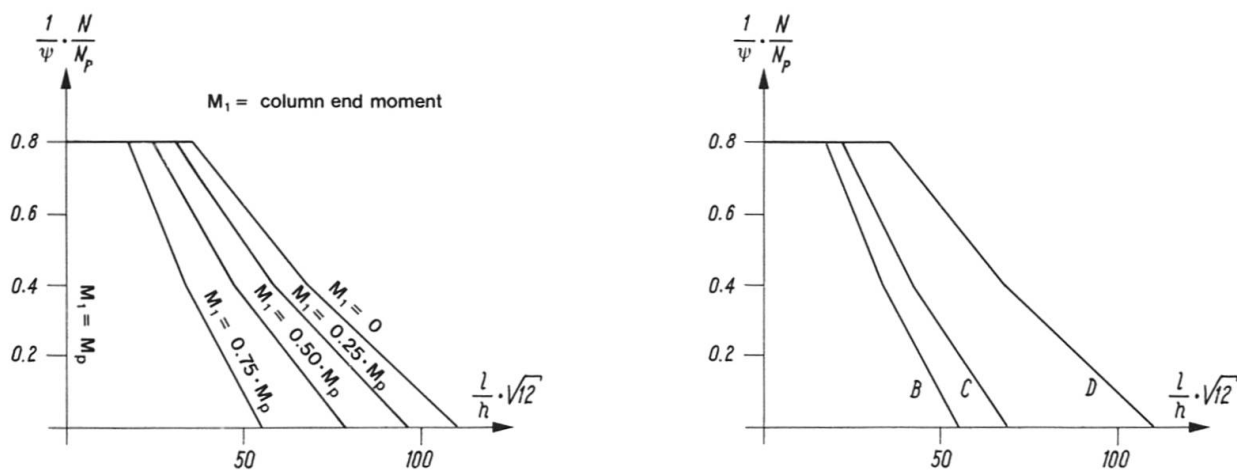

(a) For deformation case A

(b) For deformation cases B, C and D

Fig. 16 Limit values of slenderness ratios for which eq. (6.1), (6.2) or (6.3) [second order influence] need not be checked. Valid for rectangular cross sections with equal and opposite reinforcement layers; $\rho_{\text{tot}} \cdot f_y / f_c \geq 0.15$, $0.6 \leq \psi \leq 1.0$.

7. IMPOSED ANGLES

7.1 Imposed Angle at Serviceability Limit State

The imposed angle due to an eccentric load may be estimated with the displacement method. The angle (see Fig. 17) is equal to

$$\vartheta_{\ell} = M_f / \Sigma S. \quad (7.1)$$

An elastic behaviour is assumed. M_f is the fixed end moment at the node. ΣS is the sum of the stiffnesses of the individual members. The stiffness of an individual member (with the length ℓ) is $S = \iota \cdot E \cdot I / \ell$, ι is equal to 3 or 4 depending on the deformation case. I is the moment of inertia of the concrete cross section (in the case of flat slabs the equivalent beam width is equal to the slab width). E is the modulus of elasticity of concrete, taken as

$$E = f_c / 0.002 \quad \text{for } t_0, \quad (7.2)$$

and

$$E = f_c / 0.002 \cdot (1 + \varphi_n) \quad \text{for } t_{\infty}. \quad (7.3)$$

The relatively low value for the modulus of elasticity takes into account the loss of rigidity due to crack formation and initial creep. The influence of the normal force on the stiffness is neglected.

The imposed angle due to a change in length of the beam due to shrinkage is equal to

$$\vartheta_{\text{cs}} = \delta_{\text{cs}} / \ell = \Delta \epsilon_{\text{cs}} \cdot \ell_{\text{df}} / \ell. \quad (7.4)$$

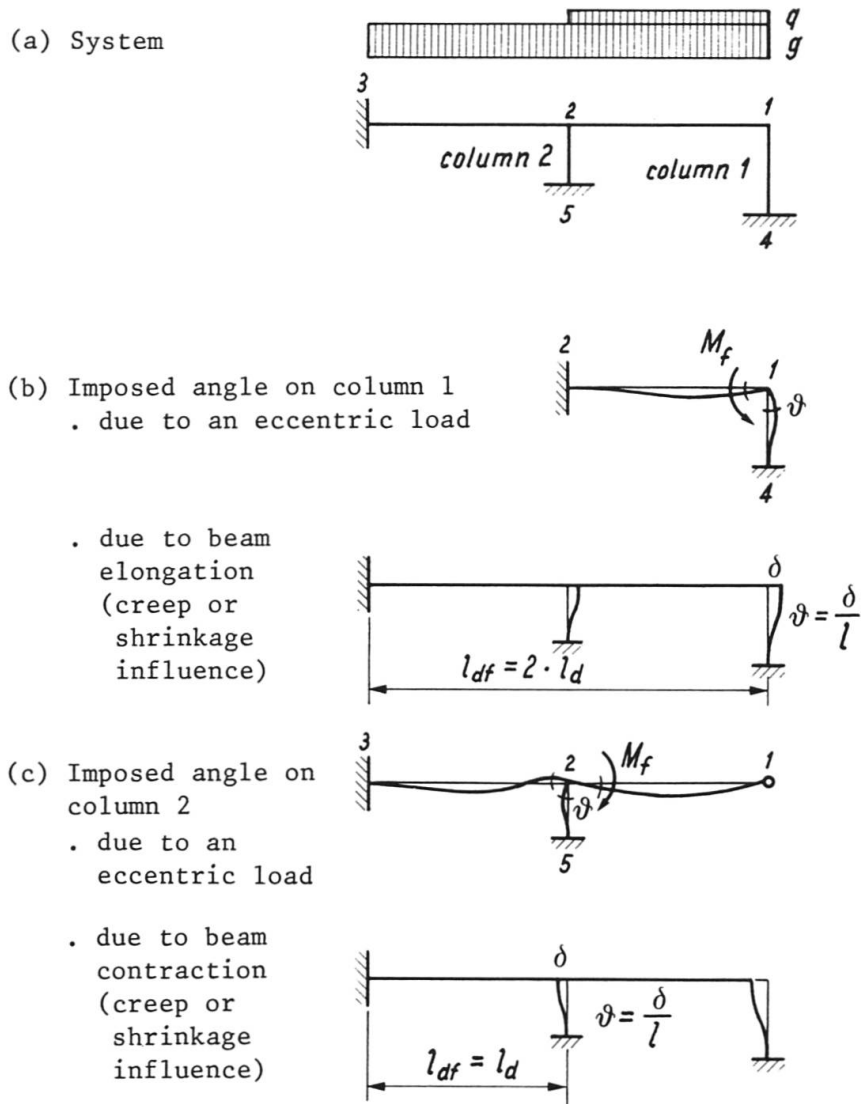

Fig. 17 Serviceability Limit State

δ_{CS} is the horizontal displacement, l the column length and l_{df} the horizontal distance between the column and the fixed point of the beam. $\Delta\epsilon_{CS}$ is the differential shrinkage strain. $\Delta\epsilon_{CS}$ is assumed to be equal to $\epsilon_{CS}/3$ for columns in buildings and is equal to ϵ_{CS} for columns and bridge piers fixed rigidly to the foundations.

The imposed angle due to a change in length of the beam due to temperature is equal to

$$\vartheta_t = \delta_t / l = \alpha_t \cdot \Delta T \cdot l_{df} / l. \tag{7.5}$$

α_t is the coefficient of thermal expansion for the concrete and steel, ΔT is the temperature change.

7.2 Imposed Angle at Ultimate Limit State

Critical beam mechanisms for columns are those mechanisms which lead to plastic hinges in the columns (Fig. 18). A large deformation capacity is required for these columns. The columns need a much smaller deformation capacity if the mechanism produces plastic hinges in the beam only.

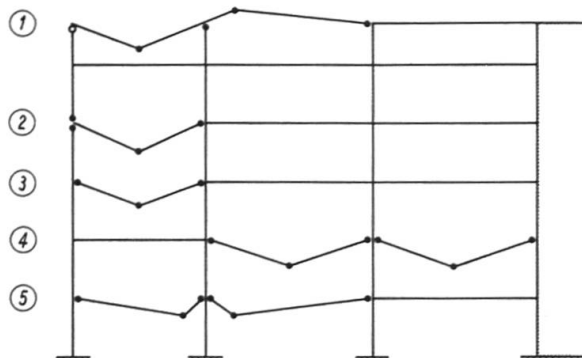

Fig. 18 Ultimate Limit State

Different mechanisms:

- plastic hinge in an interior column : 1
- plastic hinges in edge columns : 2
- plastic hinges in the slab only : 3,4,5

Generally no plastic hinges develop in interior columns. Sufficiently long reinforcement bars in the beam over the interior columns make it impossible for a mechanism to occur over several spans. The dead load is generally higher than the live load so that even the extreme load case with the live load on just one side of a column will lead to a single span mechanism.

Normally only the columns on the edge of a building are critical, and in particular those of the top floor. A plastic hinge appears in an edge column if the flexural resistance of the edge column is smaller than the flexural resistance of the beam. A simple way to prevent the formation of a plastic hinge in an edge column is the choice of a column with a resistance which is higher than the resistance of the beam.

In the case of flat slabs the flexural resistance of interior spans is determined with the total width of the slab. At edge columns only a limited zone of the slab around an edge column helps to restrain the column against bending. The width of this zone may be assumed to be the width of the column plus twice the slab thickness on each side of the column.

Fig. 19a shows a failure mechanism with a plastic hinge in the edge column in which only the plastic deformations are shown. The first plastic hinge usually appears in the column, and a second follows in the beam at the fixed end. The last plastic hinge is formed at midspan.

Fig. 19b shows the deflected form of the beam at the onset of the failure mechanism, with the formation of the last plastic hinge at midspan. The moment diagram is given in Fig. 19c. The rotation angle of the beam over the support is equal to the imposed angle on the column. It will be shown that the angle can be estimated when making the following assumptions :

The contribution to the deformation of the curvatures in the plastic hinge at the right end of the beam (Fig. 19d) is neglected (the length of the plastic hinge is small compared to the beam length). The curvature diagram is continuous and parabolic. The small negative curvatures at the left end of the beam are neglected.



The angle can now be calculated with the principle of virtual force:

$$\vartheta_r = \int_0^{l_d} \chi_d \cdot \bar{M} \cdot dx = (\chi_{de}^+ + \chi_{de}^- / 2) \cdot l_d / 3 - \chi_{de}^- \cdot l_d / 6 = h_d \cdot \chi_{de} \cdot l_d / 3 \cdot h_d \quad (7.6)$$

$h_d \cdot \chi_{de}$ is equal to the curvature in the beam when the plastic moment is reached. Table 1 gives the curvature for time t_0 and t_∞ for $N = 0$. The imposed angle is at time

$$t_0 : \vartheta_r = 0.0012 \cdot l_d / h_d, \quad (7.7)$$

and

$$t_\infty : \vartheta_r = 0.0015 \cdot l_d / h_d. \quad (7.8)$$

The imposed angle at ultimate limit state depends only on the beam slenderness ratio.

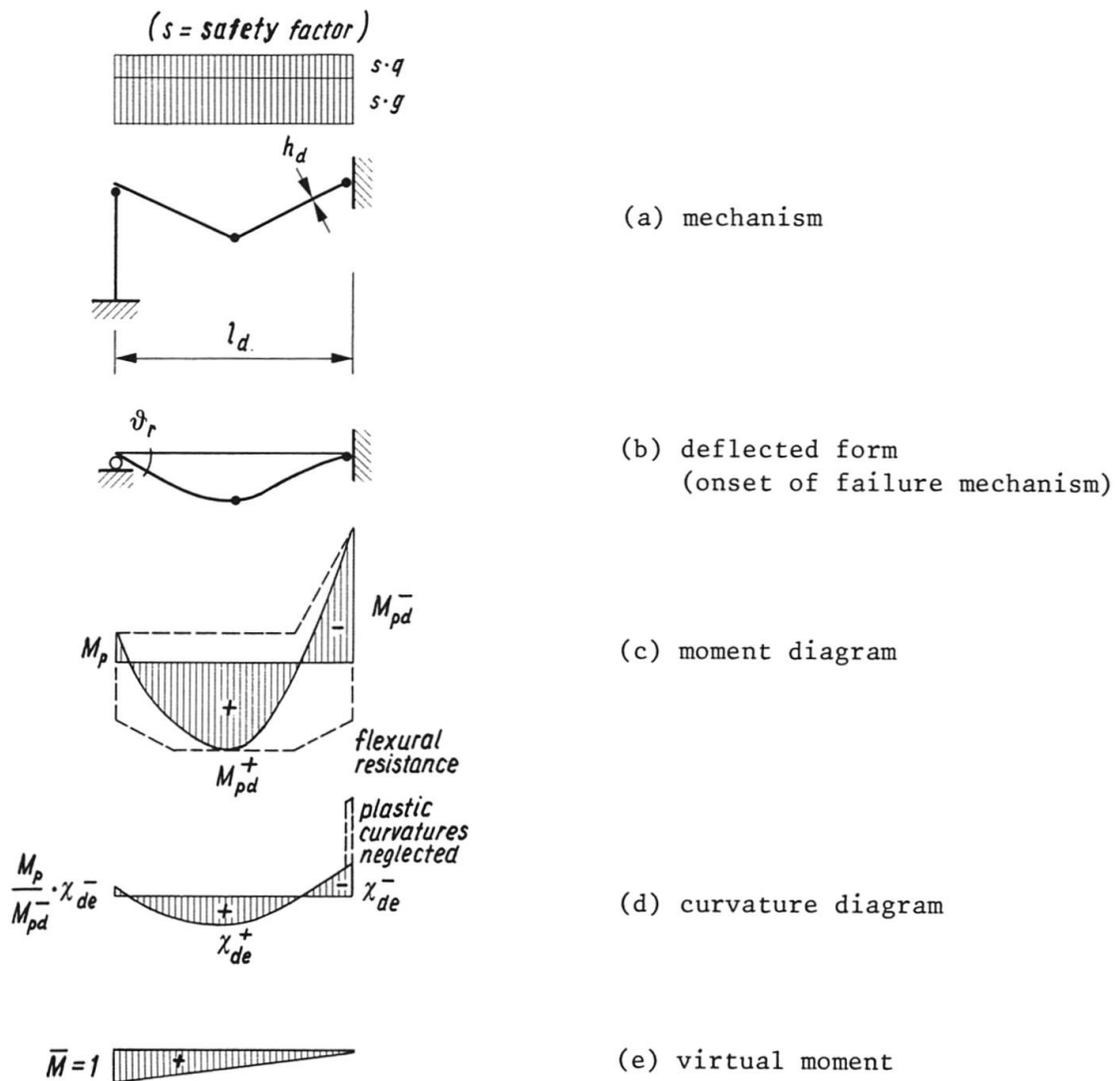

Fig. 19 Mechanism with a Plastic Hinge in the Edge Column

8. CONCLUSIONS

Braced reinforced concrete columns in buildings and bridges are primarily loaded by normal forces. Bending occurs through imposed deformations. In current design procedures, such a column is usually isolated from the rest of the structure. The nonlinear interaction of the column with the structure is neglected. Actually if the maximum flexural resistance due to external loads is reached at a column end a plastic hinge will simply be formed which allows further large deformations to occur. The normal force starts to centre itself at the rotated column end after the maximum flexural resistance has been reached. The column fails when the deflection within the plastic hinge produces a moment which becomes equal to the remaining resistance. The imposed end deformation and the applied normal force are important for the design of the column and not the maximum flexural resistance.

It is proposed to design these columns by considering the normal forces and the imposed end deformations. The serviceability and the ultimate limit states of the columns are verified by comparing the estimated imposed angles at the column ends with the limit angles of the columns. The latter can be estimated from the limit strains and curvatures. Results from tests on reinforced concrete columns under imposed deformations and theoretical considerations make it possible to define reasonable limits for the possible strains and curvatures:

A compression strain of 2×10^{-3} can be reached at time t_0 and 7×10^{-3} , after creep, at time t_∞ without any concrete spalling. Average strains of about 1.1×10^{-3} in tension reinforcement bars lead to small, permissible cracks. The admissible limit curvature depends on the level of the applied normal force and is limited by the two above mentioned strain limits.

A strain of 20×10^{-3} and more can be reached in the compression reinforcement bars and in the core of reinforced concrete columns with closely spaced (50 to 100 mm) stirrups (diameter 8 to 12 mm) without buckling of the reinforcement bars nor any significant loss in the resistance of the core concrete. The maximum limit curvature can be fixed to 20×10^{-3} divided by the distance between the longitudinal reinforcement of opposite faces.

The proposed method can serve as a basis for a practical design procedure for reinforced concrete columns under imposed end deformations.

9. ACKNOWLEDGEMENT

This paper was developed in the course of a research project on reinforced concrete columns carried out at the Swiss Federal Institute of Technology, Lausanne (see [3], [8], [10]). The author wishes to express his thanks to Prof. R. Favre, who supervised the project.

10. REFERENCES

- [1] FORD J.S., CHANG D.C. and BREEN J.E., Behavior of Concrete Columns Under Controlled Lateral Deformation, ACI Journal, Title no.78-1, Jan-Feb 1981.
- [2] SCOTT B.D., PARK R. and PRIESTLEY M.J.N., Stress-Strain Behavior of Concrete Confined by Overlapping Hopps at Low and High Strain Rates, ACI Journal, Title no.79-2, Jan-Feb 1982.
- [3] THURLIMANN C., Bemessung von Stahlbetonstützen unter Zwangsverformungen (Design of R.C. Columns under Imposed Deformations), PhD Dissertation, Swiss Federal Institute of Technology Lausanne, 1984.



- [4] ROSSI M., Unelastisches Verhalten zyklisch verformter Stahlbetonbalken (Unelastic Behaviour of R.C. Beams Subjected to Cyclic Deformations), PhD Dissertation, Bericht Nr. 125, IBK, Swiss Federal Institute of Technology Zürich 1982, Birkhäuser Verlag Basel · Boston · Stuttgart.
- [5] GRENACHER M., Einfluss von Verschiebungen und verschiedenen Lagerungen auf das Tragverhalten von Stahlbetonstützen (Influence of Deformations and Different Types of Supports on the Load Capacity of R.C. Columns), PhD Dissertation, Bericht Nr. 61, IBK, Swiss Federal Institute of Technology Zürich 1976, Birkhäuser Verlag Basel · Boston · Stuttgart.
- [6] FURLONG R.W., FERGUSON P.M., Tests of Frames with Columns in Single Curvature, Symposium on Reinforced Concrete Columns, SP-13, American Concrete Institute, Detroit 1966.
- [7] JACCOUD J.-P., FRANCOU B., CAMARA J.-M., Armature minimale pour le contrôle de la fissuration, Rapport d'essais, IBAP, Swiss Federal Institute of Technology Lausanne, May 1984.
- [8] NAJDANOVIC D., Vérification de l'état d'utilisation des colonnes en béton armé sous l'effet de déformations imposées de longue durée, PhD Dissertation, Swiss Federal Institute of Technology Lausanne, to be published in 1985.
- [9] CEB MANUAL, Fissuration et déformations, Swiss Federal Institute of Technology Lausanne, 1983.
- [10] FAVRE R., NAJDANOVIC D., SUTER R., THURLIMANN C., A New Design Concept for R.C. Columns in Buildings, Final Report, 12th Congress IABSE Vancouver, 1984.