

Zeitschrift: IABSE reports of the working commissions = Rapports des commissions de travail AIPC = IVBH Berichte der Arbeitskommissionen

Band: 6 (1970)

Artikel: Measurement results on behavior and effect of temperature change on R.C. structure

Autor: Takahashi, Hisao / Nakajima, Yasuo

DOI: <https://doi.org/10.5169/seals-7769>

Nutzungsbedingungen

Die ETH-Bibliothek ist die Anbieterin der digitalisierten Zeitschriften. Sie besitzt keine Urheberrechte an den Zeitschriften und ist nicht verantwortlich für deren Inhalte. Die Rechte liegen in der Regel bei den Herausgebern beziehungsweise den externen Rechteinhabern. [Siehe Rechtliche Hinweise.](#)

Conditions d'utilisation

L'ETH Library est le fournisseur des revues numérisées. Elle ne détient aucun droit d'auteur sur les revues et n'est pas responsable de leur contenu. En règle générale, les droits sont détenus par les éditeurs ou les détenteurs de droits externes. [Voir Informations légales.](#)

Terms of use

The ETH Library is the provider of the digitised journals. It does not own any copyrights to the journals and is not responsible for their content. The rights usually lie with the publishers or the external rights holders. [See Legal notice.](#)

Download PDF: 02.04.2025

ETH-Bibliothek Zürich, E-Periodica, <https://www.e-periodica.ch>

Measurement Results on Behavior and Effect of Temperature Change on R.C. Structure

Résultats des mesures du comportement d'une structure en béton armé, et influence du changement de température

Meßergebnisse über Verhalten und Wirkung von Temperaturwechseln in Stahlbetonbauten

<p>HISAO TAKAHASHI Dr. of Eng. Chief Building Material Sec. Engineering Research Laboratory Ohbayashi-Gumi, Ltd. Japan</p>	<p>YASUO NAKAJIMA Engr. Building Material Sec. Engineering Research Laboratory Ohbayashi-Gumi, Ltd. Japan</p>
---	--

Introduction

This report comprises the results of measurements and analyses of temperature changes and behavior (movement) made on the roof slab and frame of the General Testing Laboratory of Ohbayashi-Gumi Engineering Research Institute.

Construction of the laboratory was completed in December 1965. Measurements of changes in temperature distribution and behavior of this building were commenced in May 1967 and are being continued even now.

At that time the measurement were started, there were frequent occurrences of trouble with waterproofing on roof slabs and judging it of value to conduct investigations on actual building in order to eliminate this trouble, it was decided to carry out the temperature change and behavior measurements described. Although emphasis was laid on measurements at only. The roof slab in the beginning, it was realized that a solution could not be obtained unless the accompanying behavior of the frame was known, then a change was made mid-way in the program to include investigations of the frame.

The Institute is situated at suburbs of Tokyo at lat. $35^{\circ}47' N$ and long. $135^{\circ}03' E$, approximately 40 km northwest from the city center. Photo.1 shows a bird's eye view and Fig. 1 is the layout of the laboratories which is at a location where urbanization has not progressed relatively. As can be seen from these illustrations there is not very much shading by buildings and trees, and especially with regard to the building under observation the sun shines evenly on it with results showing a uniform amount of sunlight on the surface of the roof slab, a condition found extremely good for carrying out measurements.

The building on which measurements are being made is the General Testing Building A in Fig. 1, divided into four sections by expansion joints. Measurements reported herein were performed on the block marked . Briefly described, the building consists of precast concrete curtain walls (SHOCKBETON), floor slab concrete finished with vinyl acetate resin coating and ceilings of plaster board finished with paint.

The roof waterproofing consisted only of a coating about 0.5 mm thick of chlorosulfonated polyethylene (hypalon) which was considerably deteriorated at the time measurements were begun so that concrete was in a condition close to total exposure.

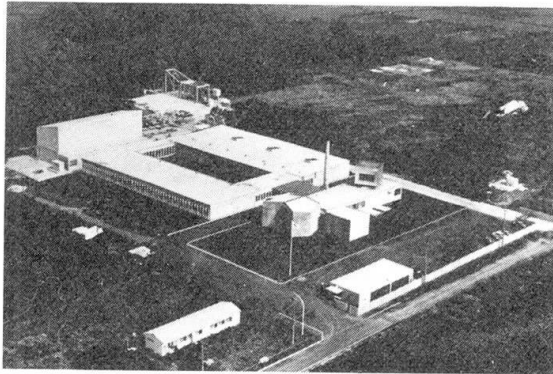

Photo. 1 Bird's-eye view

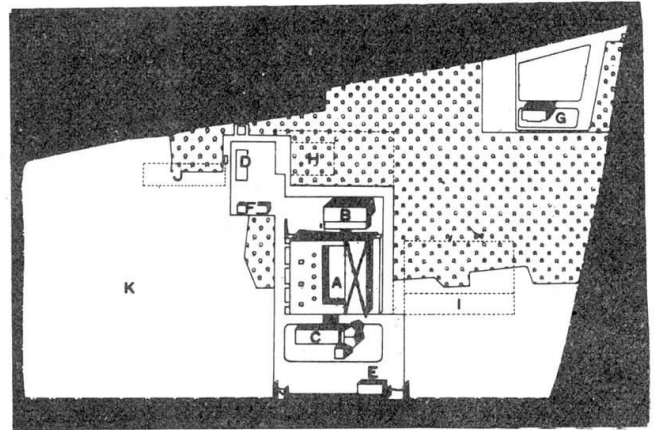

Fig. 1 General layout

- A General testing building
- B Structural strength and vibration testing building
- C Acoustic and air conditioning testing building
- D Multi-purpose testing table
- E Garage and guard's room
- F Construction method & equipment testing room
- G Apartment house for staff families
- H Large scale structure testing building
- I Administration building
- J Workshop
- K Outdoor testing area

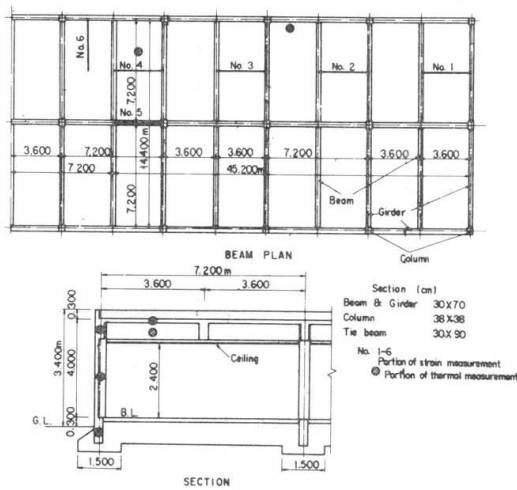

Fig. 2 Beam plan and section.

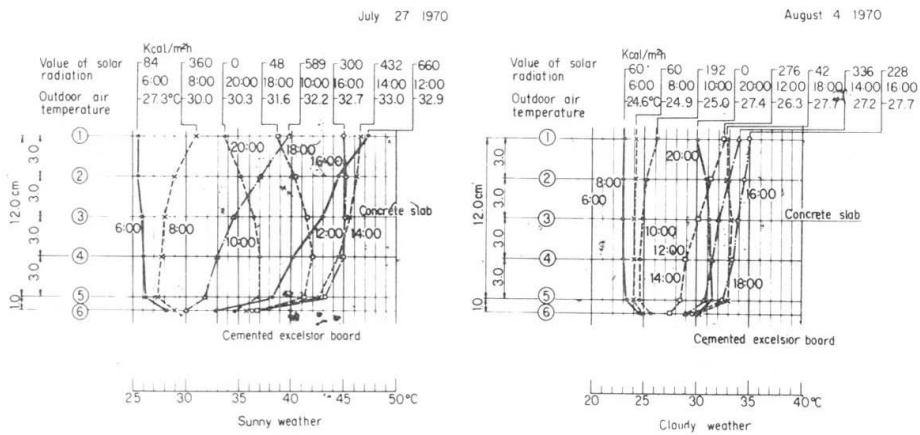
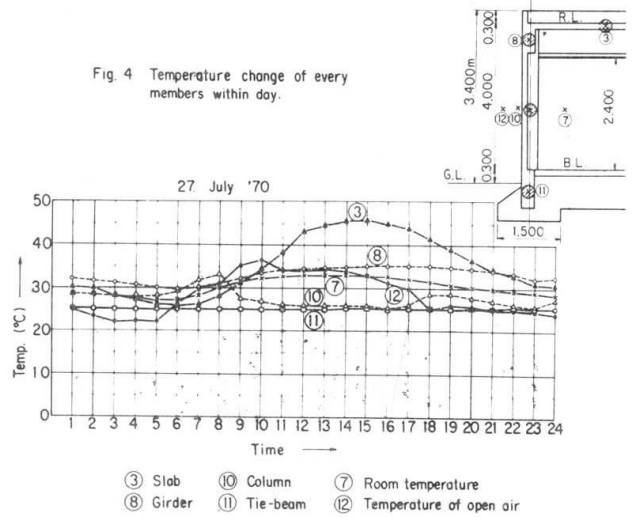

Fig. 3 Temperature change of roof slab with day at every time.

Heating and cooling of the interior are carried out with package type air conditioning units placed at several locations within the building.

Results of Measurements of Temperature Distribution and Behavior

Fig. 2 gives the beam plan and section of the building in which locations of temperature and strain measurements respectively are indicated.

(A) Measurement of temperature distribution change.

(1) Roof slab temperature change within day.

Examples of the conditions of change at the surface and concrete in the roof slab for sunny and cloudy weather are in Fig. 3. Temperature changes are indicated for every two hours, the min. temperature found to occur at around 6 a.m, heat being stored until max. are reached at 2 to 4 p.m. It should be noted that cemented exceliar boards are fixed to the underside of the roof slab of this building.

(2) Temperature changes of roof slab, beam, column and tie-beam within day.

The temperature changes at the centers of the various members are indicated in Fig. 4. In summer according to this figure, tie-beam (11) shows no change while Column (10) to the east side is struck by sunlight from around 5.00 to 6.00 A.M. so that its temperature is raised. From 8 a.m. the temperature drops (approximately 7°C) due to air-conditioning in the interior and is maintained evenly until around the time (5 p.m.) when cooling is shut off after that the temperature begins to rise again. Beam (8) is not affected by cooling, but its temperature difference with tie-beam being approximately 5 to 7°C while the difference with the center of the slab is approximately 10°C.

These temperatures were noted with automatic recorders connected by lead wires to thermocouple and the thermocouple sheet (copper-constantan) embedded in holes drilled into concrete at the various locations indicated in Fig. 3 and Fig. 4.

(B) Measurement of strain change and its results.

The places at which strain change was measured were the 6 locations numbered 1 through 6 in Fig. 2. As can be seen from the beam plan there are beams at the middle of girders in span direction, the intervals being 3.60 m while the spacing between girders are 7.20 m, there being 7 spans. The plan is a rectangle 50.40 m (ridge direction) x 14.40 m (span direction).

Although displacement should be measured for girder span, since it was difficult to obtain 16 fused-quartz glass tubes for 7.20 m long at that time, measurements initiated to made on 3.60 m that is one-half of span.

Details of device of strain measurement are given in Fig. 5. Photo. 2 shows the manner in which this apparatus is installed. In this method, quartz glass tube with a measurement length of 3.60 m is used with other end fixed and another end free, a differential transformer being mounted to the free end through which au-

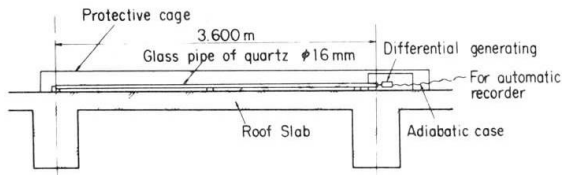

Fig. 5 Device of strain measurement

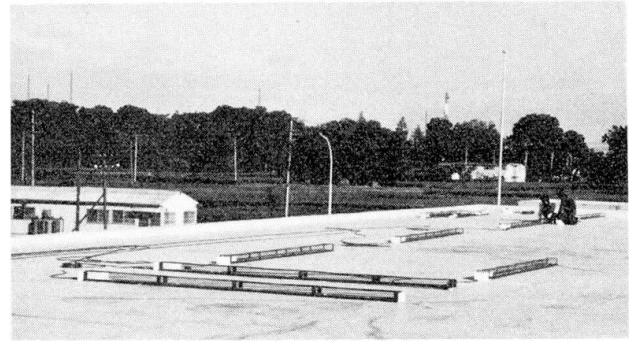

Photo. 2 The whole view of strain measurements

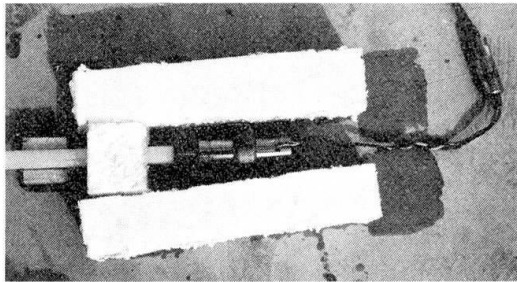

Photo. 3 Insulating case and differential transformer

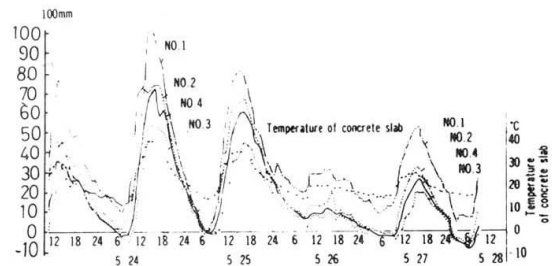

Fig. 6 Strain changes between girders. 24 ~ 28 MAY, 1968

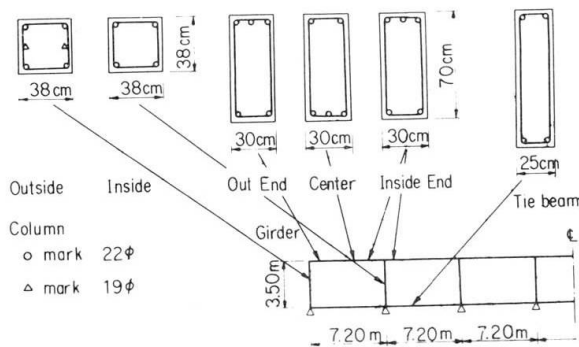

Fig. 9 Section List.

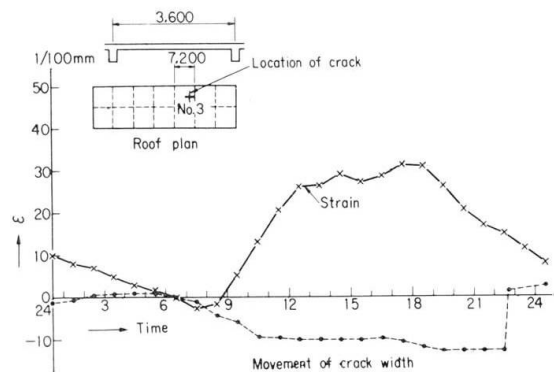

Fig. 8 Behavior on strain of bay between girders and width of crack.

Table 1. Typical values (dI & ΔI) at 6:00 and 16:00 o'clock on the every season (1968~1969)

Season Location	SPRING (1968) (25 MAY)		SUMMER (1968) (1 AUG.)		AUTUMN (1968) (1 NOV.)		WINTER (1969) (15 JAN.)					
	dI mm	ΔI mm	dI mm	ΔI mm	dI mm	ΔI mm	dI mm	ΔI mm				
	16.00	6.00	16.00	6.00	16.00	6.00	16.00	6.00				
NO. 1	0.07	-0.79	1.62	0.88	0.14	1.48	-0.34	-1.08	1.48	-0.81	-1.43	1.24
NO. 2	0.07	-0.68	1.50	0.69	0.21	0.96	-0.30	-0.95	1.30			
NO. 3	0.54	0	1.08									
NO. 4	0.02	-0.67	1.38	0.67	0.25	0.84	-0.40	-0.92	1.04	-0.78	-1.18	0.80
NO. 5			0.64	0.25	0.78	-0.03	-0.54	1.02	-0.48	-0.85	0.74	
NO. 6			0.90	0.19	1.42	-0.42	-1.12	1.42	-0.92	-1.46	1.08	
Temp. °C	36.7	14.1	42.7	26.2		22.0	7.6		10.5	-2.0		

Time of measured standard is am. 8.00 25 July 1968 and temperature is 28 °C.

The dI is values of actual measurement for $L=3.60m$.

The ΔI is displacement between one day in the case of calculated values as $L = 7.20m$

The temperature is position into concrete below 6cm from surface.

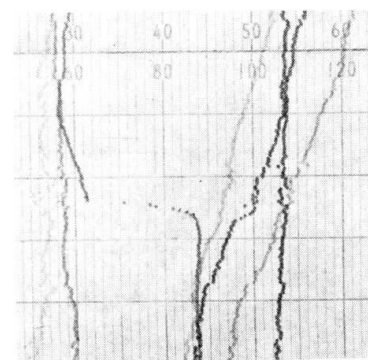

Photo. 4 Crack width of opening up by recording paper

automatic recording is carried out. Since the differential transformer is easily affected by heat, an insulating case of urethane is provided around it (see photo. 3) to eliminate the influence of heat while moreover a dummy is provided for making corrections.

Fig. 6 gives the results of measurements made on the locations from No. 1 through No. 4 employing this apparatus. It can be seen from this figure that there are great changes in strain at the outer end portion. The temperature changes at the center of the concrete roof slab also recorded showing strain to vary accompanying temperature changes at that time.

In this amount of strain, since five years have elapsed from the time of completion of the building, minute cracks have been formed and all factors such as drying shrinkage, creep and thermal behavior are needless to say contained in the figures.

Temperature changes and strain changes for 10-day periods of each season (summer, autumn, winter) in illustrated form are as given in Fig. 7. Representative values by season taken from this figure and sought as behavior instead of strain quantities at 0600 and 1600 hours are shown in table 1.

(C) Measurement of crack width.

Setting the matter of crack formation lay aside, the behavior in widths of cracks already formed were measured. Crack were found to be around 0.5 mm in width. The location of the crack is shown in Fig. 8. Strain measurement apparatus were installed astride these cracks with gage lengths of 10 cm and the behavior recorded. As a reference, the strain in Span No. 3 was also measured. The behavior of the two are given in Fig. 8. From this it is seen there is no effect on span strain although crack width is contracted when the concrete is expanded. During seasons of daytime outdoor of above 30°C the crack try to open up in the night-time (around 2100 to 2200 hours) when heat is being released, but are resisted by bond of reinforcing steel so that an equilibrium condition is maintained — when the equilibrium can no longer be maintained the phenomenon of an instantaneous opening up is seen. Although the amount of this opening up is about 0.12 mm it is believed local stresses are of considerable magnitude in comparison with the length of the opening measured. Photographic evidence of this record is shown in Phto. 4.

Analyses by Thermal Stresses of Frame

Calculations based on thermal stresses were made for the time being assuming the frame to be elasticity. The cross sections of the various members are indicated in Fig. 9. Based on these and assuming a difference of $\pm 30^{\circ}\text{C}$ with the standard temperature, stress and deformation are sought as shown in Fig. 10, where $E = 2.1 \times 10^5 \text{ kg/cm}^2$ and coefficient of thermal expansion of concrete $\alpha = 1.2 \times 10^{-5} \text{ m/m}^{\circ}\text{C}$. As a reference, the stress employed in designing is also given, the calculation being made for seismic coefficient of $K = 0.2$.

From the results it is seen that thermal stresses are large when there is a temperature difference of 30°C .

Next, for crack formation at outer columns, inner columns and outside and inside ends of beams, reinforcing steel strain of 0.1%, and at yield of reinforcing steel, the bending moments and curvature of the various members were sought and are given as shown in Table 2. The relationships of bending moment with curvature

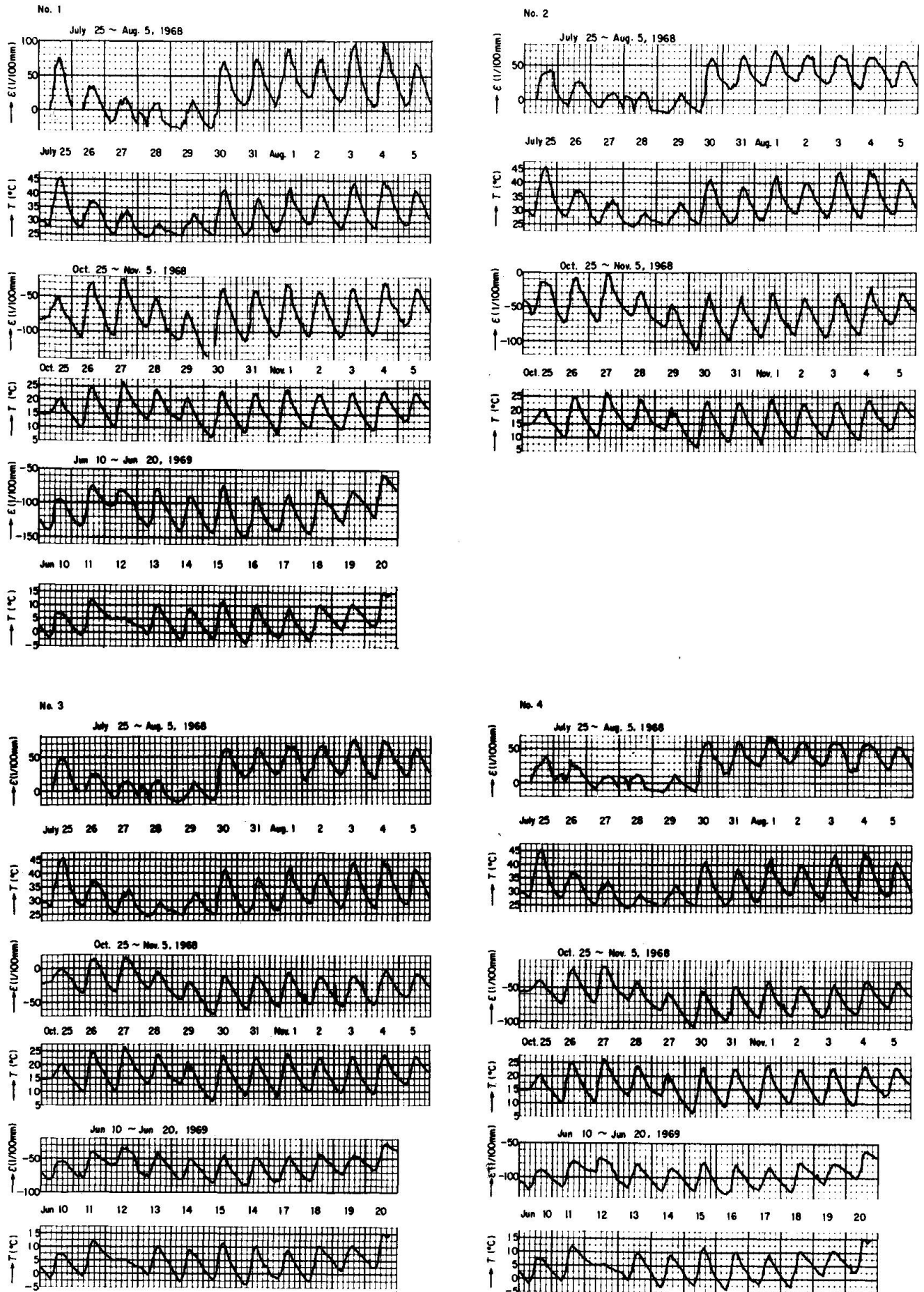

Fig. 7 Strain change of strain and temperature change in slab between seasons.

are indicated in Fig. 11. From these it is seen there is slight lowering of rigidity in columns, but a tendency for considerable lowering in beams.

From the calculation results it is seen that the first cracks are produced at the foots of columns, and the temperature difference sought from these calculated values is 9.3°C . In other words, this frame will enter the plastic range if a temperature difference of more than 9.3°C occurs and the stresses in Fig. 11 will be more or less changed.

The assumptions used in the calculations were:

Yield point of reinforcing steel:	$s\sigma_y = 3,000 \text{ kg/cm}^2$
Yield strain of reinforcing steel:	$s\varepsilon_y = 0.142\%$
Young's modulus of reinforcing steel parallel to ε axis after yield:	$sE = 2.1 \times 10^6 \text{ kg/cm}^2$
Concrete strength:	$c\sigma_b = 200 \text{ kg/cm}^2$
Strain of concrete:	$c\varepsilon_b = 0.2\%$

Closure

This study was made to seek stresses from elastic analyses stressing actual measurements with cross-sectional properties of the various members examined for elastoplasticity. In future studies it is necessary for elastoplasticity of the frame to be investigated for further clarification.

On the other hand, from the above results, when designing is carried out for waterproofing of roof slabs where heat is transmitted directly down to concrete it becomes necessary for stress analyses to be made considering the thermal properties anticipated of the various members of the frame:

As a method of waterproofing, it is observed that the temperature of concrete is maintained at a relatively constant level throughout the year if insulating material is inserted between the waterproofing and concrete and this is shown in Fig. 12. For comparison purposes, a case of rubber sheet waterproofing with no insulating material is also indicated.

In order to understand basic matters, besides drying shrinkage tests of concrete conducted in the laboratory, it is strongly felt that gaining a grasp of the physical properties of concrete members under various circumstances applying temperature factors corresponding to outdoor and indoor and indoor temperatures to concrete specimens is a matter of great importance.

In closing, the authors wish to express their deepest gratitude to Prof. H. Umemura of the University of Tokyo for his guidance in conduction of the tests.

Reference

Kiyoshi Muto: Plastic Design of Reinforced Concrete Structures, Vol. II, Earthquake-Resistance Design Series, Maruzen Co. (in Japanese)

Table - 2

Occasion	Member	Outside Column ($\sigma_0=6.2$)	Inside Column ($\sigma_0=10.4$)	Girder ($\sigma_0=0$)
When crack occurred concrete	Bending moment M : ton-m	4.3	4.3	9.1
	Resistant moment $C = \frac{M}{bd^2}$ kg/cm ²	7.9	7.9	6.2
	Curvature $\frac{1}{R_0}$	0.036×10^{-2}	0.038×10^{-2}	0.031×10^{-2}
When strain of reinforced bar developed 0.1%	Bending moment M : ton-m	11.1	10.4	15.3
	Resistant moment $C = \frac{M}{bd^2}$ kg/cm ²	20.2	19.0	10.4
	Curvature $\frac{1}{R_0}$	0.145×10^{-2}	0.146×10^{-2}	0.134×10^{-2}
When reinforced bar reached yield	Bending moment M ton-m	13.6	12.5	21.7
	Resistant moment $C = \frac{M}{bd^2}$ kg/cm ²	24.7	22.8	14.8
	Curvature $\frac{1}{R_0}$	0.204×10^{-2}	0.205×10^{-2}	0.188×10^{-2}

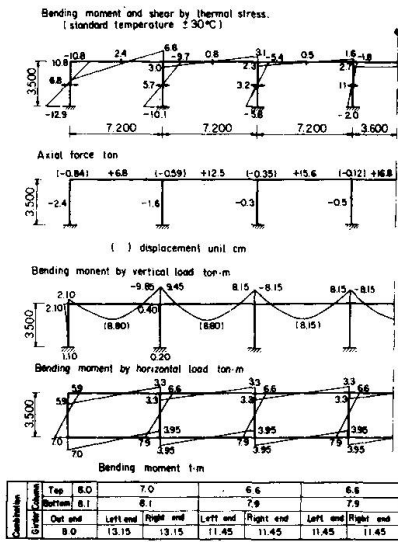

Fig. 10 Stress diagram.

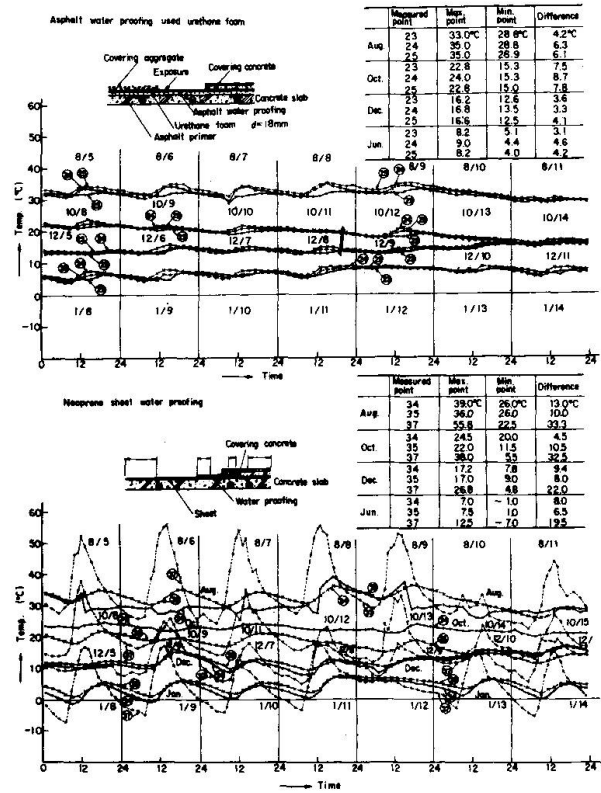

Fig. 12 State of transmission of temperature on water proofing regard to R.C. slab.

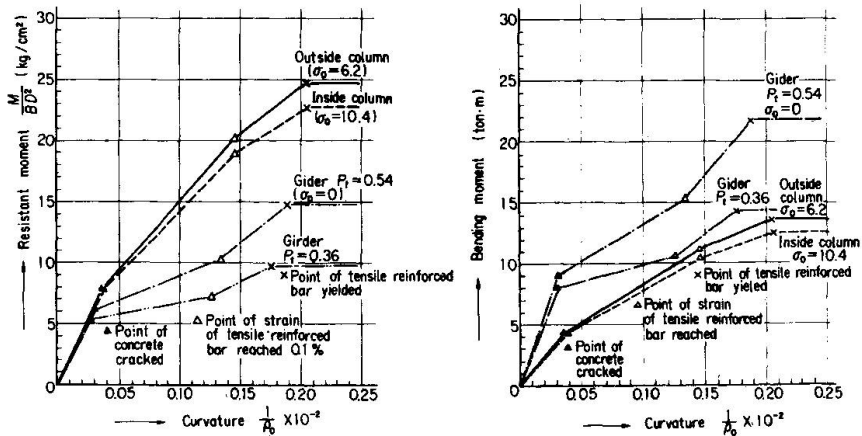

Fig. 11

SUMMARY

The behavior of expansion and contraction of a reinforced concrete building have been measured from May 1967 and is being continued still now. The results of observations showed that behavior of R. C. structure was related to the temperature changes in concrete, and the instantaneous increasing of crack width was observed in night-time especially when outdoor temperature of daytime raised more than 30°C. Some other analysis were examined on the observed data.

RESUME

On a effectué des mesures d'extension et de contraction sur un bâtiment de béton armé à partir de mai 1967. Les résultats des observations montrent que le comportement de la structure de béton armé est lié à la variation de la température dans le béton. En particulier, quand la température de l'air extérieur dépassait 30°C de jour, on a observé de nuit que la largeur de la fissure augmentait. On a tenté l'analyse des résultats des mesures.

ZUSAMMENFASSUNG

Seit Mai 1967 wird das Verhalten der Ausdehnung und des Zusammenziehens eines Stahlbetongebäudes gemessen. Die Beobachtungen zeigten, dass das Verhalten des Stahlbetongebäudes in Beziehung zur Temperaturänderung im Beton stand. Insbesondere wurde eine Zunahme der Rissweiten in der Nacht beobachtet, wenn die Aussen-temperatur tagsüber über 30°C gestiegen war. Weitere Untersuchungen aufgrund der beobachteten Werte wurden vorgenommen.

Leere Seite
Blank page
Page vide