

Zeitschrift: IABSE reports = Rapports AIPC = IVBH Berichte
Band: 51 (1986)

Artikel: Risk analysis and protective island design for ship collisions
Autor: Havnø, Karsten / Knott, Michael
DOI: <https://doi.org/10.5169/seals-39576>

Nutzungsbedingungen

Die ETH-Bibliothek ist die Anbieterin der digitalisierten Zeitschriften. Sie besitzt keine Urheberrechte an den Zeitschriften und ist nicht verantwortlich für deren Inhalte. Die Rechte liegen in der Regel bei den Herausgebern beziehungsweise den externen Rechteinhabern. [Siehe Rechtliche Hinweise.](#)

Conditions d'utilisation

L'ETH Library est le fournisseur des revues numérisées. Elle ne détient aucun droit d'auteur sur les revues et n'est pas responsable de leur contenu. En règle générale, les droits sont détenus par les éditeurs ou les détenteurs de droits externes. [Voir Informations légales.](#)

Terms of use

The ETH Library is the provider of the digitised journals. It does not own any copyrights to the journals and is not responsible for their content. The rights usually lie with the publishers or the external rights holders. [See Legal notice.](#)

Download PDF: 01.04.2025

ETH-Bibliothek Zürich, E-Periodica, <https://www.e-periodica.ch>

Risk Analysis and Protective Island Design for Ship Collisions

Analyse de risque et projet d'îlots protecteurs contre les collisions de bateaux

Risiko-Analyse und Entwurf von Schutzinseln gegen Schiffskollisionen

Karsten HAVNØ

Senior Hydraulic Engineer
Danish Hydraulic Institute
Hørsholm, Denmark

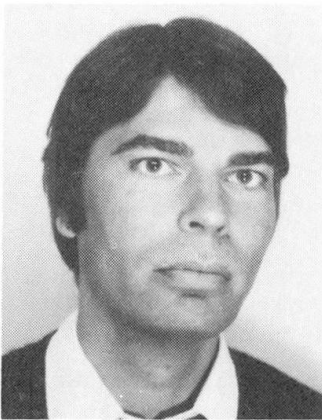

Michael KNOTT

Senior Structural Engineer
Greiner Engineering Sciences
Tampa, FL, USA



SUMMARY

The paper describes a combined approach for assessment of collision risks and optimization of protective structure designs. A mathematical model has been developed which simulates with all 6 degrees of freedom the collision scenarios and resulting impact forces. In its most general form the model can describe the deformations of both vessel and protective structure simultaneously. The risk analysis and the optimization of island designs have been applied to the new Sunshine Skyway Bridge, across Tampa Bay, Florida, which is used as an example in the contribution.

RÉSUMÉ

La contribution décrit une approche combinée pour l'évaluation des risques de collisions et l'optimisation du projet de constructions protectrices. Un modèle mathématique a été développé; il simule, avec six degrés de liberté, les scénarios de collisions et les forces d'impact qui en résultent. Dans sa forme la plus générale, le modèle peut décrire simultanément les déformations du bateau et des constructions protectrices. Les analyses de risques et l'optimisation du projet d'îlots protecteurs ont été appliqués au pont Sunshine Skyway, Tampa Bay, Floride, et est présenté comme exemple dans cette contribution.

ZUSAMMENFASSUNG

Der Artikel beschreibt einen kombinierten Ansatz für die Beurteilung von Kollisionsrisiken und die Optimierung des Entwurfes von Schutzkonstruktionen. Ein mathematisches Modell wurde entwickelt, welches das Kollisionsgeschehen mit allen sechs Freiheitsgraden und die zugehörigen Stosskräfte simulieren kann. In der allgemeinsten Form lassen sich die Deformationen sowohl des Schiffs als auch der Schutz-Konstruktion beschreiben. Das Modell wurde auf das Projekt der neuen Sunshine Skyway Brücke über die Tampa Bay in Florida angewendet, welche auch im vorliegenden Beitrag als Beispiel dient.



1. INTRODUCTION

On May 9, 1980 during an intense early-morning thunderstorm, the empty 40,000 dwt bulk carrier M/V Summit Venture struck one of the anchor piers of the two parallel bridge structures. A 396m section of the southbound main span collapsed, and 35 lives were lost in vehicles which fell into the bay. The Florida Department of Transportation is currently replacing the existing bridge with a new 6.705 km-long replacement structure. The new structure (Fig. 1.1) has a 365.8m single-plane, cable-stayed, segmental concrete main span. In the background of Fig. 1.1 can be seen the existing parallel bridges, one of which was partially destroyed by the ship collision.

The Skyway Bridge failure, and other similar bridge failures around the world, has resulted in an increased awareness in the international engineering community of the need to include ship impact as a major design condition in bridges and offshore structures located in busy marine waterways. The IABSE Colloquium on "Ship Collision with Bridges and Offshore Structures" /1/ in Copenhagen, 1983 established the state-of-the-art of the current understanding of ship impact within the profession.

2. PIER PROTECTION SYSTEM

2.1 Risk Analysis

The final selection of the pier protection system to be constructed for new bridges was based on the results of detailed studies of numerous alternative protection systems using risk analysis and cost-effectiveness techniques /2/.

The risk analysis methodology results in an assessment of the annual frequency of ship collision with any part of the bridge structure (either pier or spans) and the annual frequency of bridge collapse. The methodology involves the complex organization of a large body of data into a series of calculations involving various statistical and probability procedures. Factors included in the analysis are:

- Frequency and vessel size distribution of the ship/barge fleet passing under the bridge
- Probability of vessel aberrancy
- Geometric probability of collision based on vessel sailing paths, vessel dimensions, and bridge geometry
- Impact strength of the bridge pier and span components
- Impact force of the ship/barge based on vessel displacement and speed
- Local weather conditions, currents, tides, and pilotage standards
- Costs associated with bridge repair and replacement, port interruption, motorist interruption, and loss of human life costs.

| Pier No. (N&S) | Unprotected (Years) | Protected (Years) |
|-------------------|------------------------|----------------------|
| 1 | 80 | - |
| 2 | 138 | 3442 |
| 3 | 262 | 1458 |
| 4 | 552 | 1106 |
| 5 | 1492 | 2984 |
| 6 | 2804 | 8000 |
| Total | 38 | 427 |

Table 2.1 Return Periods of Bridge Collapse.

The recommended protection system consists of 1) physical protection of the first six piers on each side of the channel using a combination of dolphins and islands to protect the main pier and dolphin protection around the remaining piers, (Fig. 2.1), 2) a motorist warning system on the bridge structure, and 3) an electronic navigation device to be carried aboard the vessels by the local harbor pilots. The remainder of this paper will discuss the method of analysis used to evaluate the main pier artificial island to protect the main pier from potential ship collisions.



Fig. 1.1 Construction of the new Sunshine Skyway Bridge.

Once the results of the analysis of the unprotected structure have been evaluated, a protection system can be developed. Table 2.1 summarizes the results of the Skyway analysis for the main span portion of the bridge with the physical protection system described below.

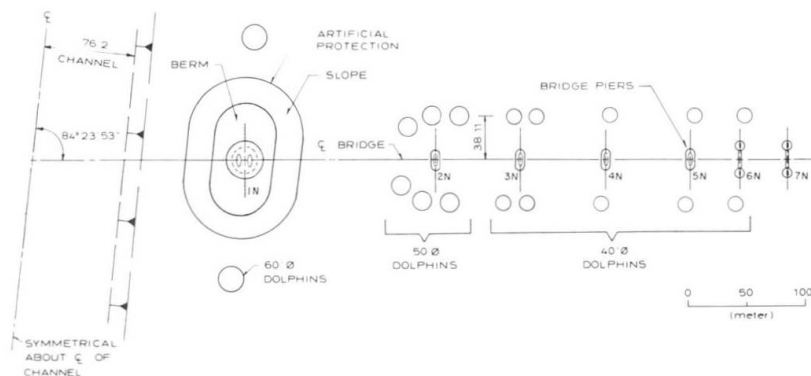

Fig. 2.1 Protection System for the new Skyway Bridge.

2.2 Protection with Artificial Islands

By ship collision, impact energy is mainly absorbed through the deformation of the island material and deformation of the ships bow. In front of the ships bow, a force is transmitted through the island material and part of this might be transmitted to the bridge pier.

Both mathematical and physical models can be constructed to represent the situation with deformable ship and deformable island. However, it is often adequate for design purposes to assume a rigid vessel, and hence a situation, where only the island is deforming. For the Skyway Pier Protection study, the rigid vessel impact was studied both in a mathematical and a physical model, and the applicability of the rigid approach was verified with a mathematical model which includes the description of the ships deformation, /3/.

The second part of this paper mainly concerns the mathematical modelling, but also gives comparisons with the physical model results.

3. MATHEMATICAL MODEL FORMULATION

3.1 General Formulation of Equations of Motion

The equations of the vessel's motion are expressed by using two Cartesian frames of reference:



1. A fixed Cartesian frame, Frame I, with horizontal x- and y-axes and a vertical z-axis.
2. A Cartesian frame, Frame A, which is fixed relative to the vessel, with origin in the vessel's centre of gravity and x_A - and y_A -axis coinciding with the vessel's longitudinal and transversal axis, respectively. The angular displacements of the rotational motion around this frame axis are denoted RZ, RY and RX.

The relationship between coordinates of the two frames becomes

$$\begin{pmatrix} x \\ y \\ z \end{pmatrix} = \begin{pmatrix} X_G \\ Y_G \\ Z_G \end{pmatrix} + \begin{pmatrix} C_{11} & C_{12} & C_{13} \\ C_{21} & C_{22} & C_{23} \\ C_{31} & C_{32} & C_{33} \end{pmatrix} \begin{pmatrix} X_A \\ Y_A \\ Z_A \end{pmatrix}, \text{ where}$$

$$\begin{aligned} C_{11} &= \cos RY \cos RZ & C_{31} &= -\sin RY \\ C_{12} &= \sin RX \sin RY \cos RZ - \cos RX \sin RZ & C_{32} &= \sin RX \cos RY \\ C_{13} &= \cos RX \sin RY \cos RZ + \sin RX \sin RZ & C_{33} &= \cos RX \cos RY \\ C_{21} &= \cos RY \sin RZ \\ C_{22} &= \sin RX \sin RY \sin RZ + \cos RX \cos RZ \\ C_{23} &= \cos RX \sin RY \sin RZ - \sin RX \cos RZ \end{aligned}$$

and X_G , Y_G and Z_G denote the translatory displacements of the vessel's centre of gravity.

3.2 Formulation of Earth Pressure with Rigid Vessel Assumption

A mathematical formulation of the earth pressure forces on a vessels bow which penetrates an island was formulated by the Danish Geotechnical Institute in connection with the Danish Great Belt Bridge study.

The formulation, which is based on analytical considerations and physical model tests, yields a force perpendicular to the vessel bow; Account is made for higher earth pressures which occur when the ship bow is at the slope of the island, and the formation of a sand bank which forms at the front of the bow as the vessel pushes into the island.

In the numerical integration, the ship's bow is mathematically divided into a number of slices. For each slice, the contact force is estimated for the centerpoint in that slice, and also the resulting friction force is calculated, see Fig. 3.1.

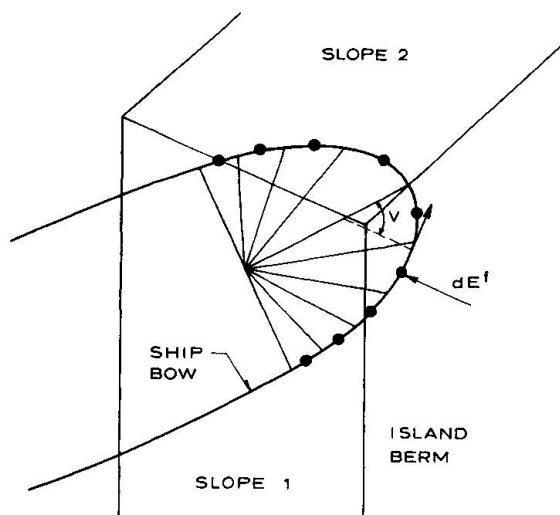

Fig. 3.1 Ship bow discretization

The vertical position of the point of impact is estimated from the assumption, that the earth pressure varies linearly with depth in the wet and the dry part of the island, respectively.

3.3 Formulation for Deformable Vessel Assumption

At a certain depth below the islands surface, the earth pressure will exceed the strength of the vessel, which deforms. This phenomena has been incorporated in a more general mathematical formulation with the above presented earth pressure description for the upper (undeformed) part of the ships bow, and a force formulation according to plastic bow deformation for the lower part. The division between the two descriptions is assumed to follow the plane within the island, where the earth pressure equals the ship strength.

The shape of this plane can be estimated from the soil characteristics, and will generally appear as in Fig. 3.2.

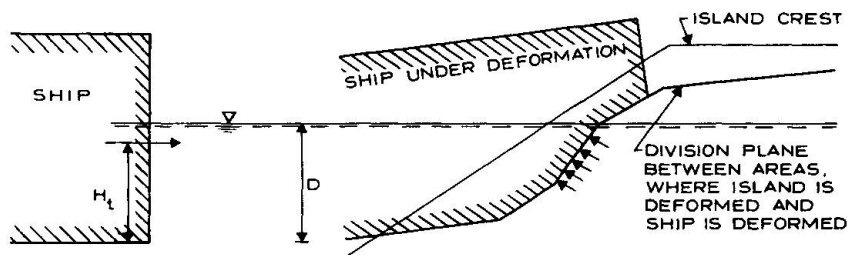

Fig. 3.2 Division Plane with equal Earth Pressure and Ship Strength

The generalized equations become rather complex and it is necessary to switch between equations concurrently when the deformation develops, but the solution technique is essentially the same as earlier described.

4. FORMULATION OF FORCE TRANSMISSION

The force transmission in front of the ship's bow through the island material to the bridge pier has been formulated assuming a conical shaped force distribution, see Fig. 4.1.

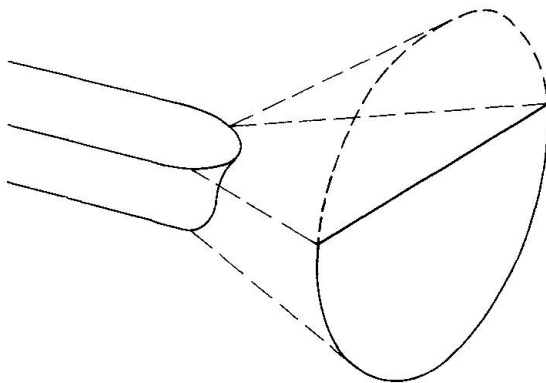

Fig. 4.1 Conical Force Distribution

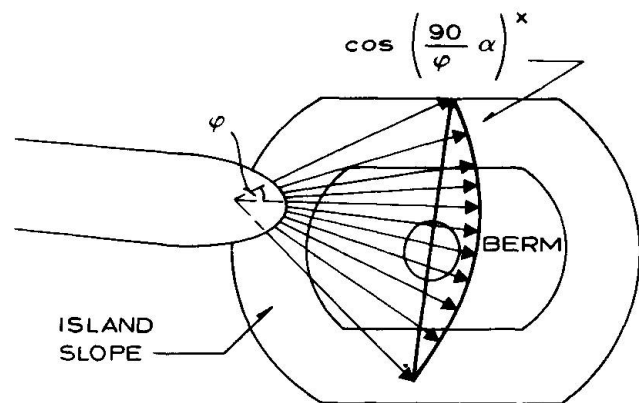

Fig 4.2 Horizontal Force Distribution

The active part of the cone will be the part which is situated inside the island, and the boundary values for the forces are known to be zero at the island crest and at the cone intersection.

The horizontal force distribution is approximated with a cosine function, the shape of which can be calibrated, see Fig. 4.2.

The vertical force distribution is assumed to grow linearly to its maximum at the bottom of the vessel, and to decrease thereafter with a function, which is subject to calibration, see Fig. 4.3.

The centerline of the cone is assumed to coincide with the resulting collision force, acting on the ship.

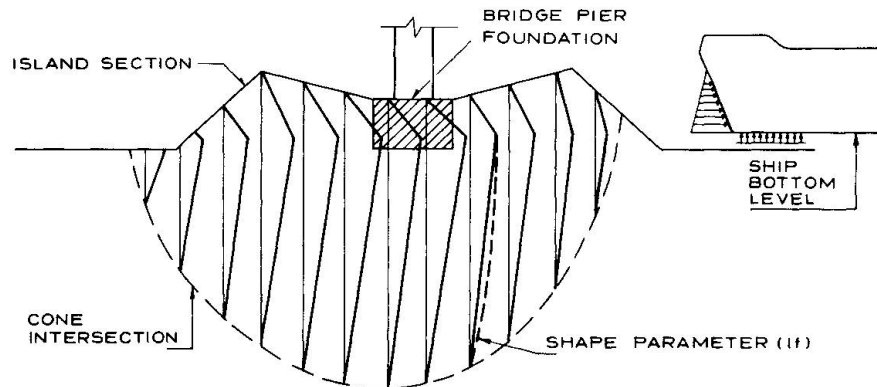

Fig. 4.3 Vertical Force Distribution

5. MODEL VERIFICATION/ISLAND DESIGN

5.1 Islands Stopping Ability

The mathematical model description of the protection islands with respect to stopping or deflecting approaching ships has been verified against two series of physical model tests:

- a) The model tests for the Danish Great Belt bridge, which were carried out by DHI in early 1978.
- b) The model tests for the Sunshine Skyway Pier Protection, which were carried out by Hydro Research Science Inc., in early 1984.

For both test-series, a good agreement for vessel intrusion in the islands was found between the mathematical and physical model, see Fig. 5.1.

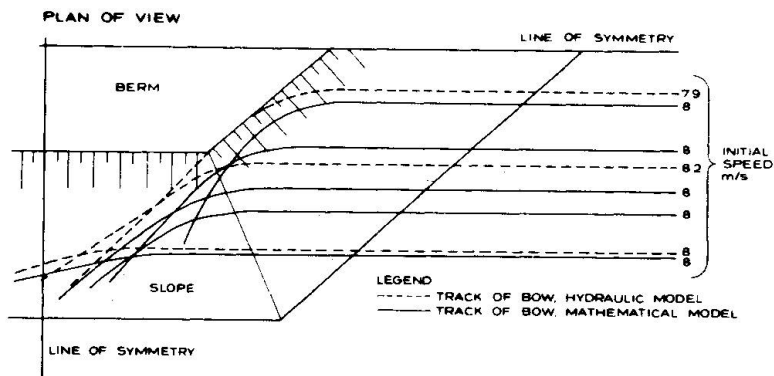

Fig. 5.1 Model Verification, Stopping and Deflection (Great Belt Bridge)

5.2 Force Transmission

Only little knowledge is available at present to support a complete formulation of the force transmission through the island material. The formulation used is based on static geotechnical considerations, and does not account for the dynamic effects.

However, with respect to the forces transmitted to the bridge pier, a fair agreement is found with the physical model tests for relatively high impact forces, which will be the design conditions.

Fig. 5.2 presents comparisons between the mathematical model formulation, the Great Belt Bridge tests and the Sunshine Skyway Pier protection tests with relatively high transmitted forces. The mathematical formulation has been presented as a straight line, defining the abscissa for each test on the horizontal axis. The corresponding measured ratios have been plotted along the ordinate.



5.3 Rigid Model Description

The rigid model assumption does not account for ships with large drafts, due to deformation of the ships bow. However, as the effective stopping length for these ships is relatively small, this deformation has only limited effect on the islands ability to stop the ship. Still, there can be a noteworthy decrease in the collision force, when the ships deformation is taken into account, and with respect to the force transmitted to the pier, a safety margin is thus built in the rigid assumption. Decreases in the transmitted impact force greater than 25% were estimated using a mathematical model with a deformable bow during this study.

5.4 Island Design

The final island design for the Sunshine Skyway Pier protection was derived in the following manner; first the mathematical model was used to define an approximate island layout, which was then tested in the physical model tests. Then the results from the physical model tests were used to calibrate the mathematical model before the final design simulations.

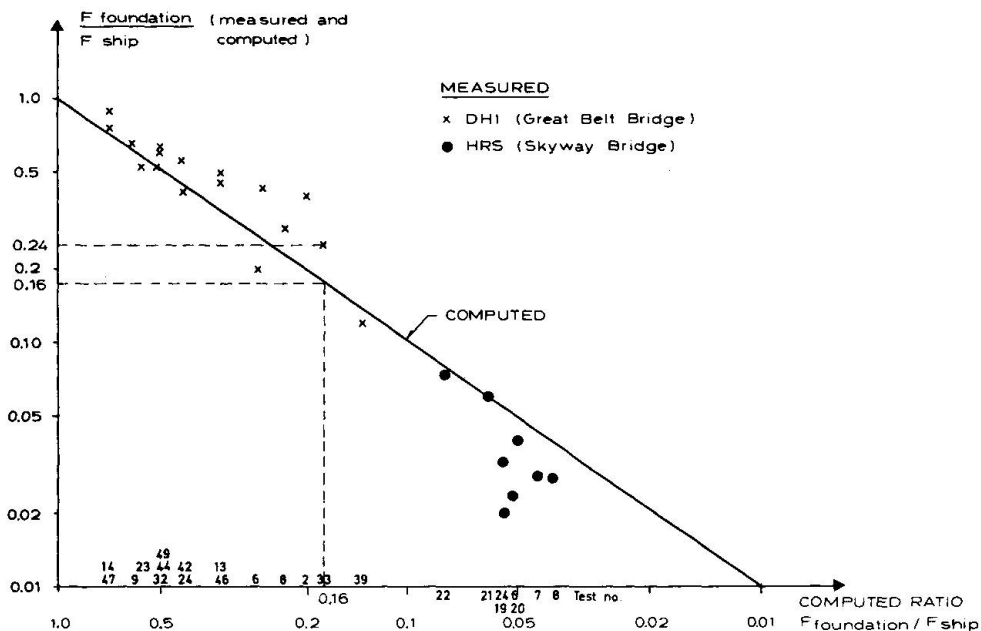

Fig. 5.2 Ratio between Pillar Force and Ship Force in Mathematical and Physical Models

The selected island section for the main pier protection island is shown on Fig. 5.3.

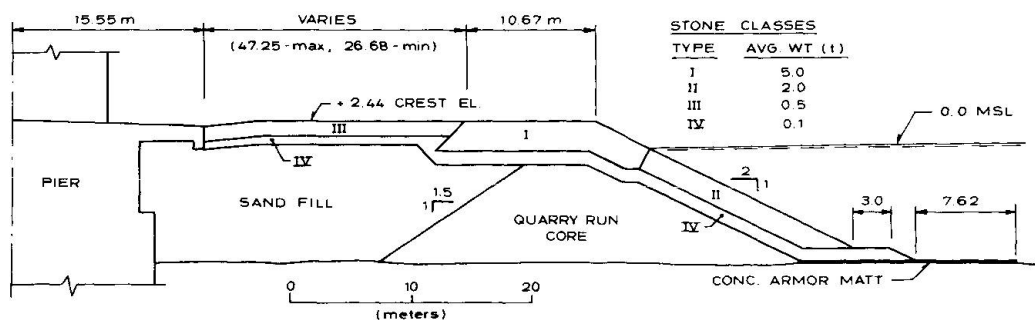

Fig. 5.3 Final Main Pier Island Design



For the design conditions, which involved various ship types, loading conditions, ship sizes up to 85,000 DWT, travelling speeds of 10 knots and extreme high water level conditions up to 0.73 m above mean sea level, the island was found to give sufficient protection to the piers.

The most dangerous situation was found to be the one, where an empty, trimmed vessel strikes the island under high water conditions. In this situation, the vessel tends to slide over the island, but is stopped about 6.1 m in front of the pier, see Fig. 5.4.

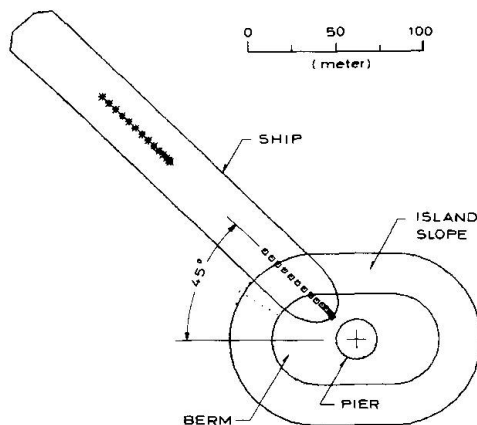

Fig. 5.5 Empty trimmed 85,000 DWT vessel hitting the Island with 10 Knots Speed in Extreme High Water

Due to the lifting of the ships bow, only little force is transmitted to the pier in this case.

5. CONCLUSION

For bridges and offshore structures located in waterways with merchant vessel activity, the potential for catastrophic ship collision must be evaluated in order to provide for a safe structure. The example of the Skyway bridge shows the incorporation of risk analysis and cost-effectiveness to establish the necessary pier protection system. An innovative island protection system which was evaluated with both physical and mathematical models was developed for the project.

6. REFERENCES

1. IABSE Colloquium "Ship Collision with Bridges and Offshore Structures", Copenhagen 1983, 3 vols.
2. GREINER ENGINEERING SCIENCES, Inc. "Ship Collision Risk Analysis for Sunshine Skyway Bridge Replacement", Prepared for Florida Department of Transportation, December 1985.
3. DANISH HYDRAULIC INSTITUTE, "Sunshine Skyway Pier Protection - Mathematical Model Ship Collision Results", Final Report, April 1984.