

Zeitschrift: IABSE reports = Rapports AIPC = IVBH Berichte

Band: 55 (1987)

Artikel: Innovative methods of segmental concrete tunnel lining

Autor: Shorland, Rohan D.

DOI: <https://doi.org/10.5169/seals-42780>

Nutzungsbedingungen

Die ETH-Bibliothek ist die Anbieterin der digitalisierten Zeitschriften. Sie besitzt keine Urheberrechte an den Zeitschriften und ist nicht verantwortlich für deren Inhalte. Die Rechte liegen in der Regel bei den Herausgebern beziehungsweise den externen Rechteinhabern. [Siehe Rechtliche Hinweise.](#)

Conditions d'utilisation

L'ETH Library est le fournisseur des revues numérisées. Elle ne détient aucun droit d'auteur sur les revues et n'est pas responsable de leur contenu. En règle générale, les droits sont détenus par les éditeurs ou les détenteurs de droits externes. [Voir Informations légales.](#)

Terms of use

The ETH Library is the provider of the digitised journals. It does not own any copyrights to the journals and is not responsible for their content. The rights usually lie with the publishers or the external rights holders. [See Legal notice.](#)

Download PDF: 02.04.2025

ETH-Bibliothek Zürich, E-Periodica, <https://www.e-periodica.ch>

Innovative Methods of Segmental Concrete Tunnel Lining

Méthode innovante de revêtement de tunnel par voussoirs préfabriqués

Neuere Methode von Tunnelbekleidung mit Fertigbauteile

Rohan D. SHORLAND
General Manager
Camponon Bernard Singapore
Piling Civil Contractors

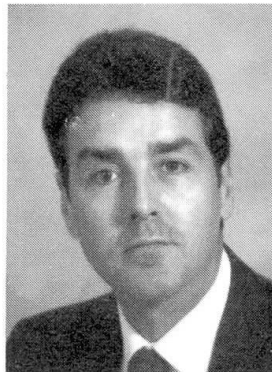

Bachelor of Engineering
Chartered Engineer
Fellow of the Institution of Civil Engineers
Associate of the Chartered Institute
of Arbitrators

SUMMARY

The conditions and constraints imposed by the client's specification, the geological conditions and the search by Camponon Bernard for the most economical general solution in the Turnkey design and construct Metro in Singapore led to an innovative conception and design of the concrete tunnel structures combined with an integrated tunnel guidance system.

RÉSUMÉ

Les conditions et contraintes imposées par l'avant-projet du client, les conditions géologiques ainsi que la recherche par les ingénieurs de Camponon Bernard de la solution la plus économique pour la réalisation clé en main du Métro de Singapour ont débouché sur une conception innovante des structures en béton du tunnel combinée à un système intégré de guidage du tunnelier.

ZUSAMMENFASSUNG

Die Ingenieure von Camponon Bernard die, die U-Bahn in Singapour entwarfen, mussten auf die folgenden Bedingungen Rücksicht nehmen :

- Achtung der Einrichtungen des Vorentwurfes
- Geologischen Verhältnisse
- Forschung nach der sparsamsten Lösung

Sie sind zu einer neuen Erfindung der Tunnelbetonstruktur und zu einem integrierten System der Lenkung der Tunnelaushöhlmaschine gelangen.



BACKGROUND

This paper describes how Campenon Bernard dealt with the conception and design of the tunnels on the Singapore Metro project.

The tunnels to be driven on either side of Dhoby Ghaut station (Contract 106) were four sections of 600 to 700 metres in length with a minimum depth of overburden of between 10 and 20 metres. Most of the tunnelling was through weathered rocks which were quite stable during the excavation and had a low permeability.

The variety of soils expected to be encountered and the shallow overburden lead to the selection of a tunnelling method using a shield so that the ground could be supported immediately after excavation and the final lining could be placed within a few metres of the face in order to reduce surface settlements as much as possible.

The low permeability of the ground and the medium range strengths favoured the use of an open face machine working in free air. Most of the excavation was performed by an hydraulic back-hoe installed within the shield machine.

CONSTRAINTS ON TURNKEY CONCEPTION AND DETAILED DESIGN

A number of constraints determined the final design decisions some of which could be dealt with in isolation and some which had to be considered in combination with others.

1. Tunnel geometry

The tunnel alignment included a series of vertical and horizontal and composite curves. Only approximately 20 % of the route was on straight section. The tightest radius curves on the route were of 2500 m radius.

2. Kinetic envelope

The kinetic envelope for the passage of the trains was defined by the client to suit his overall requirements for the project. This envelope or clear section had to be respected under all circumstances by the designer (Fig. 1).

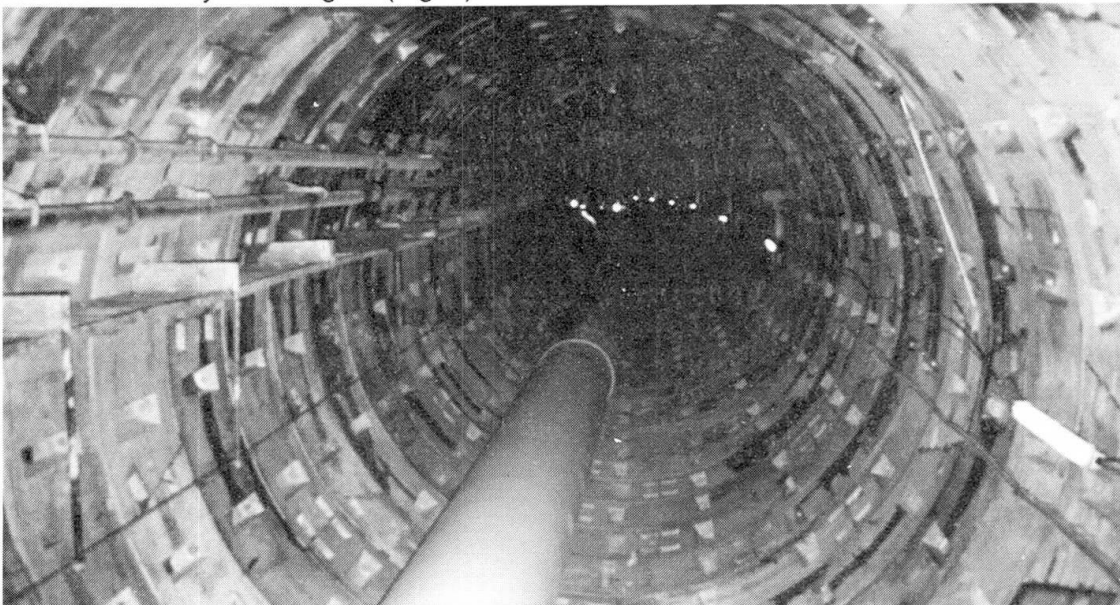

Fig. 1 General view of lined tunnel

3. Structural stability

The influence of ground load conditions on the structure for short and long term loading had to be estimated from the ground characteristic parameters obtained during the soils investigations. From the estimated load cases a preliminary lining thickness could be calculated and used as the basis for following design decisions.

4. Watertightness

The client's specification required that water seepage into the finished tunnel does not exceed 10 ml/m²/hr. for a 10 m length of tunnel. This represents an extremely tight specification and consequently the designer had to design for a perfectly watertight structure.

5. Speed and efficiency of the tunneling operation

The designers had to provide a total system which was compatible with the contracted speeds of tunnelling required. In this case an average speed of 50 m/week per heading had to be achieved with maximum speeds of over 60 m/week.

THE SOLUTION ADOPTED

Considering the various design constraints individually and together the designers opted to develop the concept of tapered reinforced concrete precast segmental lining (Fig. 2).

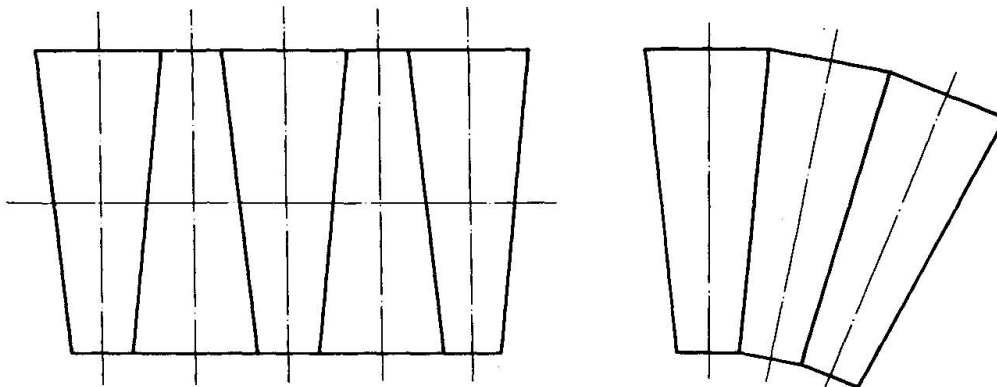

TAPERED RINGS ALIGNED IN STRAIGHT SECTION AND CURVED SECTION

Fig. 2 General principles of tapered rings

Tapered rings can be used in two ways :

- Using tapered rings for curves and parallel rings on straight sections. This allows the key to be in the same position in each ring and the longitudinal joints to be in line. However, this method involves the use of several types of ring which would complicate storage and handling operations and often requires the use of packing between segments to adjust for machine steering errors.
- The use of identical tapered rings throughout, each ring being rotated in order to systematically re-position the axis of the ring parallel to the shield axis.

The second solution was chosen for the following main reasons :

- The large quantity of curves along the route meant that approximately 80 % of the tunnel was in curve and much of that in composite curves.
- The unique geometry eliminates confusion and risk of error in the handling logistics of the rings.
- The design calls for concrete to concrete contact between all rings (no use of packers) and in this way a unique waterproof sealing system could be adopted.



ADDITIONAL CONSIDERATIONS TO THE BASIC CONSTRAINTS

Once the decision had been taken to use a unique tapered ring the philosophy of the construction/design interface had to be studied in greater depth. Such questions as –

- How to assure compatibility with the tunnel machine guidance system ?
- What ring width to use ?
- What taper to use ?
- What key shape to use ?
- What bolting system to use ?
- What structural thickness to use ?
- What construction tolerances to impose ?
- How to ensure watertightness ?
- How to determine the rotated position during construction ?

had to be answered.

1. The basic philosophy which was developed rested upon the principle that the tunnelling machine should be guided and driven as accurately as possible (within tolerances to be defined) and that the tunnel lining should follow the tail end of the machine, the capacity for alignment adjustment provided by the taper being used only to ensure that erection of the lining was possible within the limited space inside the tailskin of the shield. In order to have the most accurate tunnel driving the philosophy called for a guidance system providing a converging target for the operators rather than an instantaneous display of status of actual position.

The shield is steered in order to maintain it as close as possible to the theoretical axis of the tunnel. This is done by using selectively the 18 No. thrust rams which propel the machine forward and by selectively over or under excavating ahead of the machine to give it a direction bias.

2. A width of 1 m was chosen as it is an industry standard which facilitates surveying.

3. The ring taper was designed to allow a maximum radius of curvature of the tunnel of three times the curvature necessary to follow the theoretical alignment. The additional amount was estimated as being the requirement necessary for overcoming local shield steering movements and errors. A taper of 40 mm was provided on the rings of 5320 mm inside diameter and the maximum lining

curve was obtainable by erecting a series of rings with the key in the same position (Fig. 3).

The axis of the rings is the same as the axis of the shield and the maximum variation between two rings is 3.84 mm.

The designers opted for a ZED type 261 guidance system.

This system contains :

- a laser fixed at the crown of the tunnel
- a three dimensional sensing target fixed onto the machine

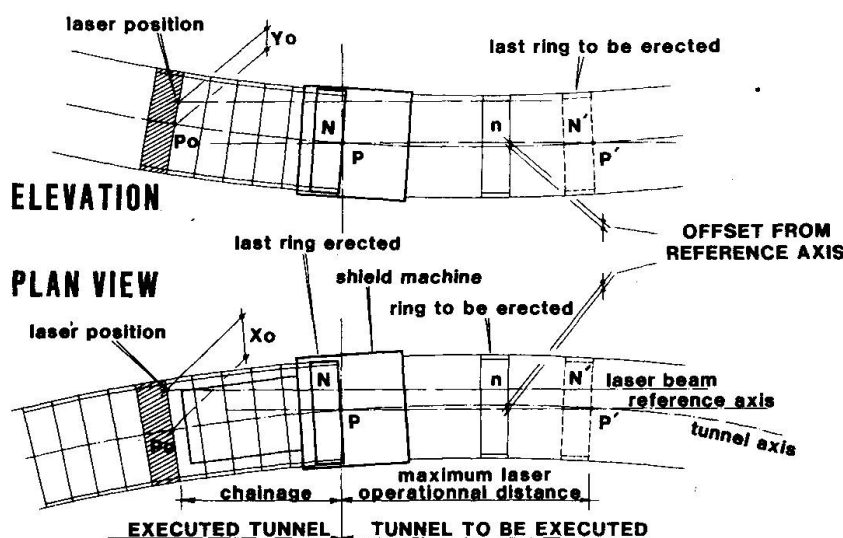

Fig. 3 Section and plan views of the alignment geometry during tunnelling

- two inclinometers
- a memory with the positions of the rings and the laser beam
- a calculator

The system indicates :

- the position of the shield relative to the theoretical
- the shield inclination
- the shield rotation
- the predicted position of the shield 5 m ahead (the predictions are accurate to within a few millimeters)

The display is digital and the laser is of the optical fibre type.

After positioning of the laser the surveyor calculates the theoretical position of the shield relative to the beam every metre and feeds the data to the ZED memory.

The internal diameter of the structure had to be determined on the basis of the kinematic envelope to which additions had to be added to allow for

- segment fabrication tolerances
- erection tolerances
- tunnel driving accuracy
- deflection of rings under load

whilst always searching for the smallest diameter and thinnest wall section.

In this case the kinematic envelope corresponded to an internal diameter of 5200 mm and the designers arrived at the decision of an internal diameter of 5320 mm with a ring thickness of 245 mm.

5. The key shape was determined by the

- available space inside the shield machine
- the characteristics of the segment erecting device envisaged
- structural considerations

A key which is placed against the extremity of the shield chamber and introduced, thin edge first, in the line of the axis of the tunnel under pressure of the shield thrust rams was designed (Fig. 4).

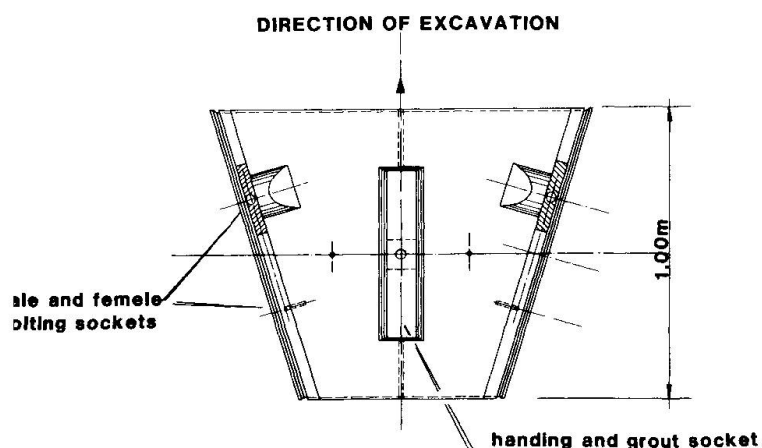

Fig. 4 Key design

inside diameter of the shield machine. The inside diameter of the machine was 70 mm greater than the outside diameter of the concrete segments (an annulus of 35 mm).

6. The strength of the bolting system for the segmental elements of the rings was designed on structural considerations. The segments were bolted together both radially and axially but the axial layout of the bolts was determined by the fact that the rings had to be free to be erected in different orientations. It was decided that 18 No. circular positions should be provided (every 20 degrees) and the bolting configuration was designed accordingly.

7. The structural thickness of the rings was calculated from structural considerations. The thinnest section was sought in order to minimise excavation, concrete and the



8. In order to meet the overall geometric constraints imposed by the designers strict tolerances had to be imposed on the precast manufacture of the segments. These tolerances were respected by a strict quality assurance programme which included regular checking of the segment

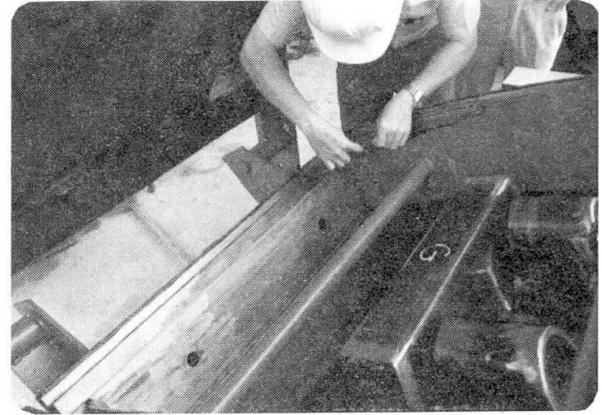
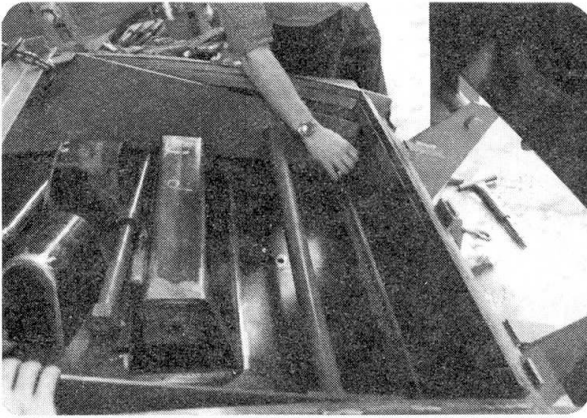

Fig. 5 Checking of mould dimensions

moulds with standard templates (Fig. 5).

9. The watertightness was assured by a continuous neoprene seal fitted around the whole circumference of each segmental element.

The seal is designed to compress to the extent that concrete to concrete structural contact is assured between all elements. The prefabricated seals were glued in place on the site before the transport of the segments into the tunnel.

A caulking groove was provided on the interior of each segment to allow plugging of leaks which may have persisted due to malfunction of the sealing strips.

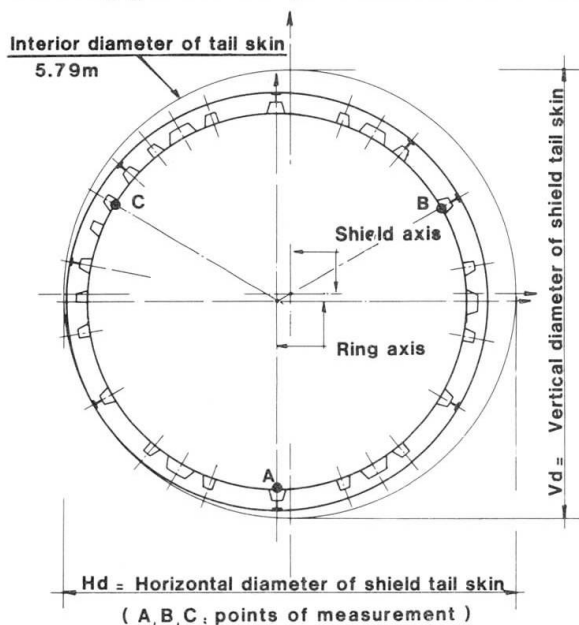

Fig. 6 Eccentricity of ring within the shield machine

10. Because the ring rotations have to be such that the axis of the segments follows the direction of the shield machine the reference to determine the correct orientation is the tail skin of the shield machine.

The position of the last ring erected is measured with respect to the inner edge of the shield tail skin (Fig. 6). Three measurements are made at three standard points (at 120 degrees separation) and the information fed into a pocket calculator with a memorised basic program which provides the operators with the number (1 to 18) of the position of the key for the next ring to be erected.

CONCLUSIONS

The tunnels for the Singapore Metro were constructed within the tolerances specified by Campenon Bernard's designers. The system devised by the Campenon Bernard engineers was compatible with high speed tunnelling of the accuracy required for railway line construction. The tunnelling speeds attained during construction exceeded 80 m/week and the critical path in the tunnelling cycle did not include time lost for survey or determination of ring orientation. The accuracy of the completed project was as required by the design brief and the kinematic envelope was respected.