

Zeitschrift: IABSE reports = Rapports AIPC = IVBH Berichte
Band: 57/1/57/2 (1989)

Artikel: Fatigue strength of corroded steel plates from old railway bridge
Autor: Abe, Hidehiko
DOI: <https://doi.org/10.5169/seals-44213>

Nutzungsbedingungen

Die ETH-Bibliothek ist die Anbieterin der digitalisierten Zeitschriften. Sie besitzt keine Urheberrechte an den Zeitschriften und ist nicht verantwortlich für deren Inhalte. Die Rechte liegen in der Regel bei den Herausgebern beziehungsweise den externen Rechteinhabern. [Siehe Rechtliche Hinweise.](#)

Conditions d'utilisation

L'ETH Library est le fournisseur des revues numérisées. Elle ne détient aucun droit d'auteur sur les revues et n'est pas responsable de leur contenu. En règle générale, les droits sont détenus par les éditeurs ou les détenteurs de droits externes. [Voir Informations légales.](#)

Terms of use

The ETH Library is the provider of the digitised journals. It does not own any copyrights to the journals and is not responsible for their content. The rights usually lie with the publishers or the external rights holders. [See Legal notice.](#)

Download PDF: 02.04.2025

ETH-Bibliothek Zürich, E-Periodica, <https://www.e-periodica.ch>

Fatigue Strength of Corroded Steel Plates from Old Railway Bridge

Résistance à la fatigue de tôles en acier corrodées d'un vieux pont de chemin de fer

Ermüdungsfestigkeit korrodierter Stahlbleche einer alten Eisenbahnbrücke

Hidehiko ABE
Prof. of Civil Eng.
Univ. of Utsunomiya
Utsunomiya, Japan

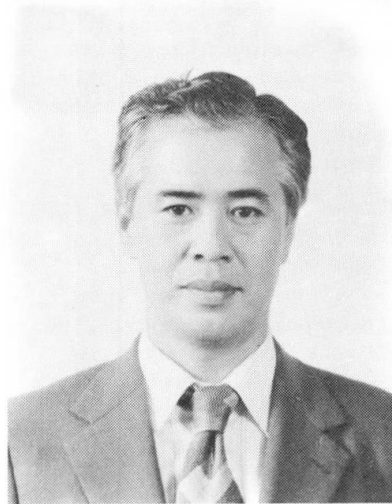

Hidehiko Abe, born 1931, graduated, and received his doctoral degree from the University of Tokyo, Japan. For 30 years he worked for the Japanese National Railways, mainly engaged in design of steel bridges. Since 1984 he has been teaching structural engineering at University of Utsunomiya.

SUMMARY

This paper presents results of fatigue tests for corroded steel plates. The test specimens with various degrees of corrosion were taken from an old bridge which had been used for over fifty years. It also deals with an attempt to predict the remaining fatigue life of steel railway bridges. For this purpose the author conducted fatigue tests of a steel railway bridge, which had been long in use and compared the test result with the analytical one.

RÉSUMÉ

Des essais de fatigue sur des tôles en acier corrodées sont présentés. Les échantillons, présentant différents degrés de corrosion, ont été prélevés sur un pont de plus de 50 ans. Les essais sont exécutés pour prédire la durée de vie restante. Les résultats sont comparés avec des solutions analytiques.

ZUSAMMENFASSUNG

Ermüdungsversuche an korrodierten Stahlblechen werden vorgestellt. Die Versuchskörper verschiedenen Korrosionsgrades wurden einer über fünfzigjährigen Brücke entnommen. Der Versuch wurde unternommen, um die Restlebensdauer vorauszusagen. Zu diesem Zweck werden die Versuchsergebnisse mit analytischen Ergebnissen verglichen.



1. INTRODUCTION

Steel bridges for railways are apt to suffer from fatigue damages. They are usually designed according to standards which take the fatigue effect into account and structural details which are supposed to have high resistance to fatigue failure are selected. Nevertheless, many fatigue damages have occurred in actual railway bridges and they are often associated with corrosion. While most available fatigue data for structures are those which are obtained from specimens of non-corroded materials, few data of fatigue tests conducted on steel members which have been corroded under natural circumstances are available.

The authors conducted fatigue test for the steel parts which had been cut off from an old railway truss bridge in use for over fifty years in Japanese National Railways. The test results revealed that the notch shape made by corrosion had a greater effect on the fatigue strength than the decrease of the sectional area due to corrosion, if it was not excessive.

The paper also deals with an attempt to estimate a cumulative fatigue effect analytically and compare it with the result obtained from an experiment on an actual railway plate girder bridge which was used for more than fifty years in one of the busiest trunk lines. The test result suggested, however, that the effect of cumulative fatigue damage was obscured by the effect of corrosion and the wide scatter of the test results in this example. It seems to difficult to predict the remaining life of a bridge accurately in this way in practice.

2. TEST ON CORRODED PLATES

2.1 Test Specimens and Procedures

The bridge from which the test specimens were cut off is Tenryu Bridge, a truss bridge constructed for Tokaido Line, one of the busiest trunk lines. It was erected in 1913 and had been used for about fifty years. In addition to specimens of standard coupon type, riveted specimens and shallow beam type bending specimens using the lower flanges of the stringers were also prepared as shown in Fig. 1. According to the static test conducted for mechanical properties of materials, the tensile strength of lower lateral members were a little inferior to those specified by JIS-SS 41 and ASTM-A 36, while the mechanical properties of other members were in conformity to the specifications. In the fatigue test the load was varied from nearly zero to the maximum tension.

Table 1 shows the outline of test series and summary of the test results.

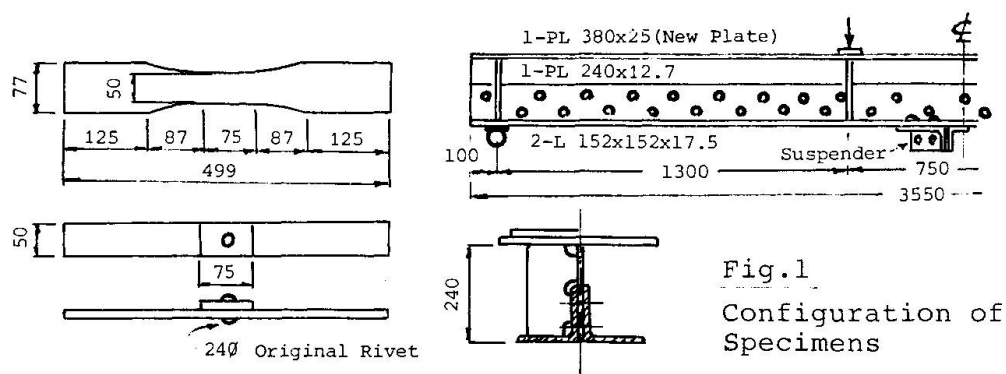

Fig.1
Configuration of
Specimens

2.2 Test Results

The test results are presented in Figure 2. As for the expression of the stress intensity for corroded specimens, three different ways were used; 1) the original cross-sectional area, 2) the average remaining cross-sectional area and 3) the area of the cross-section through which the rupture passed were referred to.

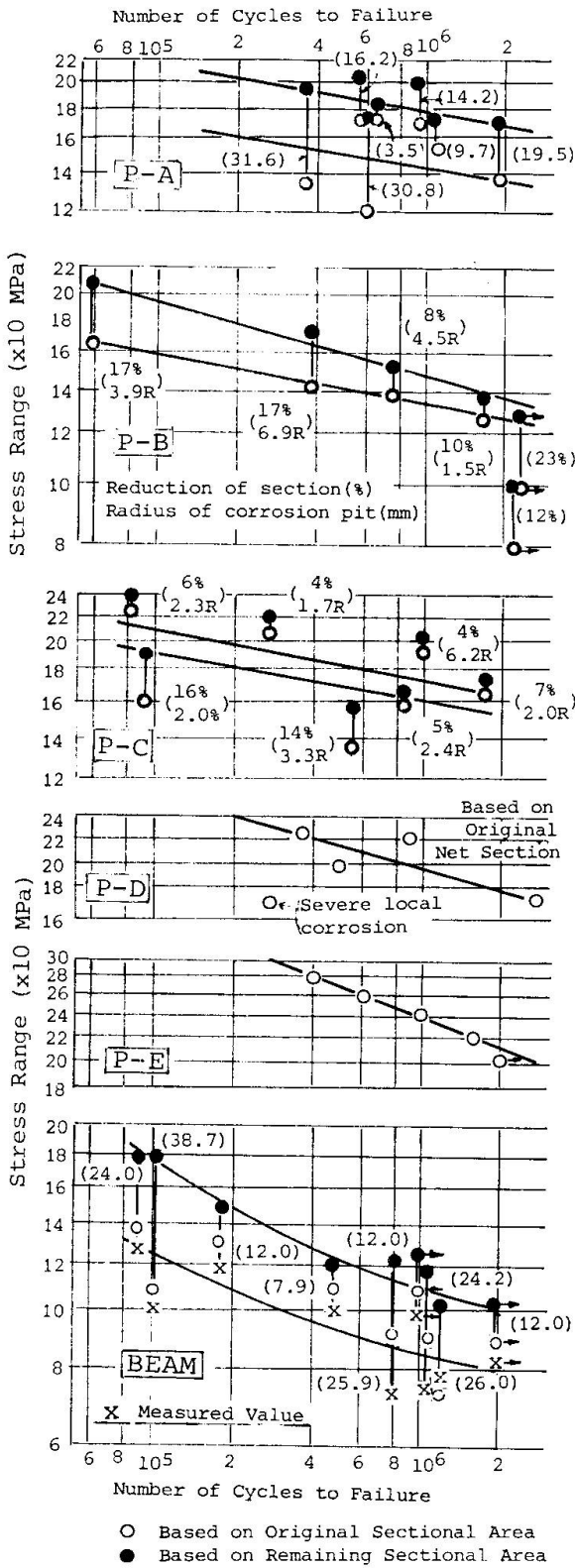

Fig. 2 Fatigue Test Results of Each Series

Furthermore, the radii of the corrosion pits from which the fatigue cracks started are also shown in the figures. For the bending test specimens, the stresses are expressed by three different ways, which are based on 1) the calculation according to the original non-corroded shape, 2) the measurement by wire strain gauges and 3) the values in inverse proportion to the reduction in the cross-sectional area due to local corrosion.

While the cracks were initiated at the bottoms of pits formed by corrosion in all the plate type specimens, they started from the edges of rivet holes in the riveted specimens and from the spot of the attachment for suspension of the lower lateral members in the beam type specimens. Several photos of fractured specimens also are shown.

2.3 Discussion

The data plotted in the figures are generally widely scattered. It is felt to be wider than in the cases of usual non-corroded specimens. The zero to tension fatigue strengths at two million cycles are summarized in Table 1. Assuming the fatigue strength of non-corroded plain plate with cut edge of 50 S as 250MPa on average, that of even a slightly corroded specimen is 210MPa (about 85%) and that of a heavily corroded specimen is drastically lowered down to 140 MPa (about 55%) even as expressed in reference to the remaining cross-section. The corroded riveted specimen, however, has a fatigue strength of 180 MPa, which is equivalent to the non-corroded riveted specimen. The reason for this seems that a riveted specimen has stress concentration inherently due to the rivet hole, which has the same degree of adverse effect on the fatigue strength as the surface irregularity due to corrosion and which need not be superimposed with the effect of corrosion.

In the beam type specimens, the fatigue strength is as low as 100MPa. It suggests that the corrosion adjacent to the attachment has a very adverse effect on the fatigue strength. It is natural that if the strength is evaluated in reference to the original cross-sectional area, it should be lowered furthermore. It seems that the



effect of the radius of the corrosion pit on the fatigue strength is insignificant.

Table 1 Specimens tested and fatigue strengths

Series	Corrosion	Location of Specimens	No.	Strength, MPa		
				1*	2**	
Plates	P-A	Severe	Lower flange of stringer	7	170	135
	P-B	Severe	Lower Lateral bracing for truss	6	135	125
	P-C	Slight	Upper lateral bracing for stringer	7	160	150
	P-D	Slight	Lower lateral bracing for truss ⁺	5	180	180
	P-E	Little	Web of stringer	5	210	210
Beam	Severe	Lower flange of stringer	7	100	80	

+) Specimens with rivets, *) Strength 1 is based on average cross-sectional area decreased by corrosion and **) Strength 2 is based on original cross-sectional area.

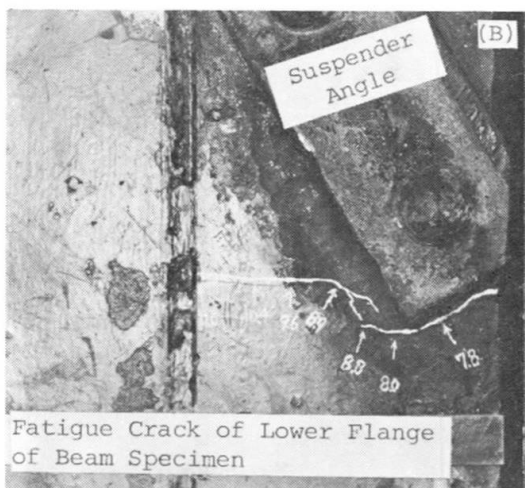
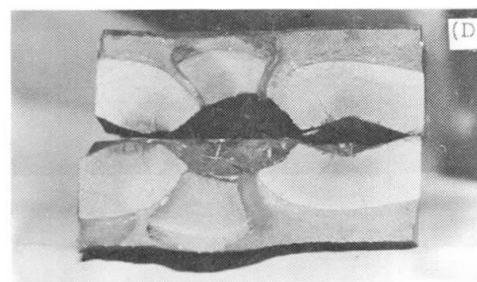
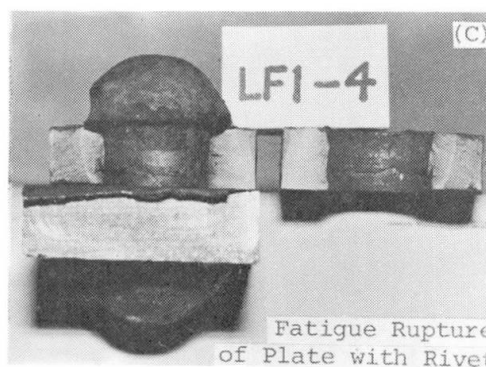
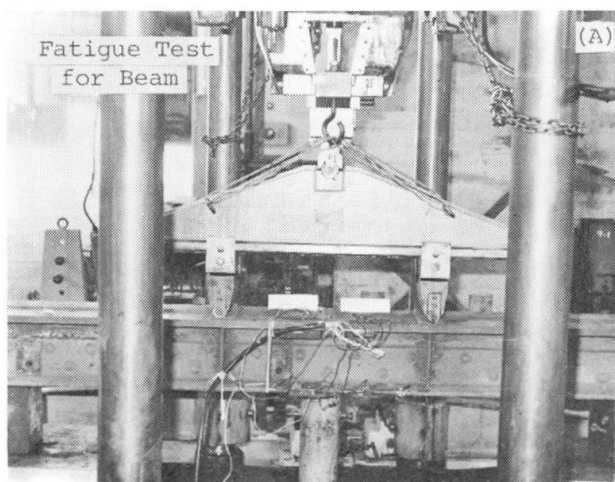

Fatigue Rupture of Heavily Corroded Plate

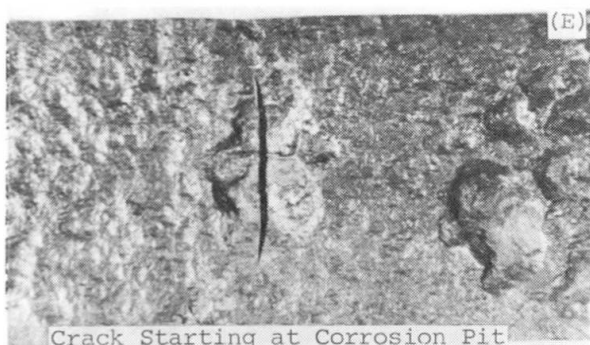

3. TEST FOR CUMULATIVE FATIGUE DAMAGE

3.1 Test Specimens and Procedures

The bridge which was used for investigation of the cumulative fatigue effect was a plate girder bridge of a 12.9 meter long span, used for 54 years in To-



hoku Line, a relatively busy trunk line. It was fabricated in U.S.A. and its material was produced in Carnegie Co. The specimens for fatigue test were cut off from the lower flanges of the plate girder. It was considered that the riveted parts of the lower flanges had suffered from the cumulative fatigue effect more severely than other parts because of the location and the stress concentration. For comparison, specimens were also taken from the less stressed parts and in some specimens the original holes were reamed, so as to remove the zone which was estimated to have been subjected to the most severe cumulative fatigue effect. According to the static test, the materials were in conformity with JIS-SS 41 and ASTM-A 36. The loading was repeated at a rate of 500 cycles per minute from 12 MPa to the maximum tension in the fatigue test.

3.2 Test Results

Fig. 3 shows the comparison of the results of specimens of plain machined plate, and specimens with rivet holes that were supposed to have experienced three different degrees of cumulative fatigue effect. It is natural that the value of plain plate specimens is high. It shows that the difference among the values of specimens of different conditions are very small, as judged from the regression lines of respective series, though the results are widely scattered.

3.3 Calculation of Cumulative Fatigue Effect

Table 2 shows the calculated stress, the number of stress cycles and the estimated cumulative fatigue effect for each of the eras when the types of locomotives crossing the bridge were recorded to be different. The cumulative effect was evaluated according to Miner's Law and the stresses around the rivet holes were assumed to be 1.9 times as large as those in the non-riveted parts as seen in Fig. 3. The coefficients of cumulative fatigue effect were, thus, determined as 0.288 and 0.010 for the parts subject to larger stress and those subject to smaller stress, respectively. In Fig. 3, the three theoretical lines thus obtained are drawn together with the test results.

The difference of remaining fatigue life due to the difference of experienced stresses (Series 5 and 6) in the present case is insignificant as seen from the theoretical lines. The effects of corrosion and quality of rivet holes caused the test results to scatter over a very wide range. For those reasons it was found to be practically difficult to clarify the difference of remaining fatigue life due to the cumulative fatigue effect.

4. CONCLUSIONS

(1) Even slight corrosion has a significant effect on the fatigue strength, especially in case the original element is smooth, free from stress concentration.

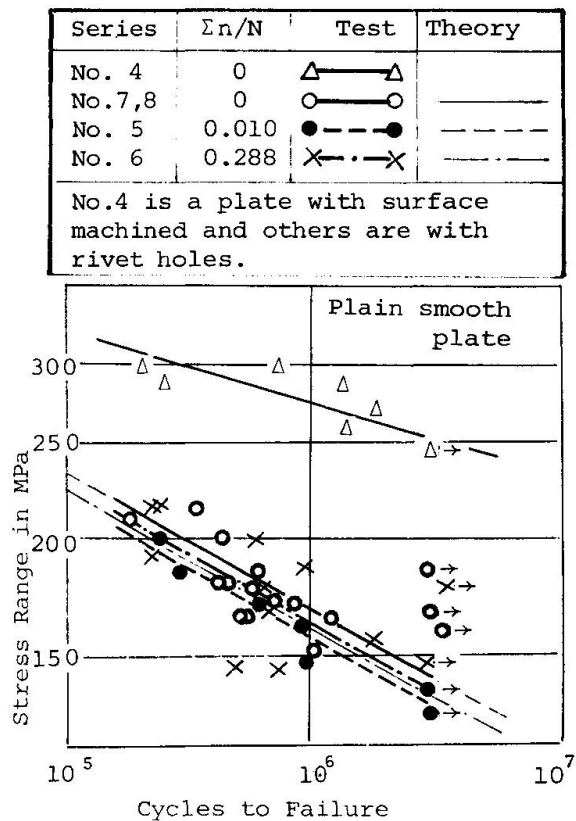

Fig.3 Results of Fatigue test of Cumulative Damage



When the allowable fatigue strength is to be determined for the design where such elements are used, care must be taken so as to provide a greater safety margin, assuming a possibility of future corrosion to some extent.

In a heavily corroded steel plate, the fatigue strength is drastically lowered to as low as 140 MPa to 100 MPa in reference to the remaining cross-sectional area, of stress range at two million cycles, because of severe stress concentration at the corrosion pit and because of reduction of the cross-sectional area. But the fatigue strength of elements which involve stress concentration inherently, such as riveted plates, are relatively less influenced by corrosion.

(2) According to an experiment on specimens cut off from a steel railway bridge which had been subjected to even considerably frequent loadings in the past, the cumulative fatigue effect on the remaining life appeared insignificant in practice. One of the reasons for this seems that the corrosion and irregularity in fabrication tend to cause such a vast scatter in the results of fatigue test that it is difficult to clarify the effect of the cumulative fatigue damage. The other reason may be that actually the cumulative effect on the main members or bridges which are carefully designed according to the current specifications is usually insignificant. Most of the actual fatigue failures have occurred at inadequate structural details, parts which have substantial defects in fabrication or hidden excessive corrosion, and have resulted from causes that had not been considered, when designed, such as repetition of out-of-plane deformation and vibration [1][2].

Table 2 Example of Calculation of Cumulative Fatigue

Period (1900)	More Stressed Part				Less Stressed Part			
	Stress (M Pa)	n_i (x1000)	N_i	n_i/N_i	Stress (M Pa)	n_i (x1000)	N_i	n_i/N_i
17 -19	112.7	132	2,592	0.051	74.5	132	79,782	0.002
31 -45	129.4	183	1,657	0.110	86.2	183	47,276	0.004
46 -58	120.5	153	2,084	0.073	80.4	153	58,558	0.003
59 -63	103.9	50	3,377	0.015	69.6	50	102,747	0.000
64 -71	103.9	130	3,377	0.038	69.6	130	102,747	0.001
Ditto	51.9	43	32,013	0.001	34.3	43	893,299	0.000
Sum/54		691		0.288		691		0.010

5. REFERENCE

- [1] H. ABE and A. TANIGUCHI, Fatigue Damage and Repair of Floor Beam of Steel Railway Bridges, Proc. of ASCE-IABSE Symposium at Morgantown, U.S.A., August 1980, pp 414 to 421
- [2] H. ABE et al., Fatigue Damage and Repair of Steel Railway Bridges in Japan, Final Report of IABSE Symposium at Tokyo, September 1986, pp 48 to 51