

Zeitschrift: IABSE reports = Rapports AIPC = IVBH Berichte
Band: 64 (1991)

Artikel: Design and construction of Tomei-Ashigara bridge
Autor: Kazama, Toru / Imai, Yoshiaki / Koizumi, Mitsumasa
DOI: <https://doi.org/10.5169/seals-49308>

Nutzungsbedingungen

Die ETH-Bibliothek ist die Anbieterin der digitalisierten Zeitschriften. Sie besitzt keine Urheberrechte an den Zeitschriften und ist nicht verantwortlich für deren Inhalte. Die Rechte liegen in der Regel bei den Herausgebern beziehungsweise den externen Rechteinhabern. [Siehe Rechtliche Hinweise.](#)

Conditions d'utilisation

L'ETH Library est le fournisseur des revues numérisées. Elle ne détient aucun droit d'auteur sur les revues et n'est pas responsable de leur contenu. En règle générale, les droits sont détenus par les éditeurs ou les détenteurs de droits externes. [Voir Informations légales.](#)

Terms of use

The ETH Library is the provider of the digitised journals. It does not own any copyrights to the journals and is not responsible for their content. The rights usually lie with the publishers or the external rights holders. [See Legal notice.](#)

Download PDF: 30.03.2025

ETH-Bibliothek Zürich, E-Periodica, <https://www.e-periodica.ch>

Design and Construction of Tomei-Ashigara Bridge

Etude et construction du pont Tomei-Ashigara

Entwurf und Ausführung der Tomei-Ashigara Brücke

Toru KAZAMA

Civil Engineer
Japan Highway Public Corp.
Tokyo, Japan

Mitsumasa KOIZUMI

Civil Engineer
Japan Highway Public Corp.
Matsuda, Japan

Souji KANAI

Civil Engineer
Taisei Corporation
Ashigara, Japan

Yoshiaki IMAI

Civil Engineer
Taisei Corporation
Ashigara, Japan

Toshio ICHIHASHI

Civil Engineer
Taisei Corporation
Ashigara, Japan

SUMMARY

Tomei-Ashigara Bridge was constructed as a part of the reconstruction project of the Tomei Expressway which is one of Japan's most important trunk roads. It is a 3-span continuous prestressed concrete cable-stayed bridge having a length of 370 m. As the bridge was to be located at a scenic place with a beautiful view of Mt. Fuji, the design involved a variety of aesthetic problems. In addition, the seismic study, aero-dynamic study, and model experiments were carefully carried out, and a number of devices were introduced to reduce the construction period. This paper reports the features in design and construction of the bridge.

RESUME

Le pont Tomei-Ashigara a été réalisé à la suite du projet de reconstruction de la voie express Tomei, qui est une des plus importantes routes nationales. D'une longueur de 370 m, ce pont haubané en béton précontraint comporte 3 travées continues. Etant donné qu'il se trouve en un lieu offrant une vue merveilleuse sur le Mont Fuji, le projet a dû tenir compte de divers problèmes esthétiques et, outre, réaliser avec soin une étude sismique, une étude aérodynamique et des essais sur maquette, ainsi que prévoir un certain nombre de dispositifs en vue de réduire la durée de mise en œuvre. Le présent article expose les caractéristiques du projet et de la construction de ce pont.

ZUSAMMENFASSUNG

Die Tomei-Ashigara Brücke wurde im Zuge der Modernisierung des Tomei-Expressways, eine der wichtigsten Hauptverkehrsadern in Japan, errichtet. Es handelt sich um eine über drei Felder durchlaufende Spannbeton-Schrägseilbrücke von 370 m Länge. Wegen ihrer herausgehobenen Lage an einem Aussichtspunkt mit besonders schönem Blick auf den Mt. Fuji waren einige ästhetische Probleme zu lösen. Der Entwurf umfasst Studien zum seismischen und aerodynamischen Verhalten, Modellversuche und Vorkehrungen zur Verkürzung der Bauzeit.



1. GENERAL VIEW OF THE BRIDGE

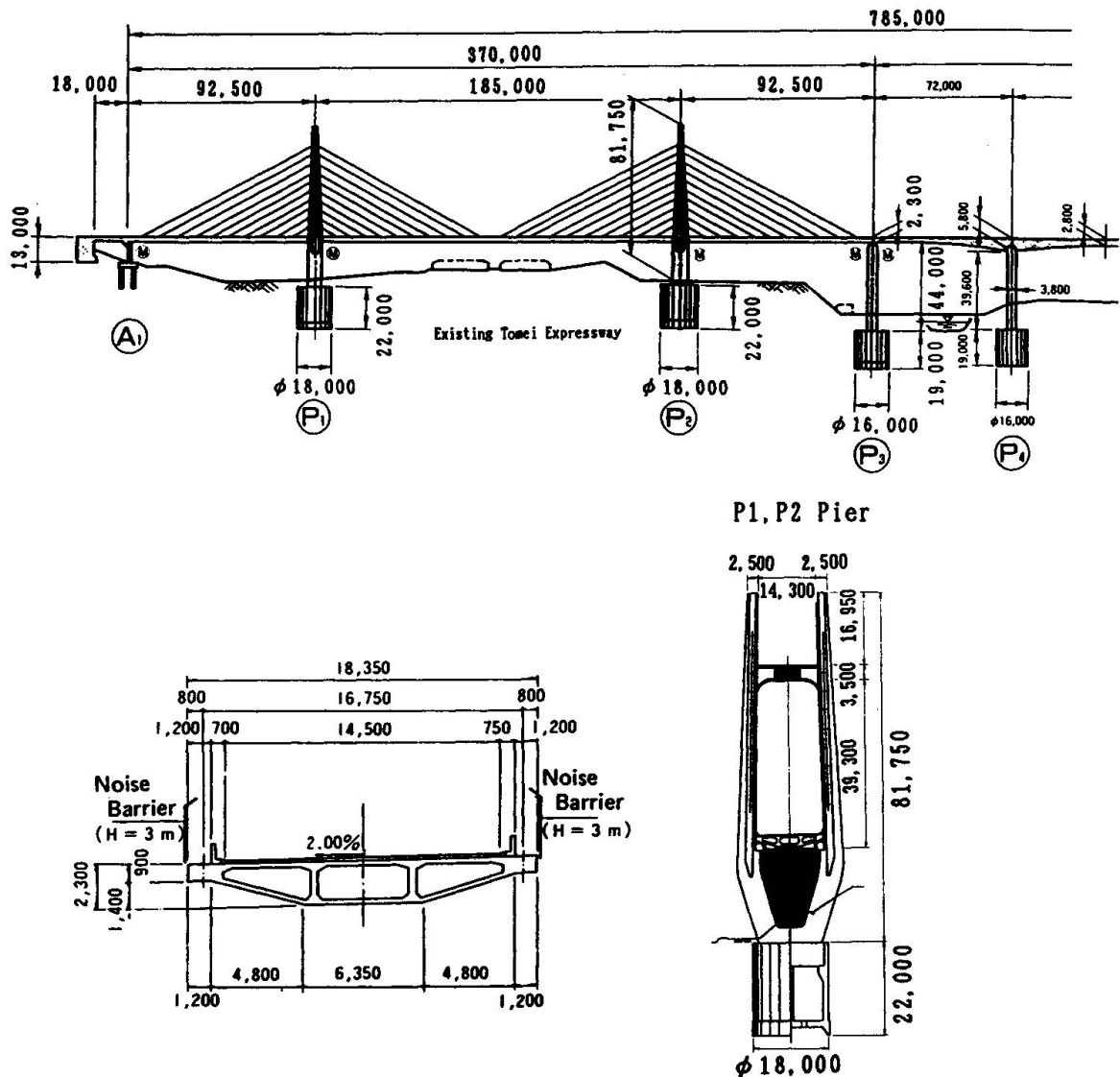

Fig.1 Elevation and typical cross section

2. CONSIDERATION IN DESIGN

2.1 Aesthetic Design

As the bridge passes over the existing Tomei Expressway, the aesthetic aspect was examined with emphasis on giving least sense of oppression to running vehicles. In particular, the bridge was to intersect the existing Tomei Expressway at a sharp angle of 26° , two piers would be seen like pressing ahead from the passengers running on the current highway. As the pier is a massive concrete block with a crown width of about 25m, a lower end width of 15m, and a thickness of 6.5m, various approaches were made so that it would look as slender as practicable. For the result, by introducing curves in the section, a feeling of softness was provided, and by extending wavelike stripes to beneath the girder, there was produced a dense space on the large surface to give an effect similar to that of a relief.

Also, the tower had two segments slightly tilted to the inside and the section reduced to upward and further, vertical grooves extending to the top, and thus it was possible to give a tight impression as a whole. Moreover, by coloring the grooves in sky blue, the effect was enhanced.

As the strut at the middle stage of the tower strongly appeals to the drivers running on the bridge, it was desired to give a feeling of release. Thus the hunch was designed with a smooth curve, and the central part of the strut was reduced to 3.5m in height. Also, at the central part, stripes similar to those on the pier were provided, while on the lower surface of the strut, grooves continuing from the tower were carved, so that the strut would look as slender as practicable.

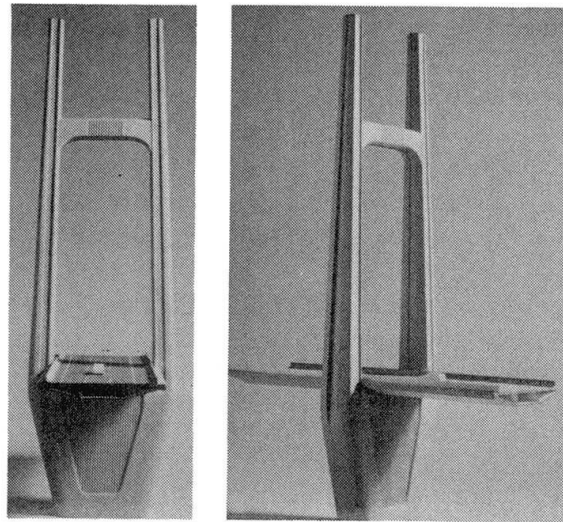

Fig. 2 Tower model

2.2 Seismic Study

The bridge is located in one of the intensive earthquake zones in "Earthquake Island Japan" and is included in an "Earthquake Disaster Prevention Area." Also, the bridge is located at a key point of the Tomei Expressway which is a main artery for transportation of materials, and so it must have the function highly maintained in the event of an emergency or disaster. In view of the foregoing, the aseismatic design was made according to the following principles.

(1) Dynamic analysis according to the response spectra

The sections of the members were designed according to the allowable stress intensity method and ultimate strength theory so that each member maintains required yield strength and produces no excessive deformation against earthquakes occurring at a certain probability during the service period.

(2) Elasto-plastic time history response analysis

Assuming a large-scale earthquake that may occur during the service period, it was verified that the structural system has a required yield strength and ductility. The analysis was made with an acceleration wave form assuming a Tokai Earthquake.

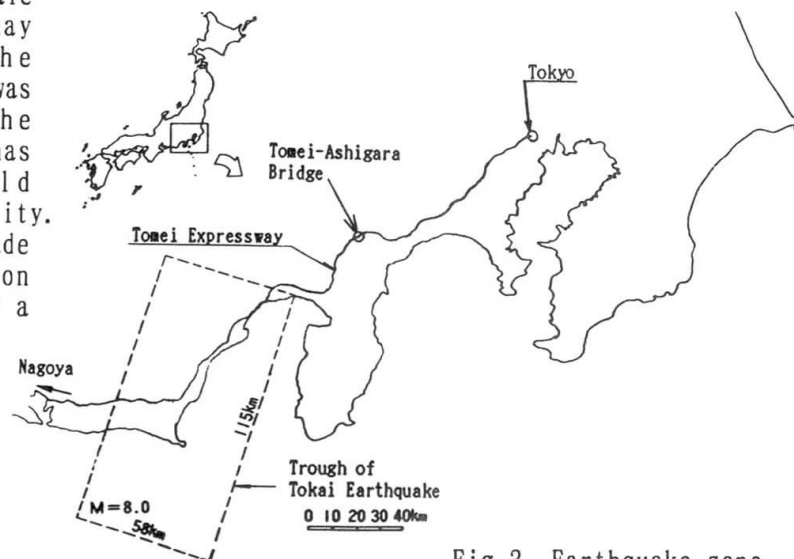

Fig. 3 Earthquake zone



2.3 Other Examinations

As other items to be particularly examined, the following may be cited.

(1) Aero-dynamic study

a) Wind survey : Measurement of the wind directions and speeds at the site.

b) Wind tunnel tests:

Sectional model —Examination made particularly for the effects of noise barrier

Full model —Examination of the aero-dynamic behavior of the whole bridge

Cable model —Examination of the rain vibration.

(2) Model tests for establishing the design method

a) Torsional tests with a partial model of the tower (scale:1/4)

- Establishment of the design method for a torsional moment acting to the complex sectional form of the tower.

b) Full model tests (scale: 1/2)

- Reinforcement of cable anchorages
- Flow of stress in girder

Details are omitted here. For more details, see the reference No.3.

3. CONSTRUCTION WORK

3.1 Amount of Major Materials

The construction work of the bridge had an overall order issued inclusive the earthwork, foundation work, substructure work and superstructure work. The amount of the major materials of the bridge is shown below.

• Concrete	Caissons, abutments	9,600 m ³
	Piers, towers	8,600 m ³
	Girder	5,900 m ³
• Reinforcing bars		3,300 t
• Prestressing steels		380 t
• Stay cables (HiAm anchorage cable)		260 t
• Earthwork		96,000 m ³
• Slope pavement		16,000 m ³

3.2 Work Schedule

The Tomei Expressway reconstruction work had a social requirement to complete the section including this bridge by March 1991. However, it was 7 months after the initial schedule that the work could be started, and so various rapid work processes were incorporated.

3.3 Pier Work

The pier work period was reduced by the following two work methods in order to start the girder work as soon as possible.

(1) As the pier was designed as a steel framed reinforced concrete (SRC) structure, the work of the girder on the segment on the pier, and concrete placement of the pier were carried out in parallel just after the steel frame was set up. (See fig.4)

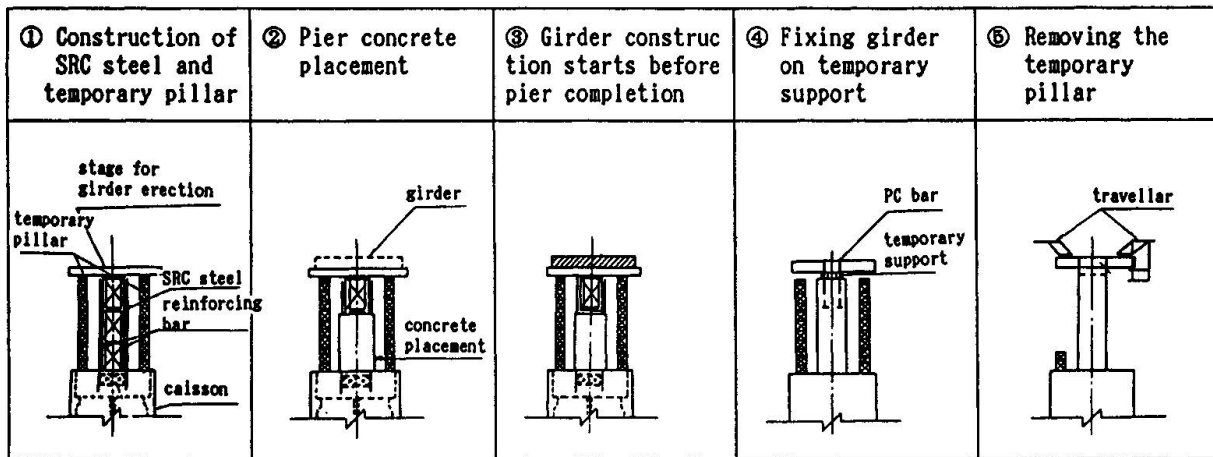

Fig. 4 Pier construction method

(2) The concrete placement height for each block was increased to reduce the number of lifts, and maximum 1,200m³ of concrete was placed continuously in a lump day and night.

By the foregoing two methods, 2 months were reduced for the work period.

3.4 Girder and Tower Works

From the locational condition of the bridge, the girder work method was limited to the means of cantilever cast in place construction. To reduce the work process as much as possible under such restriction, the following processes were adopted.

(1) Simultaneous work of girder and tower

The bridge comprises a plane alignment ($R=2,000m$), and the horizontal component of force of the cable tension in a direction perpendicular to the bridge acts as to tilt the tower toward the inside of the curve. To resist such force, the strut on the tower assumes a very important role. But there was not enough time to wait completion of the tower before commencement of the girder work, two stages of temporary struts were settled, so the work of the girder was done simultaneously with that of the tower.

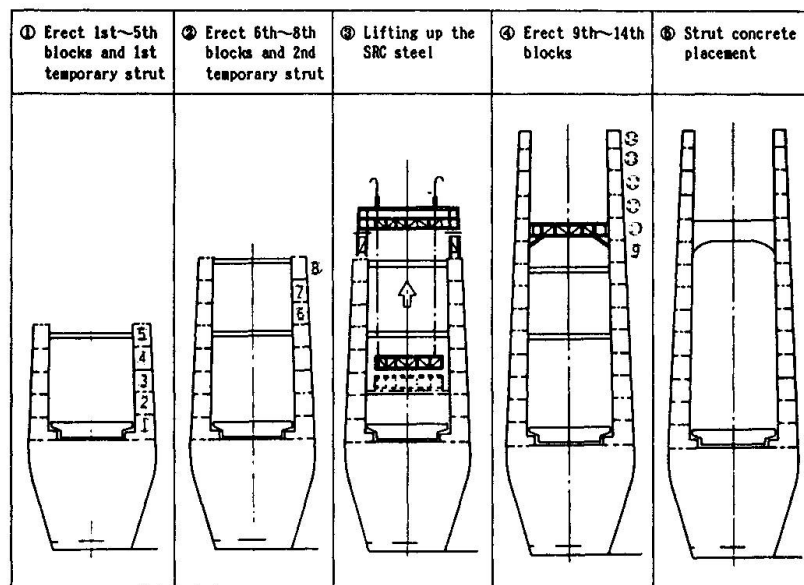

Fig. 5 Tower construction method



(2) Post-working of the strut

The strut work would constitute a critical path for the works of girder and tower, and so the strut was constructed as to be capable for resisting the external force by the steel frame alone at the time of installation, and the concrete cast work was done after whole other works for the tower were completed.

3.5 Protection for The Existing Tomei Expressway

The existing Tomei Expressway has as much a traffic volume as about 60,000 cars a day, and fall of the construction materials onto the cars running at a high speed may result in a serious accident. In addition to complete protection of the travellers, a guard roof was settled over the current expressway for the length of 120m as a second safety measure. The roof was made of 48 steel truss girders, which the length of 30m and a width of 2.35m, were arranged in parallel on supports constructed on the shoulders of the existing Tomei. This work was made at night when the traffic of the existing Tomei Expressway was suspended from 6:00 o'clock in the afternoon to 7:00 o'clock in the next morning.

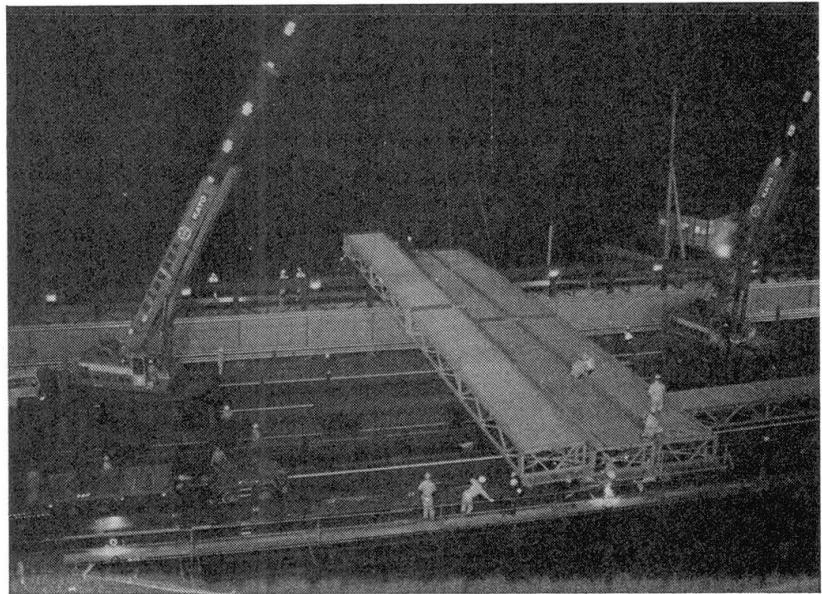

Fig.6 Protection of existing expressway

4. POSTSCRIPT

The construction has completed in March 1991, and now we can see this monumental structure with automobiles running in full speed and beautiful background "Fuji Yama". It was very fortunate that we could have a precious chance to make a great deal of studies for design and construction, and further we hope that these experiences will be also useful to other bridges in future. We truly appreciate the effort which designer Sori Yanagi has made for aesthetic design, also thank to the members of the "Construction Committee" (Dr. Manabu Ito as a chairman) and to all persons concerned.

REFERENCES

1. Kurasawa, Furukawa, Kitagawa : The Plan and Study of Tomei-Ashigara Bridge. The Bridge, January 1987, In Japanese.
2. Kimura, Ohta, Kanai, Tomita, Sadamitsu : Construction of Tomei-Ashigara Bridge. The Bridge and Foundation, September 1990, In Japanese.
3. Kadotani, Ohta, Kumagai, Imai : Noticeable Features on Design of Tomei-Ashigara Bridge. The Bridge and Foundation. February, March 1990, In Japanese.
4. Seki, Tanaka, Ichihashi : Development of High Performances Construction Control System for Prestressed Concrete Cable-Stayed Bridges, Innovation in Cable-Stayed Bridge, April 1991.