

**Zeitschrift:** IABSE reports = Rapports AIPC = IVBH Berichte  
**Band:** 64 (1991)

**Artikel:** Bridges of increased seismic stability  
**Autor:** Shestoperov, G.S.  
**DOI:** <https://doi.org/10.5169/seals-49263>

### **Nutzungsbedingungen**

Die ETH-Bibliothek ist die Anbieterin der digitalisierten Zeitschriften. Sie besitzt keine Urheberrechte an den Zeitschriften und ist nicht verantwortlich für deren Inhalte. Die Rechte liegen in der Regel bei den Herausgebern beziehungsweise den externen Rechteinhabern. [Siehe Rechtliche Hinweise.](#)

### **Conditions d'utilisation**

L'ETH Library est le fournisseur des revues numérisées. Elle ne détient aucun droit d'auteur sur les revues et n'est pas responsable de leur contenu. En règle générale, les droits sont détenus par les éditeurs ou les détenteurs de droits externes. [Voir Informations légales.](#)

### **Terms of use**

The ETH Library is the provider of the digitised journals. It does not own any copyrights to the journals and is not responsible for their content. The rights usually lie with the publishers or the external rights holders. [See Legal notice.](#)

**Download PDF:** 18.03.2025

**ETH-Bibliothek Zürich, E-Periodica, <https://www.e-periodica.ch>**

## Bridges of Increased Seismic Stability

Ponts offrant une résistance antisismique élevée

Brücken mit erhöhter Erdbebensicherheit

### G. S. SHESTOPEROV

Bridge Engineer  
TsNIIS  
Moscow, USSR



German S. Shestoperov, born in 1941, licensed bridge construction engineer and mathematician, candidate of sciences, engaged in research into seismic stability of bridges and dynamics of structures. Presently employed by Central Research Institute of Transport Construction (TsNIIS).

### SUMMARY

The report presents the estimated data concerning the vulnerability of bridges to earthquakes, defines the range of application of special antiseismic devices, specifies the principal characteristics of standard superstructures, of bulky piers employed for the construction of bridges in seismic regions of the USSR. The report also considers various designs of bridge antiseismic devices, their technical and economic features.

### RESUME

Le rapport traite de la vulnérabilité des ponts lors de tremblements de terre et définit le domaine d'application des dispositifs antisismiques spéciaux. Il mentionne les principales caractéristiques des éléments-types, des travées ainsi que des piles de ponts massives et légères utilisées dans la construction des ponts dans les régions de sismicité élevée de l'URSS. Le rapport présente les caractéristiques de projet et les performances technico-économiques des dispositifs antisismiques des ponts.

### ZUSAMMENFASSUNG

In diesem Vortrag wird die Erdbebengefährdung von Brücken und der Anwendungsbereich antiseismischer Sonderausrüstung beurteilt. Vorgestellt werden die Hauptmerkmale der typisierten Tragwerke und Pfeiler (in massiver und leichterer Ausführung), die beim Bauen der Brücken in den erdbebengefährdeten Gebieten der UdSSR angewendet werden. Es werden die Konstruktionen und die technisch wirtschaftlichen Daten der antiseismischen Ausrüstungen der Brücken betrachtet.



## 1. VULNERABILITY OF BRIDGES TO EARTHQUAKES

There are numerous methods of protecting the bridges against earthquakes and their further development is stimulated by heavy damage done to bridge constructions as a result of earthquake shocks. Therefore, before considering specific design features of the bridges with higher seismic stability it is advisable to estimate the vulnerability of these structures to seismic effects with intensity of 7 to 10 points (MSK scale).

During the period of last twenty years the field work in the earthquake epicentral areas of the Soviet Union included the examination of more than one hundred bridges the service life of which on the date of the examination was ranging from one year to one hundred years. Of all the bridges examined 60 per cent were highway bridges and 40 per cent - railway bridges. They were represented by bridges over rivers and canals, viaducts, flyovers including the beam, frame, arch and suspension bridges.

Out of the total number of the bridges examined 30 per cent were found earthquake-damaged. Usually the seismic effects caused cracks in the abutment wing walls and parapet walls, in the concrete under the shoes and in the columns of the piers. Often the damage consisted in drift of roller, inclination of the rolls in the movable supports, displacement of abutments towards the bridge middle, limited shifting of simple and continuous beam structures in plan.

The most heavy damages were detected in railway and highway bridges after the earthquake in Armenia (1988) with an intensity of 9 to 10 points. An illustrated report about the consequences of this earthquake presented to the symposium also contains the information about the damaged structures.

The difference of engineering and geological conditions, variety of the properties of the materials employed, multitude of the design and constructional features of the carrying structures result in a great variety of seismic damages done to the bridges. Nevertheless the date of the examinations made in the USSR, USA, Japan and other countries make it possible to single out certain characteristic forms of damage and destruction in the case of the bridges without adequate antiseismic protection (see Table 1).

It must be pointed out that only qualitative estimates of the damages can be offered since the examination data are not complete enough. In some individual cases (in unfavourable soil conditions, unstable slopes, previously-damaged structures and the like) the characteristic damages may be detected after earthquakes with an intensity one or two points below that specified in Table 1. On the other hand, due regard for the principles of the seismic-resistant construction and for the specified antiseismic measures can make the damages one or two grades lower than those indicated in the Table 1.



| Points of MSK-64 scale | Characteristic damages of bridges  |
|------------------------|--|
| 7                      | <p>Local deformations</p> <p>Cracks in bridge stone structures. Checks and spalling of protective concrete layer in the reinforced concrete piers</p>  |
| 8                      | <p>General deformations</p> <p>Displacement of abutments towards the bridge middle. Settlement and inclination of piers which are based on soft ground. Drift of rollers and inclination of rolls in movable supports</p>                  |
| 9                      | <p>Strength disturbances</p> <p>Fractures in stone and plain concrete structures. Severe damage to the shoes, abutment parapet walls, pad stones and beam ends</p>   |
| 10                     | <p>Stability disturbances</p> <p>Shifting and overturning of the stone and plain concrete piers. Overturning of the viaduct piers constructed as reinforced concrete columns. Falling down of the simple beams and slabs on the ground</p> |

Table 1 Vulnerability of bridges to earthquakes

The data of the examinations make it possible to define the field of applying the seismic stability analyses and special antiseismic devices of the bridges as follows: a) the carrying capacity of the structures should be analyzed for earthquakes with an intensity of 7 points and over; b) for the estimated seismicity of 9 points, the use of the special antiseismic devices should be a mandatory practice; c) for the estimated seismicity of 7 and 8 points the employment of the special antiseismic devices could be left to the designer's own judgement.

During the past two decades large-scale railway construction was in progress in East Siberia. Nearly 1000 bridges have been built in the areas of seismic shocks ranging from 7 to 10 points. Some large railway and highway bridges were constructed in other seismic areas of the USSR. Measures to ensure the seismic stability of the bridge superstructures and piers were taken during the construction of the new bridges in accordance with the Building Code [1] requirements. Considered below are some examples of seismic-resistant bridges and main characteristics of their antiseismic devices.



## 2. BRIDGE SUPERSTRUCTURES OF HIGHER SEISMIC STABILITY

The experience of operating bridges in seismic areas shows that the most efficient measures of ensuring the seismic stability of the bridge framework are: smaller mass of the bridge superstructure, stronger supporting structures and use of special antiseismic devices. In any case, the design of the earthquakeproof immovable support parts should provide for the transfer to the support of the seismic load acting on the superstructure longitudinally and laterally relative to the bridge axis. The earthquakeproof movable supporting parts must transfer the lateral seismic load while ensuring unimpeded travel of the superstructure movable end in the process of seismic vibration [2].

The design of the antiseismic devices must prevent the uplifting of the beam supporting units, shifting and upsetting of the superstructures while being capable of damping the impacts of the superstructures against each other and against projecting parts of the piers (parapet walls, stoppers). Besides, the function of the antiseismic devices is to prevent the simple beam superstructures from collapsing in case of a shift along a tectonic fracture crossing the bridge overpass axis.

In the bridge construction practice of the USSR the spans of over 18 m are bridged by means of steel and steel-reinforced beam framework. Besides with the spans ranging from 15.8 to 26.9 m the designers use simply supported structures manufactured from prestressed reinforced concrete.

The prestressed superstructures are designed on ballast for the bridges and viaducts constructed on straight-line and curved sections of the road. The concrete is of the M400 rank selected according to compression strength. The stressed reinforcement is made of steel wire with a diameter of 5 mm and resistance of 1700 MPa. The superstructure beams mounted on their supporting parts are interconnected by means of field joints on the transverse diaphragms. The main data of the prestressed superstructures are presented in Table 2.

| Overall length, m | Design span, m | Constructional depth, m | Permanent load on 1 m of track, kN |
|-------------------|----------------|-------------------------|------------------------------------|
| 16.5              | 15.8           | 1.90                    | 92                                 |
| 18.7              | 18.0           | 2.05                    | 104                                |
| 23.6              | 22.9           | 2.35                    | 112                                |
| 27.6              | 26.9           | 2.76                    | 114                                |

Table 2 Characteristics of railway bridge superstructures from prestressed reinforced concrete

The mould dimensions and the reinforcement of the prestressed earthquakeproof beams are the same as in the case of plain beams. Used as antiseismic parts of the earthquakeproof superstructures

are their plate joints preventing the shifting of one beam relative to the other in plane during the earthquake and the angles keeping the pavement plates in place. To prevent the dislocation of the movable supporting parts, their hinges are provided with higher flanges. The shear of the superstructure across the road axis is limited by the reinforced concrete stoppers mounted on the underframe plates at the side of the bridge superstructure (see Fig. 1).

The expenditure of the materials required for the construction of

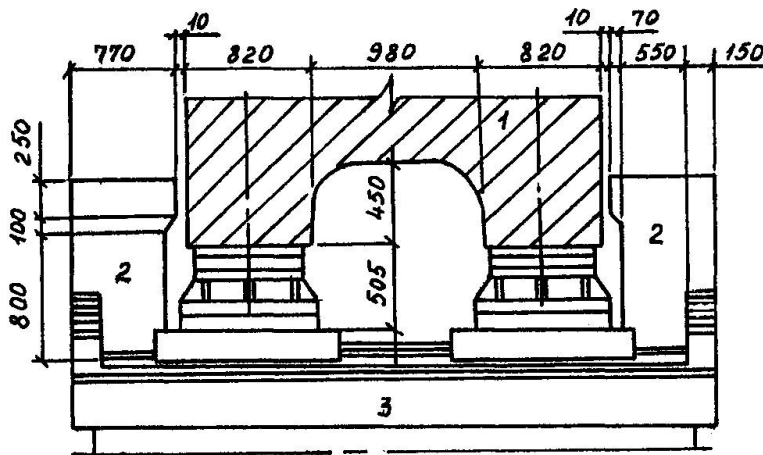

the devices protecting the bridge superstructures from the prestressed reinforced concrete from the falling down under the action of the seismic forces depends on the length of the superstructure. The mass of the concrete required by the reinforced concrete stoppers is 2,0 to 2,6 m<sup>3</sup> per one intermediate pier and the mass of the reinforcement from 0,28 to 1,16 t. If the local conditions are favourable the height of the stoppers and, consequently, the material expenditure may be lower.

Fig.1 Stoppers protecting bridge superstructures with spans of 23.6 and 27.6m against lateral shifts: 1-bridge superstructure; 2-reinforced concrete stopper; 3-abutment

To bridge the spans ranging from 18,2 to 55 m, use is frequently made of standardized superstructures made of steel-reinforced concrete. Among the advantages featured by the particular bridge superstructures are their capability of being employed on the road curved sections and comparatively good protection of the main beams from the effects of the atmospheric precipitation. However, the standardized structures have a considerable own weight, their center of gravity is high-positioned relative to the supporting parts and the labour expenditure connected with their erection is great. According to the permanent load per 1 m of the track (see Table 3) the

| Overall length, m | Design span, m | Constructional depth, m | Permanent load on 1 m of track, kN |
|-------------------|----------------|-------------------------|------------------------------------|
| 18,8              | 18,2           | 2,19                    | 82                                 |
| 23,6              | 23,0           | 2,44                    | 82                                 |
| 27,6              | 27,0           | 2,94                    | 84                                 |
| 34,2              | 33,6           | 2,97                    | 86                                 |
| 45,8              | 45,0           | 4,86                    | 99                                 |
| 55,8              | 55,0           | 4,91                    | 103                                |

Table 3 Characteristics of railway bridge superstructures from metal beams combined with reinforced concrete plate





reinforced-steel structures occupy an intermediate position between the reinforced concrete and steel structures.

The manufacture of the earthquakeproof steel-reinforced superstructures requires the same materials which are used for plain structures. The main beams, plates and links are also of the same design. In the case of estimated seismicity of 9 points only the supporting parts of the superstructures with a length of 34,2 and 45,8 m are to be strengthened. Besides, the earthquakeproof superstructures must be secured by stoppers preventing the shift of the beams across the track axis and by the vertical anchors to prevent the structure overturning and the beams from bouncing.

The bridge superstructures with a length of 18,8 to 34,2 m are secured at both ends by the middle sections of the jack beams. The anchor is constructed as a steel hinged part (see Fig.2). The mass

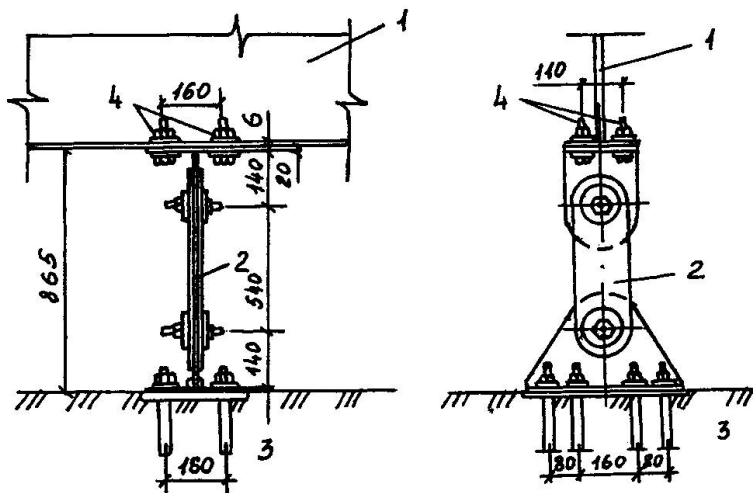

of the anchor metal is about 270 kg per one superstructure. The metal mass of the anchors for the superstructures 45,8 and 55,8 m long is about 1700 kg.

The own mass of the superstructures can be considerably reduced if use is made of the metal structures constructed as bottom-road truss with wooden joists (Table 4). Such structures are available for bridging the spans ranging from 33 to 110 m. If necessary, the seismic stability of the bridge su-

Fig.2 Anchor for bridge steel-reinforced superstructures with span of up to 34,2 m: 1 - jack beam of bridge superstructure; 2 - anchor; 3 - pier; 4 - high-strength bolts

perstructures is ensured by strengthening the supporting parts, as well as by the use of stoppers and anchors.

| Overall length, m | Design span, m | Constructional depth, m | Permanent load on 1 m of track kN |
|-------------------|----------------|-------------------------|-----------------------------------|
| 33,8              | 33             | 1,20                    | 38                                |
| 44,8              | 44             | 1,20                    | 38                                |
| 55,8              | 55             | 1,20                    | 39                                |
| 67,0              | 66             | 1,57                    | 40                                |
| 78,0              | 77             | 1,57                    | 44                                |
| 89,1              | 88             | 1,85                    | 49                                |
| 111,1             | 110            | 1,85                    | 54                                |

Table 4 Characteristics of railway bridge bottom-road superstructures

In seismic region use can also be made of the top-road bridge superstructures including the trusses with spans of 44,55 and 66 m. Such superstructures were used for a bridge erected as a design of 3x55 m during the construction of the Baikal-Amur railway line. The bridge site is crossed by a tectonic fracture 30 m wide. The rock in the area of the fracture has been crushed to the condition of gravel. The monolithic abutments and prefabricated monolithic construction intermediate piers are outside the crushing zone. The bulky foundations all piers rest on strong rock.

To allow for unfavourable tectonic conditions, some additional measures of the bridge overpass antiseismic protection were taken by the designers - the installation of combination, coupling and buffer devices on the bridge.

The combination devices (Fig. 3) prevent the shearing of the supporting units across the bridge axis and their uplifting.

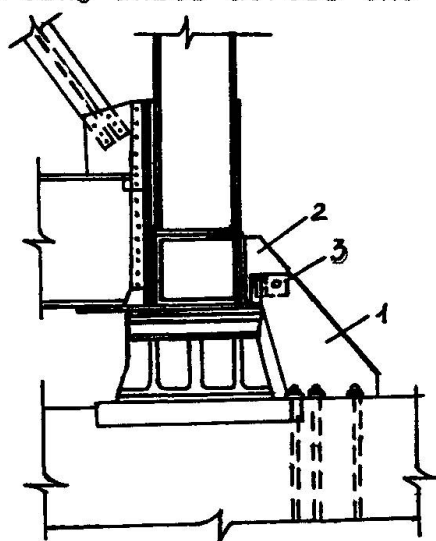

Fig.3 Combination device for truss 55 m long: 1 - lower stop; 2 - upper stop; 3 - pivot

The combination device comprises the lower stop connected with the pier by anchor bolts, upper stop attached to the truss by strong bolts and pivot with a diameter of 50 mm. The anchor bolts are embedded in the pier heads with the help of epoxy resin. The metal expenditure for the combination devices of one truss is about 1190 kg.

The coupling devices capable of withstanding the bearing reaction of the structure limit the relative vertical displacement of the adjacent ends of the neighbouring trusses. The coupling devices (Fig.4) are mounted by means of high-strength bolts. Each coupling device for the truss spans of 55 mm comprises the vertical plates, cross strips and pivot.

The bolt holes are drilled in the plates as required by the actual position of the superstructures. The pivot hole in the vertical plates of the coupling devices are made oval-shaped. The three-span bridge requires eight coupling devices (four of them in each of the upper and lower units above the intermediate piers).

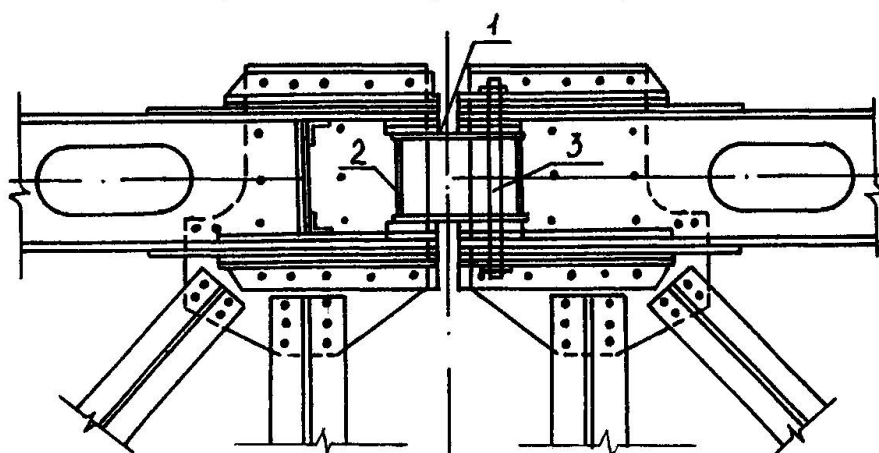

Fig.4 Coupling device: 1 - plate; 2 - strip; 3 - pivot

The total mass of the coupling devices is 1800 kg.

The purpose of the buffer devices is to buff the unfavourable effects of the trusses striking against the horizontal movement limiters. In the particular bridge the buffer devices are fitted into the be-





veled ends of the extreme trusses. Each buffer (Fig.5) is constructed as a bulky steel body to take the striking force and a set of disc springs on which the rear of the body head rests. The springs are enclosed in a metal housing that protects them against atmospheric precipitation and dirt. The

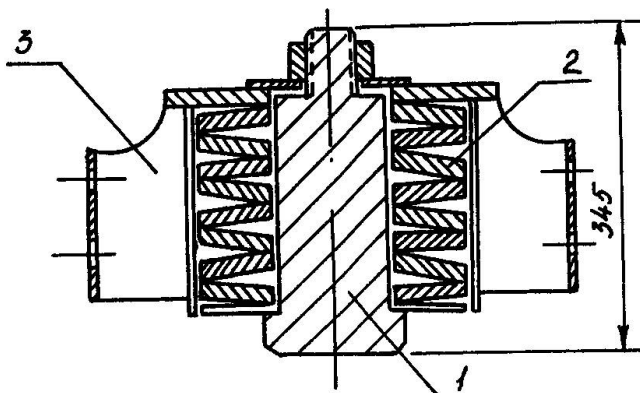

Fig.5 Buffer device: 1-bulky body; 2-disc spring; 3-housing

of the buffer device is attached to the truss unit sheets by means of high-strength bolts. The bridge employs four buffers with a total mass of 700 kg.

The above-discussed antiseismic devices are also employed by highway bridges.

### 3. PIERS OF HIGHER SEISMIC STABILITY

The experience of operating the bridges in seismic regions has revealed a number of important requirements to be met by the ground on which the bridge pier foundation must be rested, as well as by the foundations and pier upper parts. In particular, the piles, poles and casings must be sunk as deep as the ground unlikely to be deformed (rock, large stone, hard clay and the like). The friction piles must have a reserve of ground strength.

When constructing bridge piers in seismic regions it is a good practice to use the materials and structures that tolerate considerable development of inelastic deformation at the stage preceding the breakdown. Such structures are capable of withstanding considerable short-duration loads. Fair plasticity is featured by common and prestressed reinforced-concrete structures in the earthquake-proof version and, therefore their seismic stability is high enough.

High strength of reinforced concrete makes it possible to reduce considerably the own weight of the piers (in comparison with the concrete piers) thus lowering the seismic loads. This is particularly important for the estimated seismicity of 9 points when the cost of the materials required for the erection of the piers is rather high. Most frequently used in the USSR are the relieved piers constructed as flat and spatial reinforced concrete frames, as well as the prestressed hollow piers of the viaducts with a height of up to 50 m from prefabricated components. Use is also made of some other methods of ensuring the seismic stability of the bridge piers such as employment of higher-rank concrete, jointing of prefabricated-monolithic pier components by epoxy glue, structural reinforcement of the concrete piers during their erection in the areas with a seismicity of 7 and 8 points.



The expenditure of the materials for the antiseismic protection of the bridge piers depends on numerous factors (estimated seismicity, design of the piers, mass of the superstructures, etc.). In unfavourable conditions the expenditure of concrete and reinforcement can become 30 to 40 per cent larger. Nevertheless, the employment of the frame-type reinforced-concrete piers instead of the bulky ones can make the concrete expenditure 2 to 2,5 times lower.

#### 4. CONCLUSIONS

The bridge superstructures designed today in the seismic regions have sufficient strength margin to withstand most severe earthquakes. But sometimes the bridge designers neglect the principle of reducing the mass of the superstructures and this results in increased loads on the piers during earthquakes. The technical and economic characteristics of the bridges erected in seismic areas can be improved thanks to a wider use of the bridge superstructures with lower own weight.

Efficient earthquakeproof designs of the bridge piers have been developed including the plane and spatial-frame ones from plain reinforced concrete or hollow - from prestressed reinforced concrete. Nevertheless, the erection of bulky piers in seismic regions has not yet been discontinued despite considerable expenditure of the materials they require. To economize efficiently on the resources, the erection of the bridge piers in seismic regions must be based on new progressive design solutions.

The need for the transfer of the seismic forces directed horizontally and vertically complicates the construction of the supporting parts, makes them heavier. However, even the strengthening of the supporting parts cannot always ensure an adequate seismic stability of the bridge superstructures since the ground residual deformations caused by very severe earthquakes and disregarded in the calculation result in displacement the piers and breaking the bolts of the supporting parts. Therefore, when erecting bridges on sites with complicated geological and engineering conditions it is a good practice to have the superstructures secured by means of special antiseismic devices.

The design studies in the USSR show that the anchoring, coupling, buffer and combination antiseismic devices fit well the designs of the railway and highway bridge superstructures. The laboratory research and examination data justify the employment of the disc springs and rubber-and-metal devices as bridge seismic shock absorbers.

#### REFERENCES

1. Building code and standarts. Construction in seismic regions (SNiP 11-7-81). M., Stroyizdat, 1982.
2. Recommendations concerning seismic effects to be allowed for in bridge constructions. M., TsNIIS, 1983.

Leere Seite  
Blank page  
Page vide