

Zeitschrift: IABSE reports = Rapports AIPC = IVBH Berichte
Band: 67 (1993)

Artikel: Experimental investigation of traffic load on highway bridges
Autor: Sokolík, Andrej
DOI: <https://doi.org/10.5169/seals-51365>

Nutzungsbedingungen

Die ETH-Bibliothek ist die Anbieterin der digitalisierten Zeitschriften. Sie besitzt keine Urheberrechte an den Zeitschriften und ist nicht verantwortlich für deren Inhalte. Die Rechte liegen in der Regel bei den Herausgebern beziehungsweise den externen Rechteinhabern. [Siehe Rechtliche Hinweise.](#)

Conditions d'utilisation

L'ETH Library est le fournisseur des revues numérisées. Elle ne détient aucun droit d'auteur sur les revues et n'est pas responsable de leur contenu. En règle générale, les droits sont détenus par les éditeurs ou les détenteurs de droits externes. [Voir Informations légales.](#)

Terms of use

The ETH Library is the provider of the digitised journals. It does not own any copyrights to the journals and is not responsible for their content. The rights usually lie with the publishers or the external rights holders. [See Legal notice.](#)

Download PDF: 30.03.2025

ETH-Bibliothek Zürich, E-Periodica, <https://www.e-periodica.ch>

Experimental Investigation of Traffic Load on Highway Bridges
Vérifications expérimentales de la charge mobile sur les ponts-routes
Experimentelle Untersuchungen der Verkehrslast auf Strassenbrücken

Andrej SOKOLÍK
Prof. Dr.
Univ. of Transport and Commun.
Zilina, Slovakia



Andrej Sokolík, born 1944, got his civil engineering and Ph.D. degree at the UTC of Zilina, Slovakia. For three years he was involved in the design and testing of railway and highway bridges. He spent two years in Jordan at the Ministry of Public Works. He is currently the head of Department of Civil Structures and Bridges.

SUMMARY

The dynamic response of two highway bridges subject to normal road traffic load has been investigated in order to obtain a file of statistical data as well as to identify their dynamic characteristics and to compare the behaviour of both bridges. A measuring and computing system was used for recording analog signals of the bridge deflection together with their subsequent digitization with statistical processing of the measured data by computer. This resulted in more representative data of dynamic and traffic parameters of bridges.

RÉSUMÉ

Le comportement sous effets dynamiques a été mesuré sur deux ponts-routes sous charges mobile normale, afin d'obtenir des données statistiques relatives aux charges, des renseignements sur le comportement aux vibrations propres et de pouvoir comparer ainsi les deux ouvrages. Pour ce faire, il a été fait appel à un système de mesure avec enregistrement analogique automatique des flèches; ces dernières, après avoir subi une conversion numérique, ont été soumises à un dépouillement statistique des données représentatives des paramètres et des sollicitations dynamiques des ponts.

ZUSAMMENFASSUNG

Das dynamische Verhalten zweier Autobahnbrücken unter normaler Verkehrsbelastung wurde gemessen, um statistische Belastungsdaten, aber auch Aufschluss über das Eigenschwingverhalten und einen Vergleich beider Brücken zu erhalten. Dabei wurde ein Messsystem mit automatischer Analogaufzeichnung der Durchbiegungen verwendet, die digitalisiert und einer statistischen Auswertung unterzogen wurden. Das Ergebnis sind repräsentative Daten der dynamischen Parameter und Beanspruchung der Brücken.



1. INTRODUCTION

From the point of view of service reliability of a bridge construction as well as an increase in traffic intensity on highways together with an effort to apply the knowledge of theory of reliability to the design of this type of structures we need to clarify many partial problems connected with the solution of the system *bridge-loading-environment*. At present the main task is to obtain a true picture of the load magnitude and its effects on the structure. For this reason it is clear that bridges which are subjected to considerable dead and moving load as well as to a secondary load deserve a maximum attention.

2. THE MEASURING AND COMPUTING SYSTEMS

A measuring system (Fig. 1) has been developed to provide measuring time variations of the bridge deflection, encoding the passing trucks into 8 + 2 categories (Table 1) and sensing their axles together with the directions of the drive. Both, analog signals (deflections) and discrete data (traffic parameters) are stored by an instrumentation tape recorder. The deflection sensing device consisting of a wire stretched by a spring and an inductive displacement transducer or a stretched resistance wire between the measurement point and the terrain are used to measure the bridge deflections [1].

A minicomputer system (Fig. 2) with a real-time operating software is exploited to digitize and preprocess the recorded deflections together with the discrete data on the vehicles. The results are digital records containing just a relevant part of the digitized deflection signal and a block of the data on the trucks which have evoked previous responses.

A Fortran IV programme computes dynamic parameters (Fig. 3) as they are defined by the Czechoslovak Standard 73 6209 [2]. The digital filtering is used to obtain a mean deflection curve and to select a pure dynamic portion of the signal. The computation results in the dynamic parameters for each relevant response of the bridge to the passing trucks together with the discrete data on the trucks.

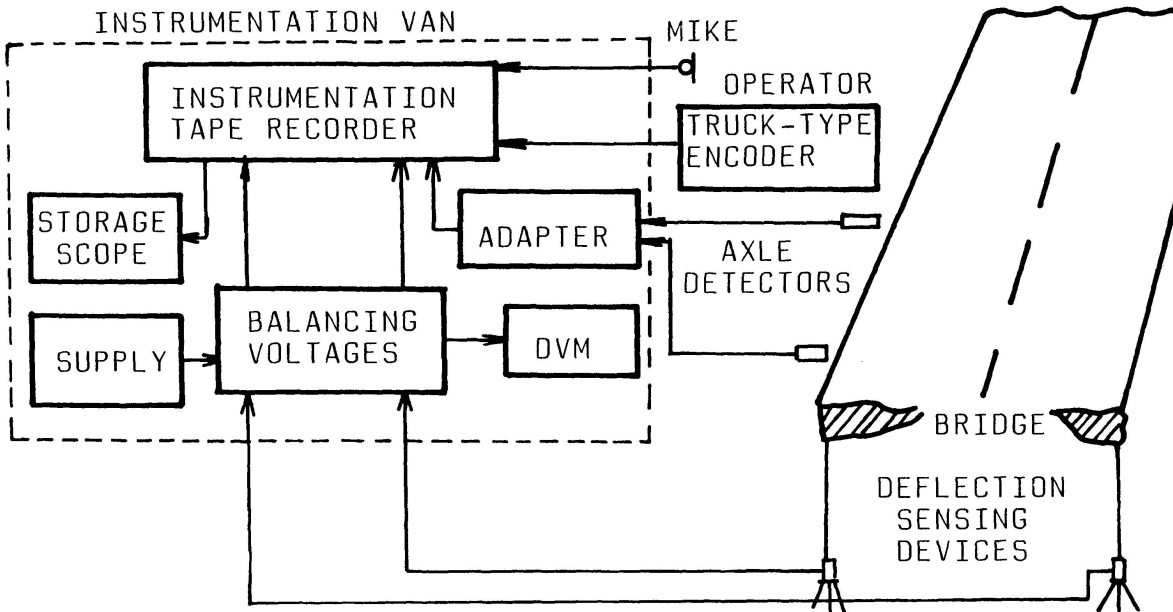

Fig. 1 The measuring system for monitoring bridge deflections and some traffic parameters

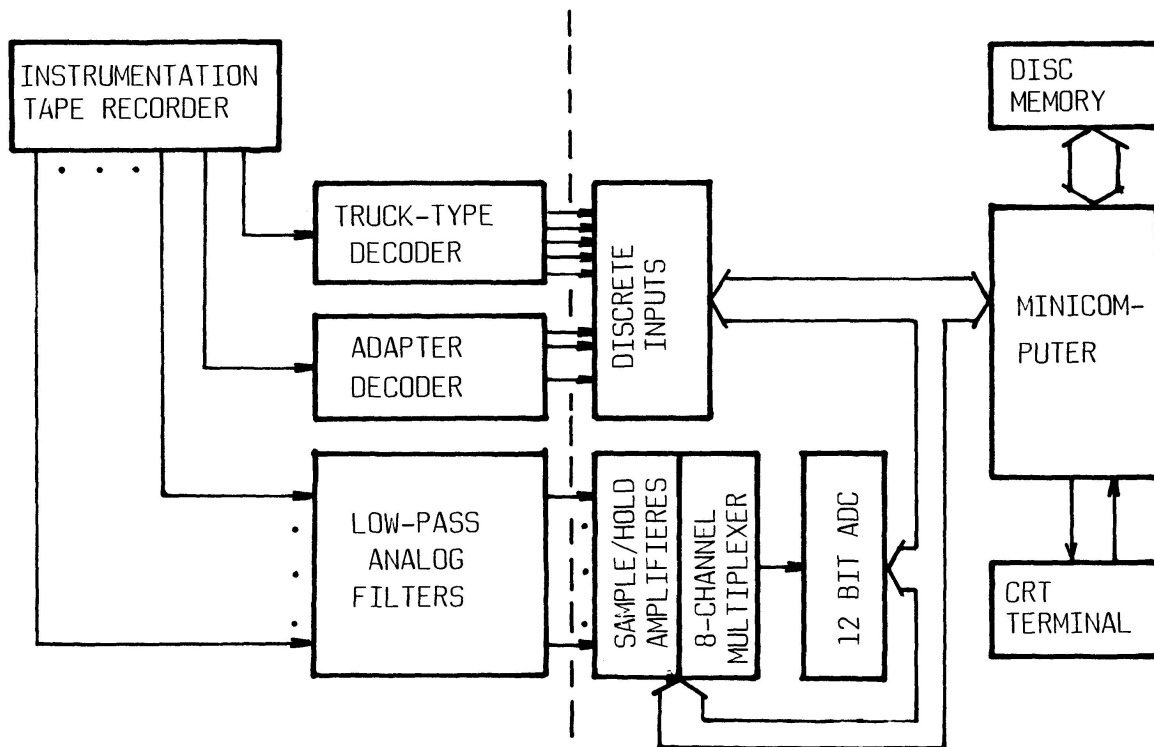

Fig. 2 The computing system for preprocessing the recorded analog and discrete signals

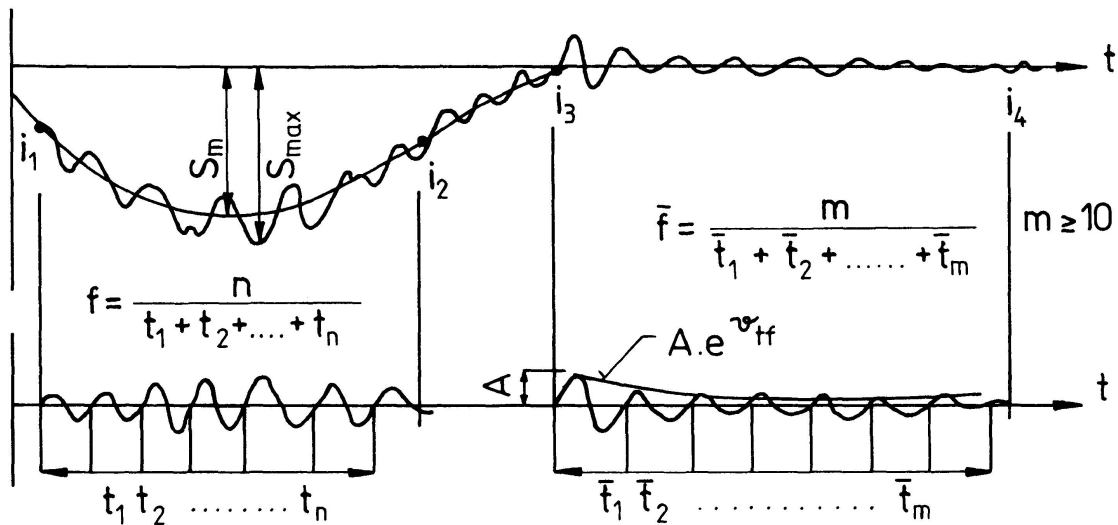

Fig. 3 Illustration of computing the natural frequencies f and \bar{f} , the damping ψ and the dynamic coefficient S_{\max}/S_m

A nonrecursive low-pass filter produces a mean deflection curve. The first and the second differences of this curve are continually evaluated as to locate the inflection points i_1, i_2 and the minimum S_m . At the interval $\langle i_1, i_2 \rangle$ vibrations of the loaded bridge are investigated and the S_{\max} is located. To distinguish the natural frequency f from higher frequencies induced by dynamic wheel loads of the vehicles a nonrecursive band-pass filter is applied on the signal at the interval. The same filter is used to find out the natural frequency \bar{f} of free decayed vibrations and the logarithmic decrement of damping ψ . The programme processes also the encoded data about the vehicles, which exited the previously evaluated records of the bridge deflections. Speeds, axle bases and the categories are calculated and output as the traffic data.

3. THE LONG TERM OBSERVATION OF INFLUENCE OF THE TRAFFIC LOAD ON THE BRIDGE

The long term observation has been carried out on two one span bridges on the first class highway. Both bridges are of the same construction system. The structure is made of standard post-tensioned concrete (50 MPa) I-girders (Fig. 4). The former is of 26 m span and its construction height is 1.25 m. The latter is of 21.26 m span and is 1.1 m high. The substructures are created by massive abutment with the parallel wings. The expansion joints are placed above one abutment only.

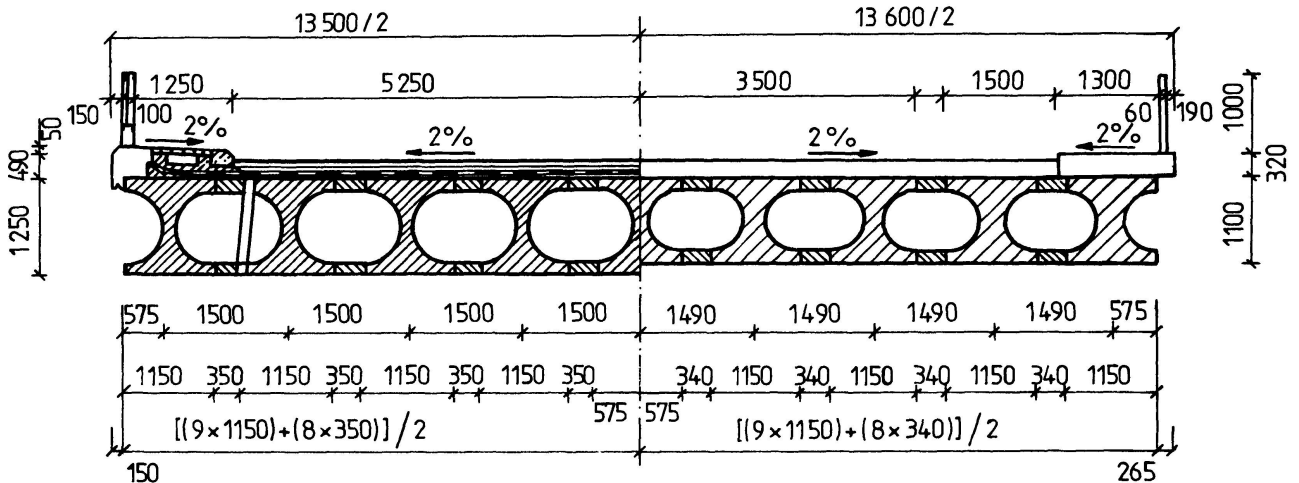

Fig. 4 Crossection of the bridge near H. Hričov and K. Lhota



The position of the bridges on the highway network is characterized by the transport intensity. We have recorded about 2.000 passing trucks on the first bridge and about 2.400 on the second one during the same period. The trucks have been encoded into 8 categories according to the number of axles, type of a truck, axle distances and bearing capacity, plus two extraordinary categories (Table 1). The operator observes the traffic and operates the recorder by the truck-type encoder. He selects the pushbutton corresponding with the category and the drive direction of the passing truck or with an extraordinary situation on the bridge.

3.1 Histograms and their statistical characteristics

Having processed the whole group of the digitized deflection signals the obtained results were processed by the *Fortran programme* which compiled the measured values into the histograms of the deflection distribution for each category and drive direction of the trucks as well as for the whole group.

Then the statistical data of the histograms were computed and the approximation by the following theoretical probability distribution was tried: *Weibull's, Gumbel's, Raleigh's, Exponential, Normal and Logarithmic-normal, Gama and Chi-model*. We have carried out the statistical testing based on the assumption that at least one of the theoretical probability distribution is realistic for distribution obtained from the measurement and that at least one of the introduced theoretical distribution would correspond to this

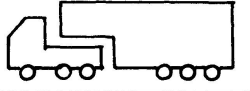
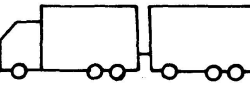
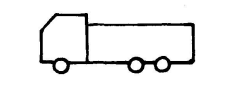
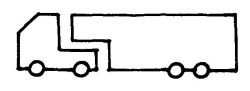

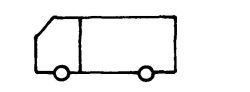
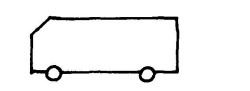
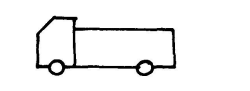
	SCHEME	VEHICLE TYPES	1st BRIDGE		2nd BRIDGE	
			THEORETICAL MODEL			
				No OF TRUCKS		
1		VOLVO T 813 T 138 } +SEMI-TRAIL	WEIBULL 'S	57	67	NORMAL
2		VOLVO T 813 T 138 } TRAIL	GUMBEL 'S	57	76	WEIBULL 'S
3		T 111 T 813 T 138 T 148	GUMBEL 'S	165	205	LOG-NORMAL
4		Š 706 } +SEMI-TRAIL Š 100 }	GUMBEL 'S	178	210	WEIBULL 'S
5		Š 706 } TRAILER Š 100 }	GUMBEL 'S	195	265	NORMAL
6		Š 706 Š 100	GUMBEL 'S	379	485	LOG-NORMAL
7		BUSES Š 706-RTO SL 11, SC 734 IKARUS	GUMBEL 'S	153	217	LOG-NORMAL
8		V 35-ROMAN S5T, AVIA ROBUR, IFA	WEIBULL 'S	371	410	FRECHET 'S
9	UNIVERSAL GROUP	ALL VEHICLES DON'T INCLUDED IN GROUPS 1-8	GUMBEL 'S	94	124	NORMAL
0	UNIQUE GROUP	PASSING AND MEETINGS 2 VEHICLES	GUMBEL 'S	344	350	WEIBULL 'S
	ALL PASSING TRUCKS		GUMBEL 'S	1989	2409	WEIBULL 'S

Tab. 1 The schemes of the 8 most occurring trucks plus 2 extraordinary categories and the corresponding optimal theoretical probability distribution models of the deflections for each category as well as for the whole group of the passing trucks

distribution. The parameters of the competent theoretical distribution for each group of deflection were calculated together with the significance test of each distribution [4].

Analysing the results achieved on the first bridge we have found out that the *Gumbel's* model, at the 5% significance level, is the most suitable in 72% and the one of *Weibull's* in 28% of all the histograms in which the measured deflections were divided according to the category of trucks as well as according to the both directions of drive. On the second bridge we have found out that the *Weibull's* model can be taken as an optimal theoretical one in 30% of all the histograms. For 30% of them the *Logarithmic-normal* model is the most suitable one as well as the normal one for other 30% of all the histograms. For the rest (10%) the *Frechet's* model is optimal.

3.2 Dynamic characteristics of both bridges

In Table 2 there are *natural frequencies* of the loaded and the unloaded bridges. It can be seen that the mean natural frequency of the second loaded bridge is higher approximately by 1.0 Hz than the frequency of the first one. This difference confirms the reality that with a growth of rigidity of construction its frequency grows up.

FREQUENCY (Hz)	1 st BRIDGE			2 nd BRIDGE		
	MIN	MEAN	MAX	MIN	MEAN	MAX
LOADED BRIDGE	1,000	4,700	12,500	3,900	5,667	8,820
UNLOADED BRIDGE	-	-	-	5,560	5,759	8,200

Tab. 2 The frequencies of vibrations of the bridges

Table 3 shows the values of the *logarithmic decrement of damping* (ψ), the *dynamic coefficient* (δ) as well as the *dynamic increment* which have been measured according to the Czechoslovak Standard [2]. Here we would like to mention the fact that the dynamic coefficients have been greater by 3 to 10% in one direction of drive than in the opposite one. This difference of the dynamic influences is due to



the expansion joint which lies on the abutments of both bridges in one direction only.

BRIDGE	LOGARITHMIC DECREMENT OF DAMPING (ψ)			DYNAMIC COEFFICIENT (δ)			DYNAMIC INCREMENT		
	MIN	MEAN	MAX	MIN	MEAN	MAX	MIN	MEAN	MAX
FIRST	-	-	-	1,05	1,165	2,10	0,015	0,085	0,195
SECOND	-0,134	0,170	0,500	1,00	1,118	1,875	0,010	0,072	0,180

Tab. 3 Some dynamic characteristics of second bridge

The analysis of the correlation between the maximum deflections and the dynamic coefficients respectively, the dynamic increment has shown that in all cases on both bridges the negative respectively positive coefficient of correlation (for linear as well for logarithmic and exponential dependence) is very high and its values are very close to 1.0. The results have confirmed that with an increasing traffic load the dynamic coefficient decreases but the dynamic increment increases.

4. CONCLUSION

In conclusion we can say that for further theoretical investigation of durability as well as a reliability analysis of a bridge construction the *Weibull's* or *the Gumbel's* theoretical model of probability distribution of the deflection could be considered as a response of the bridges to the vehicular loads. Further we can say that we have obtained average values of some dynamic characteristics of that type of the bridge from ample statistical data.

REFERENCES

- [1] KYŠKA R. - POLLAK T.: Measurement of dynamic properties of bridges IMEKO X. Preprint, Vol. 3 Prague 1985 pp. 155-162
- [2] ČSN 73 6209 "Zatěžovací skoušky mostů". Praha 1980.
- [3] SOKOLÍK A. at al." Dynamické charakteristiky mostov z betónu. Závěrečná správa VÚ P12-526/267/E04. VŠDS Žilina 1983.
- [4] CLARKE G.M. - COOKE D.: A Basic Course in Statistic. ELBS LONDON 1983.