

Zeitschrift: IABSE reports = Rapports AIPC = IVBH Berichte
Band: 67 (1993)

Artikel: Redundancy and the reserve and residual strength of frames
Autor: Billington, Colin J. / Bolt, Helen M. / Ward, J. Keith
DOI: <https://doi.org/10.5169/seals-51387>

Nutzungsbedingungen

Die ETH-Bibliothek ist die Anbieterin der digitalisierten Zeitschriften. Sie besitzt keine Urheberrechte an den Zeitschriften und ist nicht verantwortlich für deren Inhalte. Die Rechte liegen in der Regel bei den Herausgebern beziehungsweise den externen Rechteinhabern. [Siehe Rechtliche Hinweise.](#)

Conditions d'utilisation

L'ETH Library est le fournisseur des revues numérisées. Elle ne détient aucun droit d'auteur sur les revues et n'est pas responsable de leur contenu. En règle générale, les droits sont détenus par les éditeurs ou les détenteurs de droits externes. [Voir Informations légales.](#)

Terms of use

The ETH Library is the provider of the digitised journals. It does not own any copyrights to the journals and is not responsible for their content. The rights usually lie with the publishers or the external rights holders. [See Legal notice.](#)

Download PDF: 22.11.2024

ETH-Bibliothek Zürich, E-Periodica, <https://www.e-periodica.ch>

Redundancy and the Reserve and Residual Strength of Frames
Redondance, réserve de résistance et capacité restante de cadres
Redundanz, Reserve- und Restfestigkeit von Rahmen

Colin J. BILLINGTON
Director
Billington Osborne-Moss
Maidenhead, UK

Helen M. BOLT
Supervising Engineer
Billington Osborne-Moss
Maidenhead, UK

J. Keith WARD
Associate
Billington Osborne-Moss
Maidenhead, UK

Director and co-founder of BO-MEL, Colin Billington has been responsible at senior management levels for establishing and developing R&D organisations including the Steel Construction Institute. His contributions to structural engineering technology and practice are widely recognised, with more than 80 publications to his credit.

Since her academic training at Imperial College, Helen Bolt has been involved with development of the reserve and residual strength technology for offshore jacket structures. She was the engineer on site for the experimental work described in this paper. As Supervising Engineer she now takes overall responsibility for R&D activity.

Keith Ward's expertise is in the analysis of complex problems in offshore engineering. He led the development of the nonlinear programme described in this paper, which is now used to determine the reserve and residual strength of jacket structures. As Associate he leads the company's analysis and software development activities.

SUMMARY

For undamaged structures the conservatism in conventional design practices ensures that a substantial reserve strength exists beyond the design event. Similarly, the redundancy of the structure gives a residual strength enabling it to sustain load even in a damaged condition. Reserve and residual strength, redundancy and collapse mechanisms are important considerations in the design and reassessment of offshore jacket structures. Large scale collapse tests of frames were undertaken and these are described in the paper with a discussion of the findings and analysis predictions.

RÉSUMÉ

Pour les structures intactes, la pratique prudente des méthodes d'étude traditionnelles assure la présence d'une réserve de résistance au-delà de la résistance nominale. De même, la redondance de la structure offre une capacité restante qui lui permet de résister à une charge même en cas de dommages. La réserve de résistance et capacité restante, la redondance et les mécanismes de rupture sont des considérations importantes dans l'étude et la ré-évaluation des structures des chemises des plate-formes en mer. Des essais de rupture de cadres ont été effectués sur une grande échelle; ils sont décrits dans l'exposé, avec une discussion des conclusions et des recommandations.

ZUSAMMENFASSUNG

Bei unbeschädigten Bauwerken wird durch den Konservatismus der konventionalen Entwurfspraktiken eine bedeutende Reservefestigkeit über den Auslegungsfall hinaus gewährleistet. Auf ähnliche Weise wird durch die Redundanz der Konstruktion eine Restfestigkeit erreicht, wodurch gewährleistet wird, dass sie auch in einem beschädigten Zustand die Last tragen kann. Reserve- und Restfestigkeit, Redundanz und Einsturz-mechanismen sind für die Entwurfsgestaltung und Neubewertung von Offshoreplattformen von grosser Bedeutung. An Rahmen wurden Kollaps-grossversuche ausgeführt, die in dem Schriftstück mit einer Diskussion der Ergebnisse und Analyse-voraussagen beschrieben werden.



1. INTRODUCTION

Traditionally offshore steel jackets are designed on a component by component basis. Each member and joint is checked against the strengths given in design codes, which themselves have been established from the database of isolated joint and tubular beam-column test results.

In practice a structure's ability to resist loads in excess of the design load (the 'reserve strength') depends not only on the conservatism in the design of individual members and joints, but also on the performance of these components within the frame. Thus the ratios of the collapse load to the design load derived from the critical component, may differ even between structures which have been designed to the same code. Influences of the overall system response on the ultimate capacity of frames, are not generally accounted for in the design of offshore jacket structures since no specific guidance is given within the codes. However, these are being recognised increasingly as important factors in the selection of new platform configurations and in the reassessment of existing installations.

Beyond the ultimate state, be it brought about by accidental damage or overloading, there is an additional requirement for the structure to remain intact, redistributing the loads safely without catastrophic collapse. The ability of a structure to sustain damage in this way, its 'residual strength', is quantified by the ratio of the collapse loads for the damaged and intact structures and depends largely on the structural redundancy within the system. Again, in traditional engineering practice, residual capacity is not considered explicitly in design. However, experiences offshore of changing operational requirements and instances of damage, have emphasised the importance of building redundancy into jacket structures.

If reserve and residual strengths either cannot be quantified justifiably or are considered to be inadequate, the consequences can be costly in terms of repairs or strengthening measures which may in fact be unnecessary or may be carried out at greater risk in inclement weather conditions. With a better understanding of the issues and more prudent designs in the future, it may be that fewer offshore modifications will be required. More detailed description of the sources of reserve and residual strength and early experimental investigations are given in the companion paper presented by the authors at the Inspection, Repair and Maintenance Conference in Aberdeen in 1988 [1].

The ability to understand and quantify the influences on the reserve and residual strength of frames, their redundancy and collapse mechanisms is now an increasing demand of the offshore industry. This is required both for the reassessment of existing structures and for the selection of configurations for new structures. In recognition of both the technical and economic benefits to be gained for the offshore industry, the Joint Industry Tubular Frames Project was established in 1987 to address some of the many questions then arising and to develop a calibrated technique for reserve and residual strength calculations. Sponsored by nine offshore Operators and the UK Department of Energy, the Project marks a significant advance in the application of the reserve and residual strength technology to offshore jacket structures.

Through experiments the project has given unparalleled examples of the ultimate response of frames related to both member and joint failures and has illustrated the important role of redundancy. The frames were the largest ever to have been pushed to collapse in a controlled manner. Coupled with the development of a new nonlinear program, SAFJAC, the Project gave the Participating Organisations a significant advancement in their ability to understand and predict the behaviour of both planned and existing installations.

2. THE JOINT INDUSTRY TUBULAR FRAMES PROJECT

Although early studies had emphasised the role of reserve and residual strength in determining the ultimate capacity of frames, they did not supply sufficient information or a calibrated numerical tool to assess offshore jacket structures of current concern in the North Sea. The Tubular Frames Project was therefore established [2]. The first phase of this joint industry project commenced in November 1987 and was completed in January 1990. The confidentiality period for the Phase I work expires in 1993 and the objectives, scope and findings from the work are described in these sections. In the following section Phase II, which commenced in June 1990, is introduced.

2.1 Objectives of the Frames Project

The overall objectives of the project may be summarised as follows:

- to establish the effects of non-linear joint/member behaviour on frame behaviour and collapse mechanisms.
- to quantify the reserve and residual strength of frames (global safety margins) and to investigate redundancy and load shedding characteristics.
- to investigate the collapse performance of members and joints within frames and to develop procedures for the exploitation of available component data.
- to investigate residual strength and load shedding behaviour of a frame which includes a 'cracked' joint (Phase I).
- to develop a non-linear numerical procedure for the collapse analysis of frames.

2.2 Experimental Scope - Phase I

Four tubular frame tests were conducted to investigate the influence of different modes of failure on reserve and residual strength in Phase I. The general arrangement of the frames and the test set-up are shown in Figure 1.

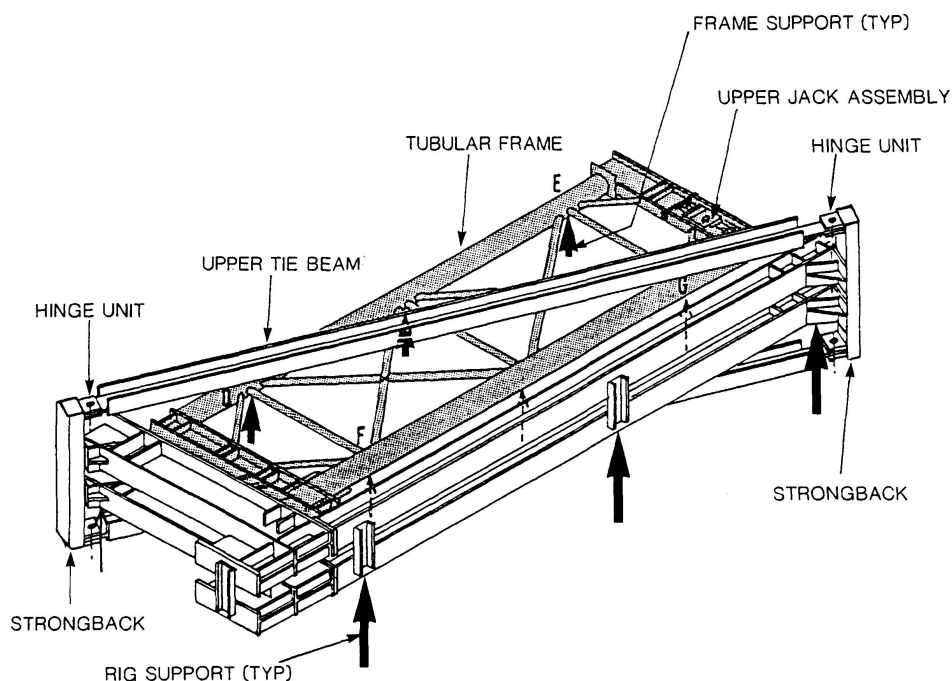

Fig. 1 Frame test general arrangement



The frames constitute the largest specimens ever to be tested to collapse in a controlled manner. General features of the test frames are summarised below:

- the four frames resembled prototypes as closely as possible, representing a scale factor of greater than one-third with respect to typical southern North Sea jacket structures.
- size effects were avoided by adopting minimum tubular diameters and thicknesses of 168mm and 4.5mm, respectively.
- non-dimensional parameters reflected current offshore practice.
- standard offshore fabrication procedures were adopted.
- the influence of boundary conditions was minimised by pinning the frame legs at the base.

The basic configuration of the two-bay, X-braced test frames, 15m high and 6m wide, is shown in Figure 2.

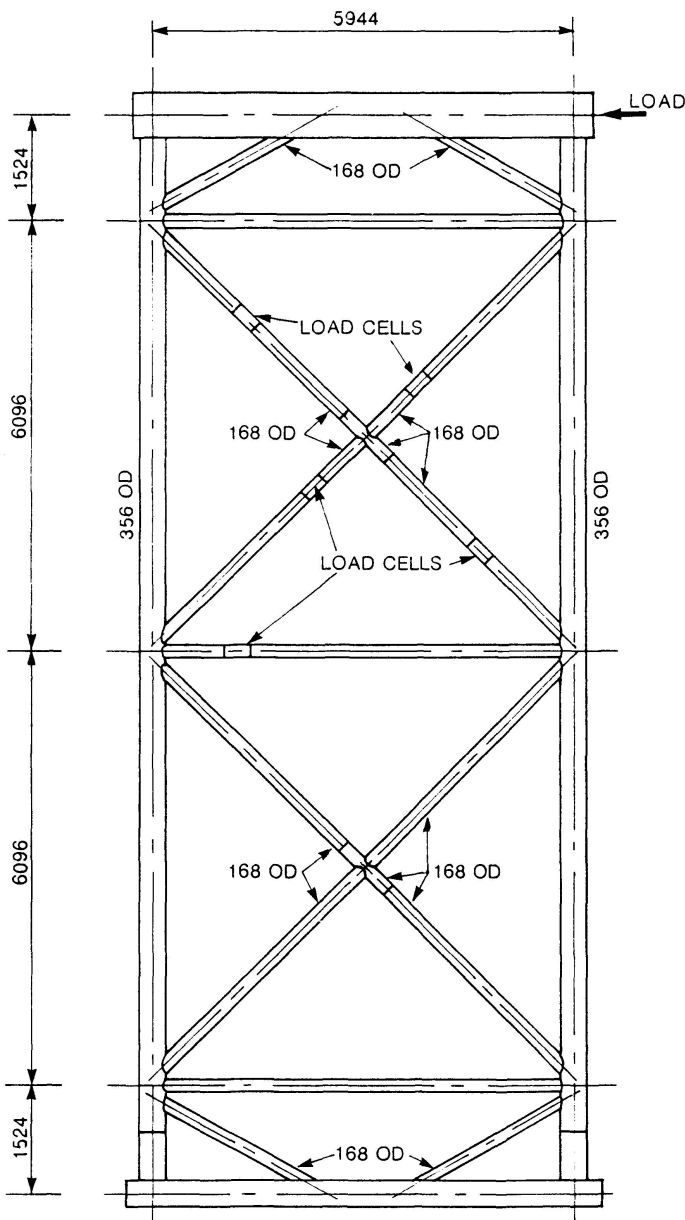

Two-bay X-braced frames were selected for the following reasons:-

- X-braced configurations are a popular choice for offshore substructures.
- X-braced frame behaviour provided a stringent test for calibration of the computer program.
- Early generation X-braced jackets usually did not have joint cans, and this situation of practical concern was replicated by one test enabling joint failure and load shedding characteristics within the frame to be studied.
- No large scale X-braced frames of geometries typical of offshore construction had previously been tested.
- Two-bay frame tests were selected to enable load shedding between bay panels, important in the understanding of frame behaviour, and redundancy to be studied. X-braced panels exhibit a significant residual strength after failure of one member, and the presence of a second bay enables this form of behaviour to be fully and realistically captured without interference from end restraints.

Fig.2 X-braced test frame configuration

The following features of the four frames distinguished their responses:

- Frames I and III were dominated by compression brace instabilities. The frames were nominally identical except that the horizontal brace between the two bays was omitted in Frame III, enabling its contribution to capacity to be assessed.
- Frames I and II were nominally identical, with the exception that the chord can for the top bay DT joint in Frame II was omitted such that joint collapse precipitated failure.
- Frame IV failure was initiated by propagation of a fatigue crack introduced at the critical DT joint of a specimen nominally identical to Frame II.

The frames were fabricated in Aberdeen and tested on site by the authors in a self-reacting rig, seen in the diagram in Figure 1 and the photograph, Figure 3.

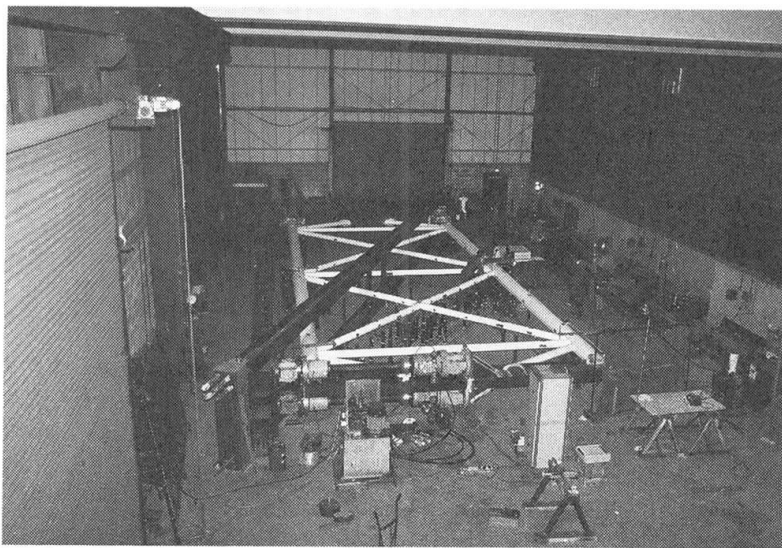

Fig. 3 View of Phase I frame test

The frames were subject to a thorough dimensional and straightness survey before and after testing and were monitored during loading by extensive instrumentation.

Lateral load was applied to the frames under displacement control; in undertaking the test programme, it was recognised that capturing the post ultimate behaviour was essential for the future calibration of the developed software. Previous experimental programmes had addressed the ultimate limit state of a component without due regard to the post-ultimate ductility. In order to ensure that the reserve and residual strength characteristics were fully assessed, all tests in the programme were carried out using equipment and test arrangements capable of handling large displacements in a controlled manner. In addition to the frame tests, tensile coupons, stub columns and tubular joint components were tested. Before discussing the findings from the tests, the scope of the parallel software development activities is reviewed.

2.3 Analytical Scope - Phase I

The purpose of the analytical work was to develop a non-linear numerical program to estimate the reserve and residual strength of tubular frames. The program developed has been called SAFJAC (Structural Analysis of Frames and Jackets) and has the capability to predict large displacement behaviour of plane and space frames including the effects of material plasticity. Development focused on simple structural idealisations and efficient non-linear solutions.



The analytical workscope began with a review of published data and information to define load-deflection characteristics of members and joints against which the existing finite element programs were calibrated. They were then used to develop new parametric relationships for the specification of joint stiffness curves in terms of both peak loads and associated displacements.

The numerical activities within the Project then concentrated on the development of a software package with new finite elements encompassing automatic sub-division to accommodate plasticity and with a non-linear representation of joints [3]. This route was chosen to complement commonly available numerical methods which are finite element based, some of which require several beam elements to monitor the P-delta effects associated with large deflections. Further, the new software contrasts with the phenomenological models available which, whilst computationally efficient, may be considered to require greater expertise from the analyst.

An elastic quartic element was developed to model each member in a frame. This was programmed to sub-divide automatically as plasticity occurred, introducing at its ends either a plastic hinge or a new cubic element devised to monitor the spread of plasticity. The facility to model non-linear joint characteristics was introduced in the program with a piece-wise linear representation. The new elements were calibrated in isolation and against frame test results from both the open literature and the experimental programme. In Phase II the elements and automatic subdivision facilities were extended to give full two and three-dimensional capability.

2.4 Findings - Phase I

The findings from the experimental programme have important ramifications for the repair and maintenance of existing installations as well as for the design of new structures. In addition to the wealth of information gathered from the associated tests, the frames themselves demonstrated substantial reserves of strength.

The findings can be summarised as follows:

- Significantly larger than expected reserve and residual strengths were recorded compared with individual component responses.
- Frames dominated by joint failure exhibited greater reserve strengths than those in which member failure occurred first.
- The relationship obtained in respect of interaction between joint loading-unloading characteristics and overall frame system response was unexpected for both intact and fatigue cracked critical joints.

For the first time, experimental and numerical evidence had been generated which seemed to indicate unusual and unexpected frame action effects for tubular joints. These findings potentially impact on all aspects of tubular joint design practices (both static and fatigue), from isolated joint testing procedures, (which may not be adequately capturing frame effects [4]), to joint data interpretation, failure definition, capacity and joint detailing practices. In recognition of these unexpected and significant findings, a Phase II project was proposed as an extension to Phase I, to address these issues within the context of reserve/residual strength calculations. This is described in the next section.

The role of redundancy in the X bracing was demonstrated by the ultimate frame response. As the compression joint in the top bay began to yield, so the compression load path softened. A greater proportion of the applied load was therefore distributed via the alternative tension diagonal enabling the structure as a whole to sustain increasing loads. This response may be contrasted with a K braced structure where the lack of redundancy through the joint ensures that failure of one component constitutes failure of a panel.



With regard to member failures, the frame tests enabled reserve and residual capacities to be quantified. Furthermore, comparison of results from tests I and III supplied much needed information about the role of horizontal bracing in the ultimate response of X-braced jacket structures. These two frames were tested specifically to illustrate the role of redundancy on the system reliability. Frames I and III were nominally identical but for the absence of the midheight horizontal (see Figure 2) in the latter case. In elastic design this member carries no load and with trends towards lighter, liftable jackets designers are being encouraged to omit these redundant members. The tests showed that although initial failure in both frames was by buckling of the compression brace in the upper bay, the post-peak response was severely compromised in the absence of the horizontal.

In this second case a rapid succession of failures was initiated with a residual frame capacity below the original design load. As the compression brace buckled, so a greater proportion of load was transmitted via the tension diagonal. At the midheight level the only path for the load was the lower bay compression diagonal which soon buckled. The redundancy afforded by the horizontal in the first instance however, had ensured a more even redistribution of load without initiating further component failures. At the midheight level the load from the top bay tension diagonal divided between the horizontal and lower bay compression diagonal.

The midheight horizontal constituted just 2.5% of the structural weight yet the alternative load paths that the redundancy afforded assured a factor of 1.3 on residual capacity. In terms of safety, the redundancy had a significant contribution.

Excellent agreement with the frame test results was achieved by SAFJAC analyses and this has ensured that the program may be used with confidence for the analysis of offshore jacket structures. Indeed, Participating Organisations are already performing 2-D and 3-D pushover analyses using SAFJAC as part of their reassessment of existing installations for re-certification.

In addition to conclusions regarding reassessment procedures, Phase I led to recommendations for the use of the reserve strength technology in the evaluation of new designs. The aim is to ensure that minimum operator-specified reserve strength factors are achieved, thereby enabling structural redundancy to be fully and safely exploited even though this requirement is not yet specifically stipulated in design codes. This approach should lead to efficient and versatile structures for which the need for in-service modifications and/or repairs is much reduced.

Other recommendations focused on the need for future work to examine the issues surrounding joint failure and frame mounted joint capacities, and for K configurations to be addressed. It was also acknowledged that SAFJAC should be developed and extended to enhance its capabilities. The importance of the findings from Phase I of the Frames Project gave impetus to the commencement of Phase II along the lines noted above.

3. FRAMES PROJECT PHASE II

3.1 Overview

A Phase II of the Frames Project was developed by the Participants and BOMEL, with the following objectives:

- To establish further the performance of joints in X-braced and K-braced frames and to investigate the effects of joint failures on the performance of these frames up to and beyond the ultimate limit state.
- To establish levels of reserve strength in X-braced and K-braced frames.



- To examine the effect of load reversals on the ultimate response characteristics of joints.
- To undertake lack-of-fit stress measurements.
- To enhance, calibrate and apply the non-linear numerical procedure SAFJAC for the collapse analysis of frames.

Work commenced in June 1990 and was recently completed. Of the frame tests, two were double-bay X-braced as in Phase I, (Figure 2), and four were of single bay K-braced configurations as shown in Figure 4.

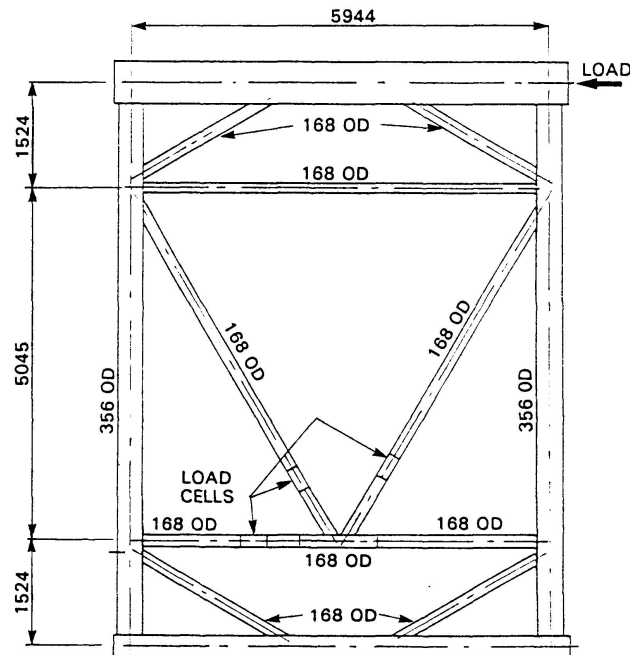

Fig. 4 K-braced test frame configuration

3.2 Experimental Programme - Phase II

Taking account of the findings from Phase I and recent numerical investigations into the ultimate response of frame mounted joints, six frames were tested within Phase II as follows:

- Frame V is nominally identical to the two-bay X-braced Frame II from Phase I and was tested up to the point of joint failure to verify the ultimate capacity of the joint in the frame.
- Frame VI reuses the Frame V structure but with a replacement joint, carrying compression in the through member rather than the braces. The test continued through joint failure up to the maximum displacement available in the rig, thereby investigating post-peak response.
- Frame VII, the first K-braced frame, is detailed for first failure of the simple gap K-joint. Frames VIII and X are variations of Frame VII with different diameter and gap ratios, β and ζ . For all the K-braced frames the tests continued such that both reserve and residual characteristics of the joint and frame were revealed.
- Frame IX, complements the Frame VII test being nominally identical but for the specification of a significant overlap at the K-joint.
- Companion tests of nominally identical isolated joints are an important part of the Phase II programme enabling the role of constraints within the frame to be quantified [4].



These results, coupled with detailed support monitoring and residual 'locked-in' stress measurements, have significantly advanced the understanding of the ultimate response of frames and joints.

4. CONCLUSIONS

From the description of the Joint Industry Tubular Frames Project presented in this paper, it can be seen that the tests are providing new and important information about the reserve and residual strength of structures. A number of significant and unexpected findings have been noted. For the first time, frame tests have been carried out where joint failure precedes member failure, a scenario in line with current design practices which dictate an equal likelihood of joint failure as of member failure. Frame behaviour has been observed which impacts on all aspects of tubular joint and frame design practices. In recognition of these unexpected and unanswered findings, a second phase of work was recently undertaken to develop the technology further. The parallel development of a calibrated numerical tool, SAFJAC, ensures that the findings can be directly applied to both planned and existing offshore jacket structures.

An increasing awareness of the need to quantify reserve and residual strength is being raised for a variety of reasons:

- Re-assessment of existing installation is being required more often due to:-
 - more onerous loading, as environmental conditions are reviewed,
 - additional topside loading to extend facilities or meet new safety criteria,
 - requirements to extend the platform life beyond its design value to exploit remaining hydrocarbon reserves,
 - deterioration of capacity through damage or corrosion.

The intention of re-analysis is to assess the fitness for purpose of the structure under the modified load/resistance regime and to ascertain whether strengthening measures are essential for safe operation. In many instances, if the combined reserve strength resources could be demonstrated, the need for costly strengthening measure may be removed.

- Cost is also driving the trend towards lightweight structures with few primary members and a commensurate reduction in reserve and residual strength. The implications for such structures subjected to design storm loading or accidental loading can only realistically be assessed through pushover analyses.
- The advent of limit state codes requires a thorough understanding of the ultimate strength of structures in both the intact and damaged conditions. Hard evidence is being generated by the frames tests.

The data and information resulting from the Frames Project and the availability of a calibrated and substantiated non-linear numerical procedure will allow the safe and economic application of steel jacket structures. It will enable the proper exploitation of redundancy inherent in jacket structures whilst maintaining desired safety levels. In addition, it will provide an important tool in the reassessment of intact or damaged existing structures, leading to the identification of global safety levels and the development of inspection, maintenance and repair (or strengthening) procedures in a more rational, cost-effective and complete manner than has been possible in the past.

Analytical phases of the work are continuing and a 3D structural collapse test is planned to investigate load redistribution between structural planes and the role of redundancy.



5. ACKNOWLEDGEMENT

Phase I of the project was carried out by the authors under the auspices of the Steel Construction Institute. The software (SAFJAC), which was developed by personnel from Imperial College working under the direction of the authors, is confidential to the Participants.

6. REFERENCES

1. LALANI, M AND BOLT, HM, The role of reserve and residual strength in determining the repair and maintenance needs of steel jackets. IRM '88 Conference, Aberdeen, 1988.
2. BILLINGTON OSBORNE-MOSS ENGINEERING LIMITED, Joint industry funded research programme. Analytical and experimental investigation of the behaviour of tubular frames. Phase II. Invitation to participate. Document N^o BOMEL 138/89, September 1989 and Document N^o BOMEL 166/90, January 1990.
3. LALANI, M AND SHUTTLEWORTH, EP, The ultimate limit state of offshore platforms using reserve and residual strength principles. Paper OTC 6309, Offshore Technology Conference, Texas 1990.
4. CONNELLY, LM AND ZETTLEMOYER, N, Frame behaviour effects on tubular joint capacity. IIW Conference, Finland 1989.