

**Zeitschrift:** IABSE reports = Rapports AIPC = IVBH Berichte

**Band:** 67 (1993)

**Artikel:** Remaining carrying capacity of temporary steel bridges

**Autor:** Juhás, Pavol / Juhásová, Emilia

**DOI:** <https://doi.org/10.5169/seals-51391>

### **Nutzungsbedingungen**

Die ETH-Bibliothek ist die Anbieterin der digitalisierten Zeitschriften. Sie besitzt keine Urheberrechte an den Zeitschriften und ist nicht verantwortlich für deren Inhalte. Die Rechte liegen in der Regel bei den Herausgebern beziehungsweise den externen Rechteinhabern. [Siehe Rechtliche Hinweise.](#)

### **Conditions d'utilisation**

L'ETH Library est le fournisseur des revues numérisées. Elle ne détient aucun droit d'auteur sur les revues et n'est pas responsable de leur contenu. En règle générale, les droits sont détenus par les éditeurs ou les détenteurs de droits externes. [Voir Informations légales.](#)

### **Terms of use**

The ETH Library is the provider of the digitised journals. It does not own any copyrights to the journals and is not responsible for their content. The rights usually lie with the publishers or the external rights holders. [See Legal notice.](#)

**Download PDF:** 19.03.2025

**ETH-Bibliothek Zürich, E-Periodica, <https://www.e-periodica.ch>**

**Remaining Carrying Capacity of Temporary Steel Bridges**  
**Capacité restante des ponts provisoires en acier**  
**Resttragfähigkeit provisorischer Stahlbrücken**

**Pavol JUHÁS**  
Prof. Dr.  
Technical University  
Košice, Slovakia



P. Juhás, born 1941, got Ing. degree at TU Bratislava, CSc. and DrSc. at Slovak Academy of Sciences. He deals with special problems of stability, plasticity and fatigue of steel structures. He is senior scientist at ICA SAS and the Professor at TU Košice.

**Emília JUHÁSOVÁ**  
Dr. Eng.  
Inst. of Constr. and Archit. SAS,  
Bratislava, Slovakia



E. Juhásová, born 1942, got Ing. degree at TU Bratislava, CSc. and DrSc. degrees at Slovak Academy of Sciences. She works as senior scientist at ICA SAS, with specialization on dynamics and seismic isolation of structures.

#### **SUMMARY**

The paper discusses the problems of fatigue life-time and failure of special steel elements adopted as structural components of temporary steel bridges. Attention is paid to properties and variations of loading effects occurring in actual conditions of bridge structures studied. The main results of extensive fatigue tests of steel elements studied are described and discussed. The presentation of a new cumulative conception for the calculation of the fatigue life-time is submitted.

#### **RÉSUMÉ**

Cet article analyse des problèmes de fatigue et de la rupture des éléments d'acier spéciaux qui sont utilisés dans les ponts provisoires en acier. L'attention est portée aux qualités et aux changements des charges se trouvant sur les ponts réels. Dans cet article on décrit et analyse des résultats principaux des vastes essais de fatigue. On y présente une nouvelle conception cumulative du calcul de la durabilité des constructions provisoires en acier.

#### **ZUSAMMENFASSUNG**

Der Beitrag diskutiert die Probleme der Ermüdungslebensdauer und des Kollapses von speziellen Stahlelementen, die als Komponenten provisorischer Stahlbrücken verwendet werden. Besondere Aufmerksamkeit wird den Eigenschaften und Variationen der Belastungseinflüsse geschenkt, die unter tatsächlichen Bedingungen vorhanden sind. Die Hauptresultate von ausführlichen Ermüdungsversuchen der Stahlelemente werden dargelegt. Ein neues kumulatives Konzept für die Berechnung der Ermüdungslebensdauer der provisorischen Stahlbrücken wird präsentiert.



## 1. INTRODUCTION

Nearly in every country we can meet special steel elements which are intended to be used as components of temporary bridge structures during the reconstruction of existing bridges or for special transport purposes. After some short time of service they are disassembled and stored for another utilization. After certain time periods it is necessary to decide what is their remaining carrying capacity and whether they can be used again with sufficient degree of reliability. Similar problems can arise in the case of such steel elements which were produced with some degree of defects as notches, small cracks, geometrical imperfections, etc. In our paper we deal with the results obtained from the tests and analyses of assembled elements of czechoslovak temporary steel bridges. Two assembly bridge systems were tested. In the first system one from the tested elements was previously used in the temporary bridge during the reconstruction of the tram bridge for the period of two years. Others of them did not fully answer to conditions of safety due to initial production defects. The second system was later developed with an intention to replace the first system. Due to results of our tests its details and a production technology were modified and improved.

## 2. PROPERTIES OF LOADING IN ACTUAL AND LABORATORY CONDITIONS

Dynamic fatigue loading of bridges is caused in large degree by variable combined static-dynamic actions from different vehicles moving through the bridge. Some dynamic loading can be caused by natural effects as are strong winds and earthquakes. Then the dynamic loading process of bridges is random stationary or non-stationary. As a base for the analysis of dynamic loading properties we can use time records of accelerations, velocities, deflections, strains, etc. Dynamic measurements on structures and in laboratory need a wide assortment of different devices such as pickups, amplifiers, recorders, computers with A/D and D/A convertors, appropriate softwares, etc.

A random stochastic process as a continuous random function of a non-random variable  $t \in (-\infty, \infty)$  may be written as a set  $X(t)$ , where  $X(t) = x_1(t), x_2(t), \dots, x_i(t), \dots$ , in which  $x_i(t)$  ( $i=1, 2, \dots$ ) are realizations of random process. Having realizations  $x_i(t)$  we can calculate for each of them all necessary characteristics as distribution functions, probability densities, correlation functions, power spectral densities, transfer functions, coherence functions, etc., due to the purpose of analysis [5], [6]. Frequency distribution in power spectral density is influenced by properties of the source loading, e.g. from the motion of vehicles, and by dynamic properties of the bridge structure alone. In Fig. 1 we can see acceleration records in the mid-span of tram bridge points 10, 10 and chosen power spectral densities. When passing from acceleration to velocity or deflection spectrum, the peaks in upper frequency region are falling down as can be seen in Fig. 1-A. This record was obtained from the motion of the sole heavy truck through the bridge. The fluent motion of heavy vehicles can cause the vibrations which are nearly harmonic with narrow frequency band [7]. When using piezoelectric measuring system with primary acceleration measurements it is convenient to apply modified integration according to algorithms described in [6]. The obtained frequency distribution is important for the fatigue analysis when following the expected number

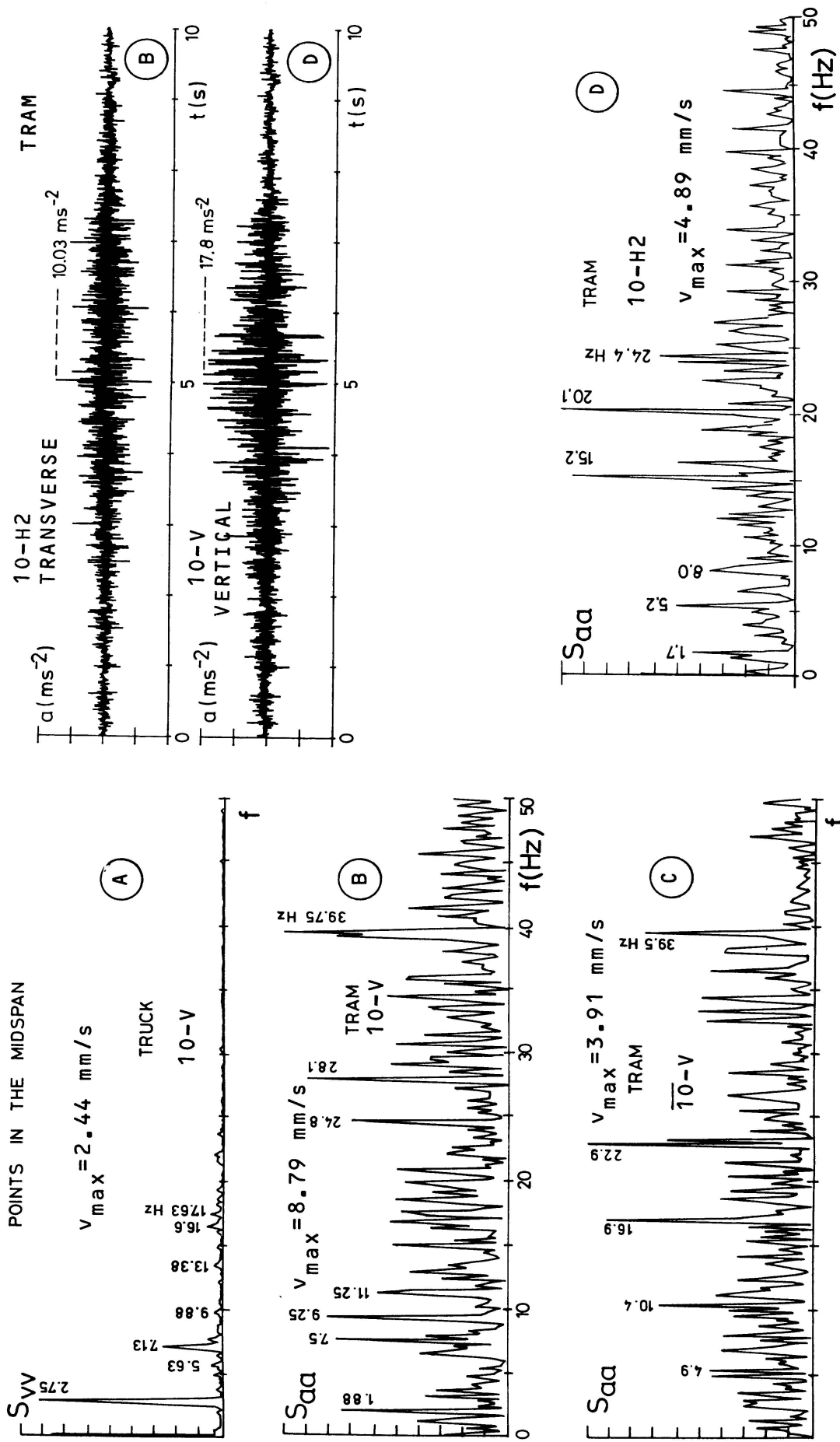

Fig. 1. Vibration of a tram bridge. Time records and power spectral densities ( $S_{aa}$  determined from acceleration records,  $S_{vv}$  from velocity records)



of cycles and frequency components with larger amplitudes. Dynamic measurements give usually informations only about dynamic component of deformation. Then for laboratory fatigue tests we use the combination of measured and calculated values. In laboratory conditions we can apply actual loading processes directly through the simulation of a chosen loading, or we can apply one level or multi-level harmonic loading with the prescribed spectral distribution [1], [2], [8], [9], [11].

### 3. LABORATORY TESTS AND THEIR RESULTS

Experimental verification of the fatigue strength and the life-time of steel bridges is not usually available on full-scale structures. Technical and time factors are decisive. The technical and spatial facilities are also limiting factors for the fatigue tests of full-scale bridge structures in special laboratories. Therefore, the fatigue strength and life-time of steel bridges is often investigated on their models. The transfer of conclusions and results from model tests into actual structures can be problematic. This is, however, very problematic in the cases of determination of total and remaining fatigue life-time of already exploited bridge structures with certain constructional influences and production-technological defects or cracks.

In Czecho-Slovakia the special assembly bridge systems for temporary repeated exploitation have been developed and produced. Due to originality of technical solution, valid standards and former scientific knowledge have not enabled to determine their total and remaining fatigue life-time. The connecting bolts and areas of individual assembly elements have been especially problematic from the view of fatigue strength and failure. Therefore, the experimental verification of these phenomena was realized at our Institute [1], [2], [10].

Our laboratory enables to realize static-dynamic tests of structures and their elements with constructional length up to 18 m. It was not enough for the test of the whole bridge system, therefore, only individual assembly elements were tested in special configuration (Fig. 2). The aim of this was to simulate the design loading of investigated connecting bolts and areas near connections.

In the first stage the static successive and repeated loading of system was realized by one or two forces until  $P = P_u$ , where  $P_u$  is a theoretical ultimate static load, the effect of which corresponds to the effect of design loading on full scale bridge structures. Deflections  $v$  and strains  $\varepsilon$  were measured in chosen points of flanges, webs and stiffeners. Then fatigue tests were realized, with loading  $P(t) = P_0 + P_1 \sin(2\pi ft)$ ,  $P_0 = (P_{\max} + P_{\min})/2$ ,  $f = 5 \text{ Hz}$ ,  $P_1 = (P_{\max} - P_{\min})/2$ .

The fatigue tests continued in stages with interruption after every 50 000 or 100 000 cycles, when the systems were controlled both visually and through the computer. Controlled values were deflections and strains for load levels  $P=0$ ;  $P_{\min}$  and  $P_{\max}$ . The differences in strains indicated beginning of cracks and their position. After appearance of cracks their successive increasing was recorded with investigation of their influence on the system behaviour. The tests continued until the failure of systems.

From system 1 there were tested five assembly elements. Every element was tested twice in cantilever composition. It means

following the behaviour of both its ends in position a or b in Table 1. The element, previously used in the tram bridge, had already visible fatigue cracks in the place of connections. The others were chosen from stocks. From fatigue tests six different types of cracks were ascertained - A up to F, as can be seen in Fig. 2. The decisive cracks and total numbers of cycles  $N$  for individual elements and tests are in Table 1.

Table 1. The results of fatigue tests of system 1.

Indication		MS0	MS1	MS2	MS3	MS4	
Position	a	cracks	C	A, E	D	F	B
		N	1 150 000	1 160 000	1 170 000	585 000	1 010 000
	b	cracks	A	D	F	F	F
		N	680 000	1 820 000	750 000	260 000	565 000

For system 2 previously four elements were tested with interchanging of their ends. All these tests finished with fatigue cracks in places of tension connections of types A and B from Fig. 3. On the base of obtained results the modification of technology was recommended. Then next four tests with another four elements were realized. Here arose new types of fatigue cracks C, D and E, which were decisive for the failure of the whole system (Fig. 3). Total numbers of cycles  $N$  and decisive cracks are in Table 2.

Table 2. The results of fatigue tests of system 2.

Indication		MS1	MS2	MS3	MS4	
Element	I	cracks	-	-	C	C
		N	-	-	2 223 000	1 850 000
	II	cracks	C	D	-	-
		N	3 380 000	3 690 000	-	-

The knowledge and results of presented laboratory tests were used for the determination of the total and remaining fatigue life-time of verified temporary steel bridge systems. Owing to the small number of tests and their character, the obtained results could not be, however, sufficient and competent theoretical accesses. It means to apply them together with the standards data in the fatigue analysis.

#### 4. FATIGUE STRENGTH AND LIFE-TIME

The antecedent standards for the judgement of fatigue strength and life-time of bridge structures have considered a harmonic loading with constant amplitude. Also experimental fatigue verification has been mostly realized with this type of loading. But, as we have mentioned previously, actual steel bridges are subjected to variable-amplitude loading.

Much activity has already been concentrated on the development of a fatigue design method for service variable-amplitude loading. The result of it is a definition of the effective constant-amplitude stress, which allows to use the constant-amplitude relationships for the variable-amplitude load conditions. Palmgren-Mi-

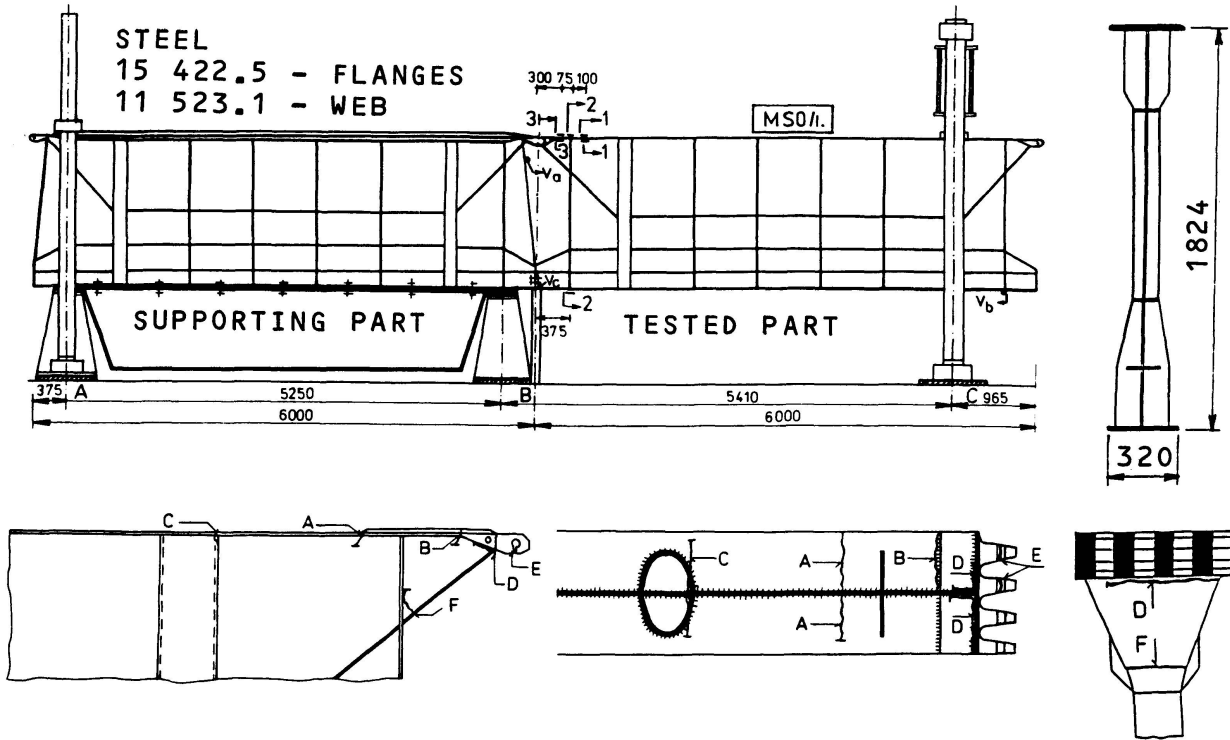

Fig. 2. Static and geometric scheme of test system 1. Positions of fatigue cracks.

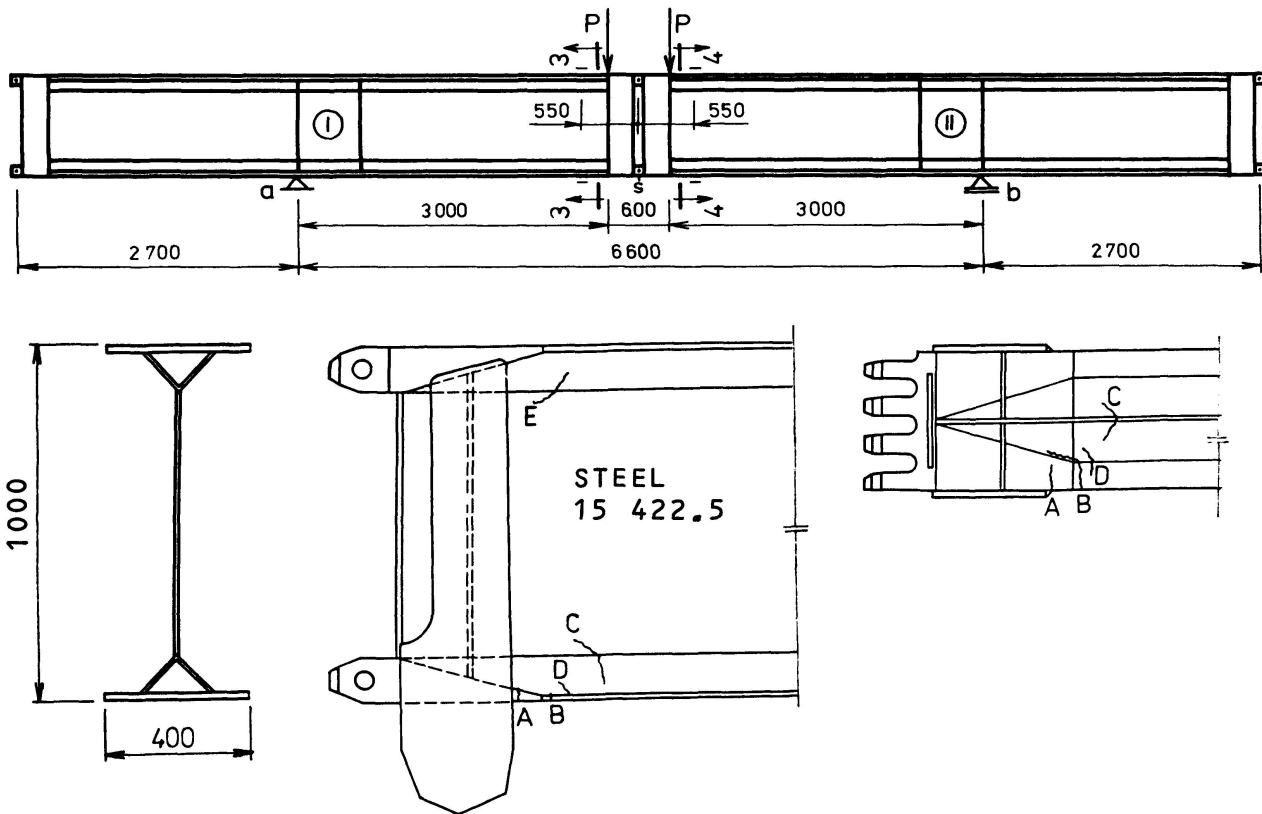

Fig. 3. Static and geometric scheme of test system 2. Positions of fatigue cracks.

ner's linear summation is usually used for accounting the cumulation of fatigue damage caused by variable-amplitude loading. It is generally known that Palmgren-Miner's cumulative rule is not sufficiently accurate. In our Institute the extensive experimental program has been realized for verification of some cumulative assumptions and fatigue design methods [3], [4], [8], [9]. The result of this program is a new conception for the determination of the fatigue life-time.

In the case of constant harmonic loading the fatigue life-time can be determined from experimental or standard fatigue curve concerning the most exposed place of structure. The stochastic stationary loading can be expressed in simplified way using loading spectra with different double stress amplitude  $\Delta\sigma_i$  and answering number of cycles  $n_i$ . Considering constant harmonic loading with  $\Delta\sigma_{\max}$  we can state from responsible fatigue curve the minimal number of cycles  $N_{\min}$ . It means that according to the prevailing influence of variable amplitude loading the total number of cycles  $N$  should be higher than  $N_{\min}$ .

We have used our obtained results like a basis for the new determination of fatigue life-time using  $N_{\min}$ ,  $\Delta\sigma_{\max}$  and aggressivity of loading  $\bar{r}$ :

$$\bar{r} = \sum_{i=1}^s \frac{\Delta\sigma_i}{\Delta\sigma_{\max}} \frac{n_i(1)}{n(1)} \alpha_i \leq 1, \quad (1)$$

where  $\sigma_{\max}$  is maximum double stress amplitude,  $n_i(1)$  is the number of cycles for individual loading levels and  $n(1)$  is total number of cycles in one block loading.

For constant harmonic loading  $\bar{r} = 1$ . Coefficient  $\alpha_i = 1$  for  $\Delta\sigma_i > \Delta\sigma_0$ ; and  $\alpha_i < 1$  for  $\Delta\sigma_i < \Delta\sigma_0$ .  $\Delta\sigma_0$  is defined as the limit fatigue stress. Due to obtained test results when  $\Delta\sigma_i < \Delta\sigma_0$  it answers very well  $\alpha_i = 0.8$ . Therefore we recommend for the determination of total number of cycles  $N$ :

$$N = N_A = N_{\min} / \bar{r}^k, \quad (2)$$

where

$$k = (1 + \bar{r}^2) (3.25 - \bar{r}) \quad (3)$$

and the total life-time  $T_A$

$$T_A = N_A / n(1) \quad (4)$$

When calculating the life-time of the lower chord of the railway steel-bridge [2] we can compare the results of different fatigue conceptions [8], [9], where

- authors:  $T_A = 10.506$  years,
- Palmgren-Miner:  $T_{PM} = 9.721$  years,
- SVUM:  $T_{SM} = 4.347$  years,
- ČSN 73 6205:  $T_{\check{C}SN} = 7.130$  years.

It can be seen that authors' fatigue life-time is larger than that which is supposed due to valid standard demands. Moreover, from the analysis and comparison of results it follows that the theoretical life-time, described by number of cycles  $N_A$  is more close to experimental results  $N$  than the theoretical ones  $N_{PM}$





or  $N_{SM}$  determined according hypothesis Palmgren-Miner and SVUM.

## 5. CONCLUSION

The total and remaining fatigue life-time is very relevant for the reliable exploitation of assembled temporary steel bridges. The fatigue of these structures depends on many factors as are in particular actual service loading process, material characteristics, geometrical parameters, constructional solution, production-technological effects and defects. All these factors are, of course, random variables. Therefore, the exact judgement of fatigue strength and the determination of the life-time for such structures is problematic also nowadays. In cases of original pretentious steel bridges, as those presented in the paper, the experimental verification is inevitable. The appropriate simulation of actual conditions and characteristics is, however, very important for the reliable results. Our proposed approach to the total and remaining fatigue life-time determination concerns variable multi-level loading. For general cases it can be determined using the value of minimum life-time in the case of maximum loading together with the application of aggression effect of the whole loading spectrum. The fatigue life-time is then appropriately increased. The new conception is accounting for the influence of general loading process. It is more exacting than the application of usual linear cumulation hypotheses.

## REFERENCES

1. JUHÁS P. et al., Static-Dynamic Tests of Elements for Temporary Steel Bridges. [Expert Report]. ICA SAS Bratislava, May 1987.
2. JUHÁS P. et al., Fatigue Tests of Elements for Temporary Steel Bridges. [Expert Report]. ICA SAS Bratislava, Feb 1989.
3. JUHÁS P., New Cumulative Conception for Calculation of Fatigue Life-Time. In: Proc. 10th Congr. Material Testing, Budapest 1991.
4. JUHÁS, P., Fatigue Life-Time of Steel Structures. Stav. Čas. 39, No. 11/1991.
5. JUHÁSOVÁ E., Diagnostics of Dynamic Properties of Structures. [Research Report]. ICA SAS Bratislava, Nov 1987.
6. JUHÁSOVÁ E., Seismic Effects on Structures. Elsevier, 1991.
7. JUHÁSOVÁ E., Induced Vibrations from the Transport on Bratislava SNP Bridge. In: Traffic Effects on Structures and Environment, The Low Tatras, April 1991.
8. JUHÁS P. and JUHÁSOVÁ E., Fatigue Life-Time and Mechanism of Failure of Thin-Walled Hybrid Steel Girders. In: Proc. Intern. Symp. on Fatigue and Fracture in Steel and Concrete Structures. SERC CSIR India, Madras, Dec 1991.
9. JUHÁSOVÁ E. and JUHÁS P., Dynamic Loading and the Fatigue Life-Time of Bridges. In: Proc. of Conf. Theory and Construction of Bridges, SvF VŠDS Žilina, Donovaly, Low Tatras, June 1992.
10. JUHÁS P. and KRIVÁČEK J.: Experimental Verification of the Fatigue Life-Time of Steel Bridges. In: Proc. of Conf. Steel Bridges '91, CSOK and SUDOP Hradec Králové, Nov 1991.
11. SMITH I.C.F., CASTIGLIONI C.A. and KEATING P.B., Analysis of Fatigue Recommendations Considering New Data. IABSE Proceedings, P-137/89.