

**Zeitschrift:** IABSE reports = Rapports AIPC = IVBH Berichte

**Band:** 73/1/73/2 (1995)

**Artikel:** Connection of old concrete with new concrete-overlays

**Autor:** Münger, Fritz / Wicke, Manfred / Jirsa, James O.

**DOI:** <https://doi.org/10.5169/seals-55324>

### **Nutzungsbedingungen**

Die ETH-Bibliothek ist die Anbieterin der digitalisierten Zeitschriften. Sie besitzt keine Urheberrechte an den Zeitschriften und ist nicht verantwortlich für deren Inhalte. Die Rechte liegen in der Regel bei den Herausgebern beziehungsweise den externen Rechteinhabern. [Siehe Rechtliche Hinweise.](#)

### **Conditions d'utilisation**

L'ETH Library est le fournisseur des revues numérisées. Elle ne détient aucun droit d'auteur sur les revues et n'est pas responsable de leur contenu. En règle générale, les droits sont détenus par les éditeurs ou les détenteurs de droits externes. [Voir Informations légales.](#)

### **Terms of use**

The ETH Library is the provider of the digitised journals. It does not own any copyrights to the journals and is not responsible for their content. The rights usually lie with the publishers or the external rights holders. [See Legal notice.](#)

**Download PDF:** 02.04.2025

**ETH-Bibliothek Zürich, E-Periodica, <https://www.e-periodica.ch>**

## Connection of Old Concrete with New Concrete-Overlays

Liaison entre ancien et nouveau béton

Verbinden von altem Beton mit neuem Beton

### **Fritz MÜNGER**

Civil Engineer  
Hilti AG  
Schaan, Liechtenstein

### **Manfred WICKE**

Professor  
University of Innsbruck  
Innsbruck, Austria

### **James O. JIRSA**

Professor  
University of Texas  
Austin, TX, USA

Fritz Münger, born in 1944, graduated with a degree in civil engineering from the Swiss Fed. Inst. of Technology, Zurich in 1968. For 20 years he has worked in Switzerland and South Africa as a design engineer in industrial and bridge construction. Since 1989 he has been a project manager with Hilti Corporate Research.

Manfred Wicke, born in 1933, has his civil engineering and Ph.D. degrees from Vienna Technical University. He worked in and later headed the design office of a firm primarily involved in the design of buildings, bridges and power plants. Since 1971 he has been a full professor for concrete structures at Innsbruck University.

James O. Jirsa, born in 1938, graduated from the University of Nebraska with a BS degree in civil engineering. He received M.S. and Ph.D. degrees from the University of Illinois. After teaching at Nebraska and Rice Universities, he has been professor at the University of Texas since 1972.

### **SUMMARY**

If a new layer of concrete is applied to existing concrete with the aim of strengthening or repairing a structure, the result is a composite structure. The bond interface can crack even if the design and the work is carried out carefully. The forces must then be carried with the aid of reinforcement passing across the interface. This paper describes a simple computational model and corresponding tests with a new type of mechanical connector.

### **RÉSUMÉ**

Si l'on ajoute une nouvelle couche de béton sur une construction en béton afin de renforcer celle-ci, il en résulte une construction mixte. Même si l'exécution est très soignée, il arrive que le joint soit fissuré. La transmission des forces à travers le joint doit se faire à l'aide d'une armature. Cet article présente un modèle de calcul simple ainsi que les essais correspondants avec des connecteurs mécaniques.

### **ZUSAMMENFASSUNG**

Wird eine neue Betonschicht auf eine bestehende Betonkonstruktion aufgebracht, in der Absicht, das Tragwerk zu verstärken oder instandzusetzen, so entsteht ein Verbundtragwerk. Auch bei sorgfältiger Arbeit kann es geschehen, dass die Verbundfuge reißt. Die auftretenden Kräfte müssen dann mit Hilfe einer Bewehrung durch die Fuge geleitet werden. Die vorliegende Arbeit berichtet über ein einfaches Rechenmodell und entsprechende Versuche mit mechanischen Verbindungsmitteln.



## 1. INTRODUCTION

The demand for the strengthening of concrete structures is rapidly increasing. This is in part due to changes in the use of, or increases in the service loads for structures, but also results from the growing need for repair of damage and wear. In many cases, a loadbearing layer of new concrete (overlay) is applied over the existing concrete structure. This overlay is usually placed as cast- or pneumatically-placed concrete. It can work to augment either the flexural compression or tension zones, depending on reinforcement and placement (see Fig. 1).

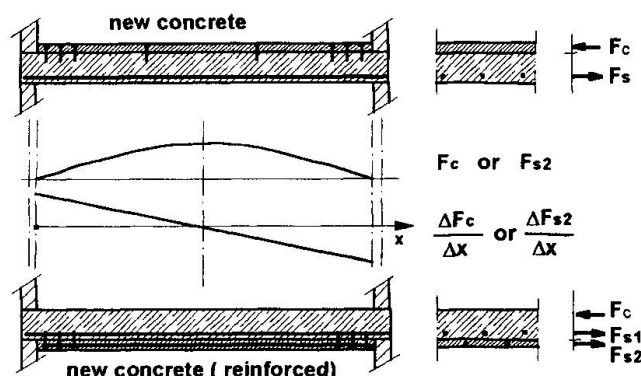

Fig. 1 Examples for the method of strengthening

## 2. STATUS OF COMPUTATION METHODS

Initially, the stresses in the bond interface result from a combination of external loads and internal restraint forces. Fig. 2 shows the development of internal stresses resulting from shrinkage and temperature gradients in the new concrete. Note that these stresses are typically maximum at the slab edges. The combination of external and internal

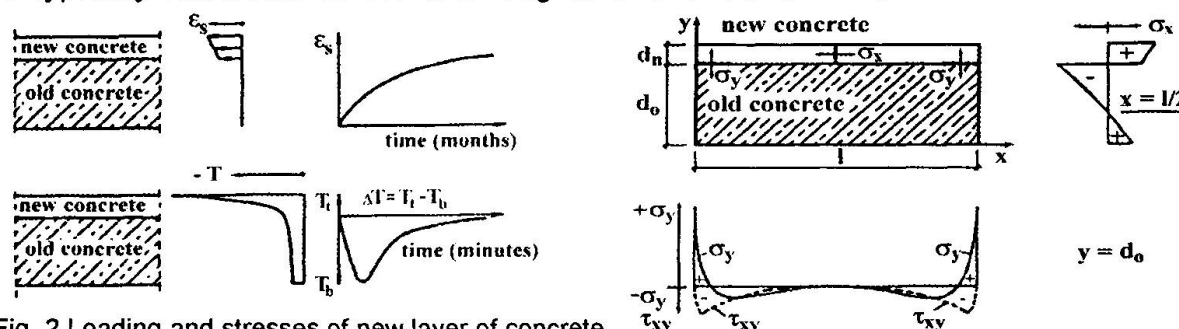

Fig. 2 Loading and stresses of new layer of concrete

stresses often exceed the capacity of the initial bond, thus requiring the designer to consider a cracked interface. This is particularly true in the case of bridge overlays which are subjected to fatigue stresses resulting from traffic loads. Furthermore, these stresses are dependent on time and bond failure can take place years after overlay placement.

If the bond interface is cracked, the stresses may be considered to result from external loads only, since the cracked interface releases the internal stresses. This assumption requires reinforcement to cross the bond interface in order for shear transfer to occur, a necessary condition for the monolithic design of the section.

Improvement in the performance of the bond between new and old concrete can be achieved by (a) careful preparation of the old surface (b) formulating a special, low-shrinkage concrete or a concrete made from low-heat cement or (c) through suitable methods of placement, such as pneumatically-placed concrete. Furthermore, chemical primers and bonding slurries can be used. It must then be borne in mind that even if the bond is made properly, i.e. the strength of the bond is the same as that of the base material, the underlying concrete may fail anyway. In many cases, failure of the bond can also be attributed to sub-standard work or unrealistic requirements for work execution.

In jobsite practice, it has been found that the stringent requirements for both planning and execution are not met in many cases. As a result, design standards usually require very low shear stresses unless transverse reinforcement is provided to facilitate transfer of the shear force through the bond layer. Such mechanical transfer is also required by





optimum balance between the roughness requirements and the number of connectors must be achieved. The effect of surface roughness has an upper limit which is given by fracture of the new or the old concrete adjacent to the interface zone.

\* The **stiffness under tension  $S_t$**  of the connector depends on its cross-sectional area and length as well as the effectiveness of its anchorage in the two layers of concrete. The stiffness is decisive for the tensile force that results from a certain **crack width  $w$** . The crack width, in turn, is limited by the surface roughness. If serviceability requirements limit the crack width, stiffer connectors must be employed.

For laboratory tests, the following aspects are of note: It is best for the trussed

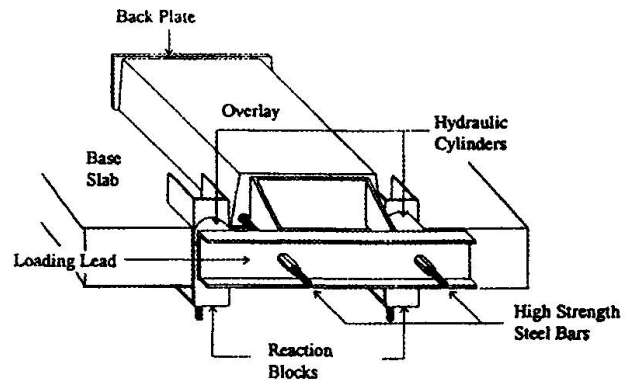

Fig. 4 Shear test (Choi [9])

framework model to be segregated into tension and compression lines of action. The large number of influencing factors can then be sorted out and studied through simple tests.

First, simple pull-out tests of the connectors are carried out to determine the stiffness and ultimate loading capacity of the connectors. The parameters to be investigated are the concrete compressive strength  $f_c$ , the mode of anchorage in the old concrete, and the anchorage in the new concrete as determined by the anchor geometry.

The transmission of shear is then studied during pure shear tests. For these tests, the surface roughness, the normal stress in the bond and, again, the concrete compressive strength, are varied. When carrying out the shear tests, particular care must be taken to ensure that no secondary trussed frameworks are induced by the transfer of loads and that the two layers of concrete can move away from each other with parallel crack edges. Figures 4 and 5 show typical arrangements for shear tests. The overall performance is then studied by conducting building component tests.

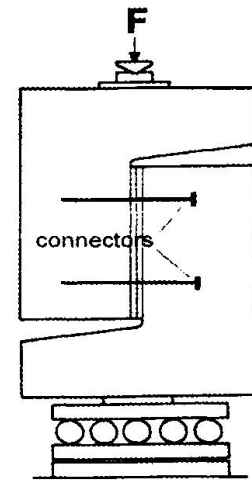

Fig. 5 Shear test (Walraven [4])

#### 4. INVESTIGATION OF APPLICABILITY OF EXPERIMENTAL HILTI JUMBO-NAILS TO FAST-TRACK BONDED CONCRETE OVERLAYS

An investigation has been performed at the Fergusson Structural Engineering Laboratory (FSEL) at the University of Texas at Austin. The objective was to study the use of the experimental Hilti Jumbo-Nail to permit construction of fast-track bonded concrete overlays when environmental conditions endanger the development of bond between the substrate and the overlay, or as a means to limit or eliminate substrate surface preparation. The concept of the Hilti Jumbo-Nail is derived from powder-actuated fastener technology. It provides for rapid installation of dowel-like fasteners without chemical adhesives, thus reducing labor and material costs and permitting immediate placement of new concrete.

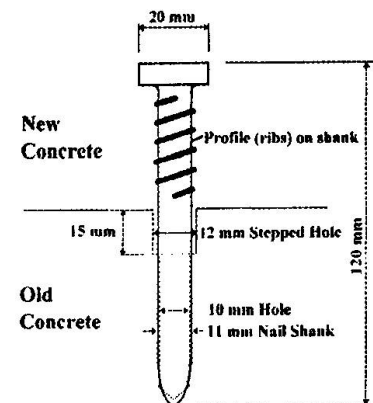

Fig. 6 Hilti Jumbo-Nail

A number of tests have been conducted to study the effectiveness of the Hilti Jumbo-Nail for controlling overlay cracking and preventing or arresting delamination [8] [9].

The test program for the pull-out tests was designed to simulate field conditions as closely as possible. Variables such as the concrete strength, the location of the nail with respect to the edge of the slab, cracks in the concrete, or other conditions that would normally be encountered during the application of the nails were studied along with as well as subtle variations from the recommended installation procedure. 336 pull-out tests were performed, and the results (Fig. 7) are documented by Colecchia [8].

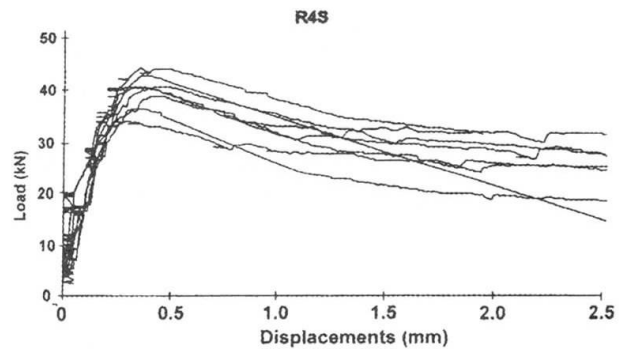

Fig. 7 Example for pull-out tests

The nail pull-out test results show that an edge distance of 215 mm is necessary for a Jumbo Nail driven into 30 MPa concrete to develop full pull-out strength. Accordingly, a Hilti Jumbo Nail shear test specimen would require overall dimensions considerably larger than those of a standard shear test. It was therefore decided to devise an „in-situ push-off test“. Replicates of four concrete slabs used for the pull-out tests were used as

the base slabs. The overlays were cast on top of the base slabs and cured. Up to sixteen overlays were cast on each base slab (Fig. 8). Advantages of the in-situ push-off test method are that many test specimens can be made using one set of forms and the shear test can be performed in-place as soon the overlay gains the desired strength. 116 overlays were cast and tested over a period of 12 months. The results are documented by Choi [9].

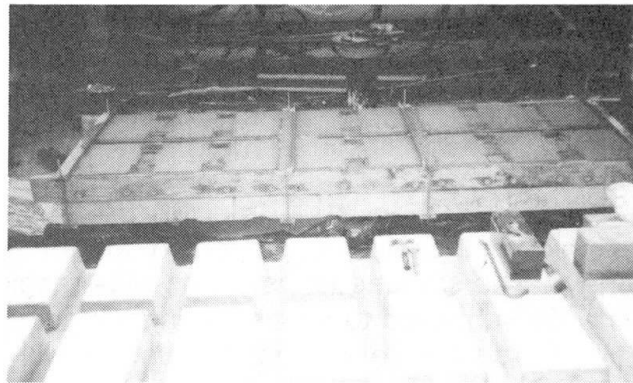

Fig. 8 In-situ shear tests of Hilti Jumbo Nails

It should be noted that all overlays were cast against the dry top surface of the base slab in this study. Since the moisture condition on a base slab can only be decided qualitatively before placement of an overlay, it was decided to keep all interfaces dry to eliminate the effect of moisture from the test results. The top surface of the base slab was roughened and the overlay cast on the roughened surface for most test specimens. For some test specimens, the overlay was cast on the relatively smooth troweled surface of the base slab. The reinforcement ratio was controlled through the use of a template and the placement of single or paired nails. The minimum reinforcement ratio was 0.13% and the maximum was 0.38%.

The test variables included: (a) the compressive strength and aggregate type of the base concrete, (b) the roughness of the interface and (c) the presence of cracks in the base slab. A number of flexural cracks was created on one face of the base slabs. In some tests, the adhesion between the base concrete and the overlay was intentionally broken using a bond breaker and some tests were performed early to analyse early-age interface shear strength development. The test results of two unbonded specimens and two bonded specimens are plotted for comparison in Fig. 9. All four test specimens had the same contact area and used paired nails ( $\rho = 0.38\%$ ). The shear load versus horizontal displacement plots of unbonded test specimens did not show the sharp peaks previously encountered with bonded test specimens.



Fig. 9 shows that the unbonded specimens using paired nails were effective in limiting the horizontal displacement to small values when the applied shear loads are relatively low. The magnitude of shear loads in the relatively flat plateaus in bonded specimens and unbonded specimens are similar at larger displacements. This is important for relief of shrinkage stresses in the layer of new concrete.

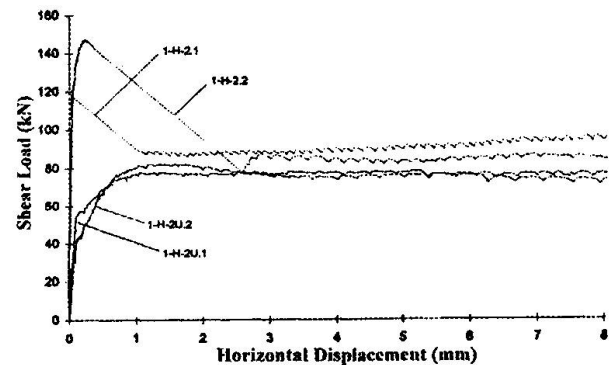

## 5. DESIGN CONSIDERATIONS

Fig. 9 Example for shear tests

For concrete overlays, the model shown in Fig. 3 provides a suitable design basis. The following applies fundamentally: the design resistance of the connectors and the compressive tie must be at least equal to the design value of the tensile and compressive forces calculated from the actions. The partial safety factors for resistance must be stipulated according to the mode of failure. The tensile force in the vertical component of the strut is carried by the resistance of the connector. The number of connectors per unit of area is calculated from the area over which the connectors are effective. Installing connectors over a large area can be avoided if the shear force set up by external actions is low. In such cases, however, connectors are still required in the edge zones owing to the unavoidable forces of constraint. The force to be resisted by the connectors is then calculated from the tensile force which corresponds to concrete cracking in the overlay.

## 6. SUMMARY

A simple methodology is presented for the design of shear connectors in concrete overlays. The strut model used has wide-ranging application for concrete-concrete bond interfaces subjected to shear loading. Ongoing research in this field is being conducted by Hilti Corporate Research in conjunction with its partner Universities.

## LITERATURE

1. **AASHTO**, Standard Specifications for Highway Bridges. The American Association of State Highway and Transportation Officials, Washington, 1989.
2. **Seible F., Latham C. T.**, Analysis and Design Models for Structural Concrete Bridge Deck Overlays. *Journal of Structural Engineering* Vol 116, No. 10, October 1990.
3. **Menn C., Brenni, P., Keller Th., Pellegrini L.**, Verbindung von altem mit neuem Beton. Institut für Baustatik und Konstruktion ETH Zürich. Bericht Nr. 193, 1992.
4. **Walraven J. C., Reinhardt H. W.**, Theory and experiments on the mechanical behaviour of cracks in reinforced concrete subjected to shear loading. *Heron* Vol.26/1981.
5. **Nissen I.**, Rissverzahnung des Betons, gegenseitige Rissuferverschiebung und übertragene Kräfte., Dissertation, TU München 1987.
6. **Ruth J.**, Werkstoffverhalten in Grenzflächenbereichen der Tragelemente von Bauwerken., Dissertation, TU Stuttgart 1993.
7. **Tsoukantas S. G., Tassios T. P.**, Shear Resistance of Connections between Reinforced Concrete Linear Precast Elements. *ACI Journal*, May-June 1989.
8. **Collecchia M.**, Tensile Behaviour of Large Powder-Driven Fasteners in Concrete. Thesis. The University of Texas at Austin. August 1994.
9. **Choi D.**, Shear Transfer Test Results of Hilti Jumbo Nails. Unpublished Progress Report. The University of Texas at Austin. December 1994.