

Zeitschrift: Comtec : Informations- und Telekommunikationstechnologie = information and telecommunication technology
Herausgeber: Swisscom
Band: 82 (2004)
Heft: 5

Artikel: New billing capabilities with BRETZEL
Autor: Herce, Fernando Burgo / Schenk, Richard / Doetsch, Markus
DOI: <https://doi.org/10.5169/seals-876867>

Nutzungsbedingungen

Die ETH-Bibliothek ist die Anbieterin der digitalisierten Zeitschriften. Sie besitzt keine Urheberrechte an den Zeitschriften und ist nicht verantwortlich für deren Inhalte. Die Rechte liegen in der Regel bei den Herausgebern beziehungsweise den externen Rechteinhabern. [Siehe Rechtliche Hinweise.](#)

Conditions d'utilisation

L'ETH Library est le fournisseur des revues numérisées. Elle ne détient aucun droit d'auteur sur les revues et n'est pas responsable de leur contenu. En règle générale, les droits sont détenus par les éditeurs ou les détenteurs de droits externes. [Voir Informations légales.](#)

Terms of use

The ETH Library is the provider of the digitised journals. It does not own any copyrights to the journals and is not responsible for their content. The rights usually lie with the publishers or the external rights holders. [See Legal notice.](#)

Download PDF: 30.03.2025

ETH-Bibliothek Zürich, E-Periodica, <https://www.e-periodica.ch>

New Billing Capabilities with BRETZEL

FERNANDO BURGOS HERCE, RICHARD SCHENK AND MARKUS DOETSCH **With BRETZEL, Swisscom Mobile obtains far more flexibility towards new charging models in mobile data services. Due to these advanced billing capabilities, customers can now benefit from the separation of content and bearer charges.**

Mobile operators need to maximise their Average Revenue per User (ARPU) to stay profitable by being more than a mere traffic pipe, and leverage from the value of services running through the data pipe. Until recently, the transport layer for GPRS, WLAN and UMTS was relatively dumb, providing basic IP routing and filtering (firewall) capabilities, but with limited knowledge of the services or applications being transported beyond data volume and time.

With the successful launch of the BRETZEL Platform Project on July 2004, new capabilities were introduced within Swisscom Mobile networks. Such capabilities allow detailed, accurate and real-time information from GPRS and UMTS (2.5G and 3G) traffic at the service and application layer. This establishes the basis for real-time billing and new charging flexibility in postpaid and prepaid data services, providing a comprehensive set of billing options for new innovative services.

Importance of "Service Awareness"

Following the trends seen in the fixed world, mobile connectivity will gradually turn into a commodity as bandwidth increases. Mobile operators must act and focus their attention on the value of services running through the mobile pipes in order to generate new revenue flows.

Until today, typical network infrastructure has supported accurate billing for data services. However, legacy billing infrastructure typically does not provide any knowledge as to which data services are used by our subscribers beyond volume and time metrics. Furthermore, 'hot billing' offline

calculation of service charges does not bring the immediate costs information that customers would prefer during purchasing decisions.

As a result mobile operators are not able to properly position expensive promotional programs and premium content services. In order to close this gap, mobile operators must act to introduce real-time and 'service aware' capabilities on the billing of data services.

BRETZEL Value Proposition for the End Customers

One critical problem in the positioning of data services today are additional traffic charges that customers must pay on top of advertised prices on content (games, ring tones). This problem has also been recognised by Vodafone as one of the causes for the low ARPU generated by Vodafone live!

With the successful launch of BRETZEL Platform Project on July 2004, Swisscom Mobile became one of the first Vodafone operating companies to commercially introduce packet inspection solutions following Vodafone Global IPC (Intelligent Packet Core) guidelines. Such guidelines allow separation of traffic and service charges, thus ensuring the compatibility to Vodafone future IP charging models. This represents a critical step towards a better transparency to customers in the perception of advertised costs versus value of offered services. This smoothed perception in the value of services fulfils the objective of overcoming potential barriers to a steady penetration and uptake of Vodafone live! offering in the Swiss market.

Swisscom Mobile customers can now enjoy browsing within Vodafone live! portal for free (Window-shopping). By simply purchasing a convenient "Portal Pack" subscription (5.00 CHF/monthly for postpaid customers, 7.00 CHF/month for prepaid customers) customers can avoid additional traffic charges when purchasing their favourite Vodafone live! games, ring tones, pictures, etc.

In a second phase, Project BRETZEL will procure the adoption of real-time capabilities for the billing of data products. Such capabilities will provide transparent and instantaneous information on data traffic costs to both prepaid and postpaid subscribers.

New Solutions for Real-Time Billing: Packet Inspection

Before 2002, it was generally assumed that a real-time solution for GPRS and UMTS (2.5G & 3G) should be based on CAMEL Phase 3 (CAMEL3). This assumption has been strongly challenged during the last year due to a number of limitations: lack of "service awareness" (CAMEL3 cannot discriminate between different IP services-MMS, streaming, etc.), lack of support for charging models beyond time

Fig. 1. PI concept.

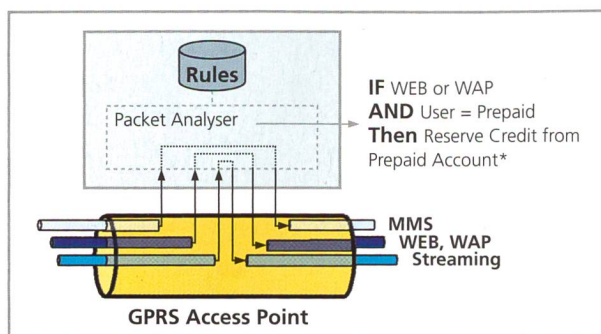

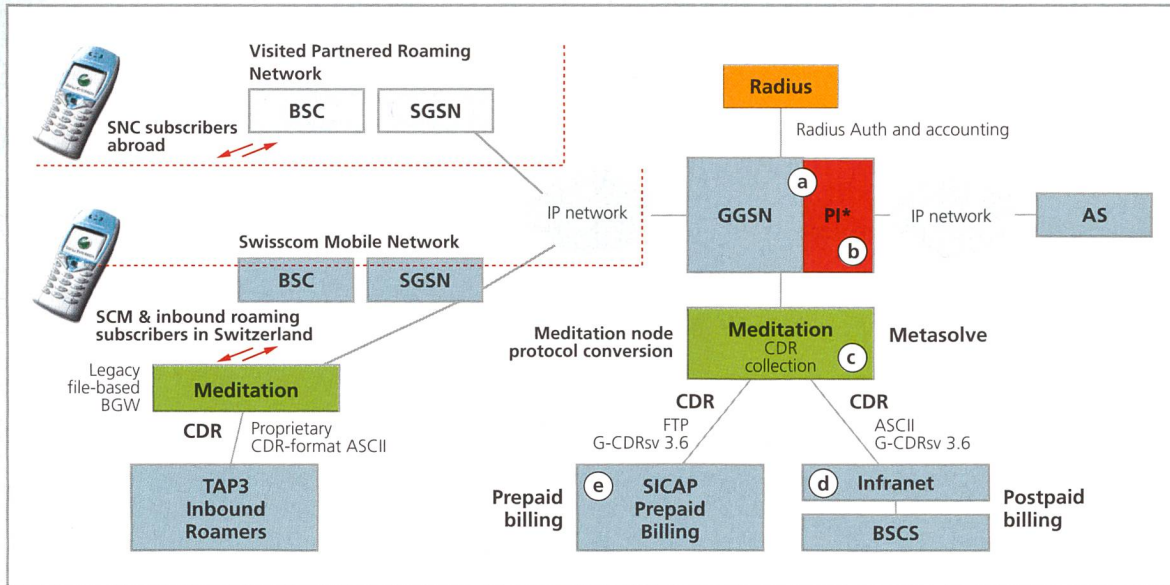

Fig. 2. BRETZEL Solution.

BRETZEL Solution – Switching from S-CDRs to G-CDRs

The introduction of BRETZEL represents a radical transformation in the way billing is achieved today by switching from S-CDRs (CDRs generated in SGSN node) to G-CDRs (CDRs generated in GGSN node).

Prior to the introduction of the BRETZEL Platform, the billing of PS data traffic was based on S-CDRs. The information contained on S-CDRs is mainly limited to time and volume metrics. This restricts the flexibility in charging models, and this transformation of billing by using G-CDRs instead was therefore required.

Project “GGSN replacement” introduced the new Nortel “Intelligent GGSN” within Swisscom Mobile networks (a) on the figure. This new GGSN includes PI capabilities, and was used as the basis for BRETZEL platform capabilities on core networks. Part of BRETZEL activities was to program CBB rules in the GGSN PI engine (b) to properly separate GPRS and UMTS traffic into different PS zones (On-Net, Off-Net, MMS, Download and over-head traffic).

CBB rules in the PI engine work by using an IF THEN ELSE mechanism. When analysing packets in the GPRS/UMTS traffic data flow, the first rule PI gets checked first.

If PS traffic characteristics match the first PI rule, then the traffic is classified within the PS zone associated with the first CBB rule. If not, then the PI engine tries to match PS traffic characteristics with the second CBB PI rule etc.

CBB information is now written in the G-CDRs generated in the Nortel “intelligent GGSN” (Content based billing – CBB information), in other words, CDRs are flagged to indicate to which PS zone IP packets in the traffic data flow belong.

Along with CBB information, CDRs are also flagged in GGSN to indicate whether they belong to prepaid or postpaid PS data services. Using this flag the Metasolve mediation node (c) is responsible to filter and channel the CDRs flow into the correct billing platforms (postpaid billing, Portal Infranet (d) prepaid billing, Sicap PPB (e)).

CBB information in G-CDRs is then used by the billing Platform to rate and bill PS traffic accordingly. However, such G-CDRs including CBB information have a different format in the record extensions, and adaptations were required in existing prepaid and postpaid billing platforms in order to understand CBB information.

and volume metrics; and uncertain deployment plans with-in roaming operators who act as partners.

Packet Inspection (PI) has emerged as alternative to CAMEL3 taken by an emerging class of solutions for GPRS and UMTS real-time billing. This approach is based on the detailed examination of IP packets transported via the PS network. In OSI terminology, PI role is located from the Layer 4 (Transport e. g. TCP) to 7 (Application e. g. HTTP URL). PI has the ability to determine which service or application is being used. In addition to the support of real-time charging of the bearer, these solutions also provide an attractive set of additional capabilities (see two chapters at the end). Figure 1 illustrates the main concept of PI.

Description of BRETZEL Platform Solution

Subsequent to a thorough evaluation process the following solution guidelines were decided for the final solution:

- Combined core network component – “Intelligent GGSN” – including packet inspection capabilities
- Bearer agnostic solution supporting provided capabilities over WLAN, GPRS and UMTS (2.5G and 3G) and HSCSD
- Reuse and adaptation of existing billing platforms: Postpaid – Portal Infranet and Prepaid – Sicap PPB
- Introduction of a transactional mediation node (Metasolve CGF) responsible for the following functions: protocol conversion and filtering of prepaid and postpaid CDRs

- Only one common interface between the network component providing PI capabilities (“Intelligent GGSN”) and rating engine
- Type of information required for charging: session aware, correlation with particular user, discrimination based on protocols used, source & destination, traffic direction (upload & download), port and URL accessed

Commercial Benefits of Packet Inspection

Today the BRETZEL platform is responsible for the separation and billing of PS On-Net and Off-Net traffic. In connection with other platforms, the use of PI with BRETZEL Platform Project can offer the following possibilities:

Single Access Point and APN Management

This allows a reduction of APN maintenance costs (simplified device configuration, reduced APNs testing, reduced customer care support for configuration problems, etc. Furthermore, it permits to bill simultaneously running services (e. g. user sends a MMS message while browsing WAP content).

Service and Application Level Charging

Charging models can be based on diverse correlated information such as traffic IP addresses (source and destinations; used Ports; MSISDNs; content type (e. g. by URL), and traffic protocol type (e. g. MMS, SMTP, Streaming, etc.). The platform is also able to determine whether mobile services are used by customers while roaming (roaming awareness)

Outlook of BRETZEL Platform into the Future

The launch of the Platform Project BRETZEL catalysed a step-change in the design of the Swisscom Mobile networks in a direction significantly more capable in terms of future demands of charging models for mobile data services.

In the future, the value proposition to Swisscom customers can be extended with new capabilities on the BRETZEL platform, namely:

“Free-of-Charge” Prepaid Reload Portal

When the system detects that the existing balance is not enough to purchase desired content or services, the portal will re-direct customers to a “free-of-charge” portal address to top-up their prepaid balance,

Customer Profiling and Connection to CRM Systems

Connecting to CRM systems will allow Swisscom Mobile to understand service usage and trends. This will provide information for a better positioning of future and existing mobile services

Real-Time User Notification

Customers will receive dynamic and instantaneous information concerning traffic redirection, promotions, services costs, etc.

Support of flexible Data Charging Models across different Bearer Technologies

Providing seamless support of billing models across GPRS and UMTS (2.5G, 3G EDGE) and WLAN.

Acknowledgement

The authors would like to thank Xavier Weibel (Technical Operations, Swisscom Mobile) for his kind contribution to this article. ■

Fernando Burgos Herce, General Project Manager (Technical Marketing, Swisscom Mobile)

Richard Schenk, Technical Project Manager (Technical Operations, Swisscom Mobile)

Markus Doetsch, Project Sponsor (Technical Marketing, Swisscom Mobile)

Glossary

APN	Access Point Node
ARPU	Average Revenue Per User
ASCII	American Standard Code for Information Interchange
AS	Application Server
BGW	Billing Gateway
BSC	Base Station Controller
BSCS	Business Support & Control System
CAMEL	Customized Applications for Mobile Network Enhanced Logic
CAMEL3	CAMEL Phase 3 (Standard evolution Phase)
CBB	Content Based Billing
CDR	Call Data Records
CRM	Customer Relationship Management
CTP	Card Telephony Protocol (Nortel Proprietary) Bidirectional Real time Transaction based protocol
EDGE	Enhanced Data for GSM Evolution
FTP	File Transfer Protocol
G-CDR	Call Data Record information generated in GGSN
GPRS	General Packet Radio Service
GGSN	Gateway GPRS Serving/Support Node (also used by UMTS networks)
GSM	Global System for Mobile Communications (cellular phone technology)
GTP	GPRS Tunnelling Protocol
HTTP	Hyper Text Transfer Protocol (World Wide Web Protocol)
HSCSD	High Speed Circuit Switched Data
IP	Internet Protocol
MMS	Multimedia Messaging Service
On-Net	Data traffic (browsing, download, etc.) corresponding to services offered by the operator or by partnered providers
Off-Net	Data traffic (browsing, download, etc.) corresponding to services offered by non-partnered providers
OSI	Open Systems Interconnect
PI	Packet Inspection
PPB	Prepaid Billing Platform
PS	Packet Switched traffic
RADIUS	Remote Authentication Dial-In User Server/Service
S-CDR	Call Data Record information generated in SGSN
SCM	Swisscom Mobile
SGSN	Serving GPRS Support Node (also used by UMTS networks)
TAP	Transferred Account Procedure (transfer protocol for roaming billing)
TCP	Transmission Control Protocol
UMTS	Universal Mobile Telecommunications System
URL	Universal Resource Locator
VPN	Virtual Private Network
WAP	Wireless Application Protocol
WLAN	Wireless Local Area Network

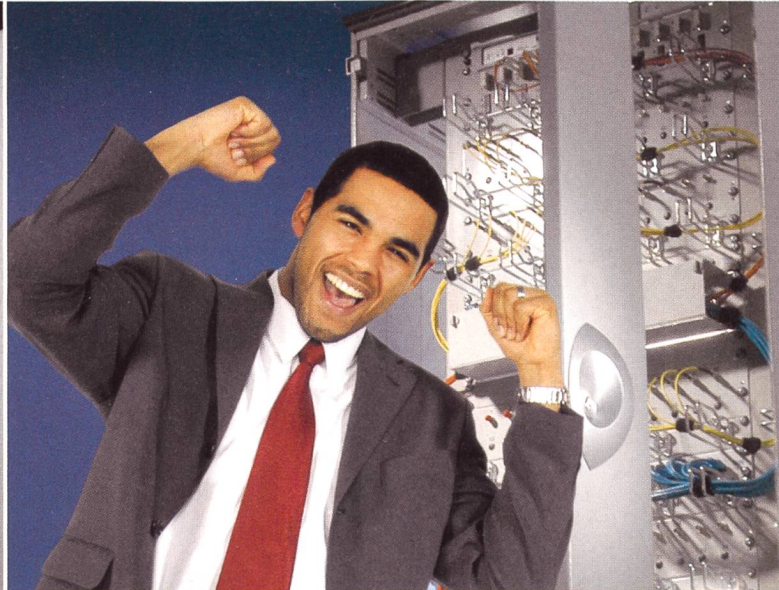
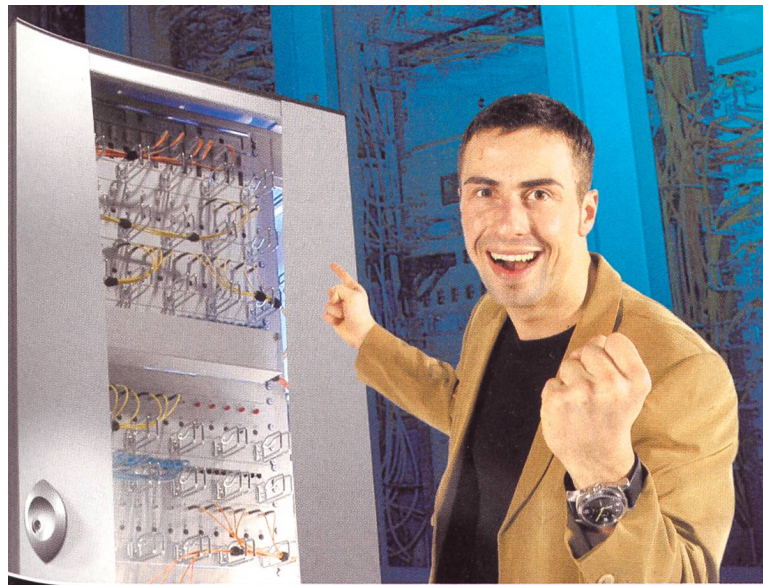

one world

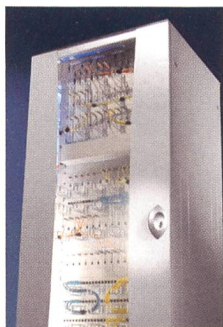

one rack

RITTAL TE 7000 TOP EFFICIENCY: DAS GLOBAL-IT-RACK.

Konzipiert auf der Grundlage jahrzehntelanger Rack-Kompetenz, entspricht der Rittal TE 7000 *internationalen Standards*. Mit seiner intelligenten Bauweise lässt er sich in Rekordzeit aufbauen – von nur einem Netzwerkspezialisten. Das in seiner Einfachheit überzeugende Rack bietet ein *umfangreiches Systemzubehör* und lässt sich bei Bedarf individuell umrüsten. Für Schnelligkeit im Handling sorgen der überragende Nutzerkomfort und einzigartige *Access-, Climate- und Security-Konzepte*.
Rittal AG, 5432 Neuenhof, Tel. 056 416 06 00, www.rittal.ch, rittal@rittal.ch