

Zeitschrift: Elemente der Mathematik
Herausgeber: Schweizerische Mathematische Gesellschaft
Band: 46 (1991)
Heft: 2

Artikel: Placing and moving spheres in the gaps of a cylinder packing
Autor: Kuperberg, W.
DOI: <https://doi.org/10.5169/seals-43268>

Nutzungsbedingungen

Die ETH-Bibliothek ist die Anbieterin der digitalisierten Zeitschriften. Sie besitzt keine Urheberrechte an den Zeitschriften und ist nicht verantwortlich für deren Inhalte. Die Rechte liegen in der Regel bei den Herausgebern beziehungsweise den externen Rechteinhabern. [Siehe Rechtliche Hinweise.](#)

Conditions d'utilisation

L'ETH Library est le fournisseur des revues numérisées. Elle ne détient aucun droit d'auteur sur les revues et n'est pas responsable de leur contenu. En règle générale, les droits sont détenus par les éditeurs ou les détenteurs de droits externes. [Voir Informations légales.](#)

Terms of use

The ETH Library is the provider of the digitised journals. It does not own any copyrights to the journals and is not responsible for their content. The rights usually lie with the publishers or the external rights holders. [See Legal notice.](#)

Download PDF: 01.04.2025

ETH-Bibliothek Zürich, E-Periodica, <https://www.e-periodica.ch>

Placing and moving spheres in the gaps of a cylinder packing*)

Abstract. The closeness of a packing is defined as the reciprocal of the supremum of the radius of a ball contained in the complement of the packing. It is known that the maximum closeness of any packing of R^3 with infinite circular cylinders of radius 1 equals $\varrho^{-1} = 3 + 2\sqrt{3}$, and, up to an isometry, the packing of maximum closeness is unique. We prove that if in a packing no two cylinders are parallel, then, for any two balls of radius ϱ non-overlapping with any of the cylinders, each of the balls can move between the cylinders to assume the other ball's place, without overlapping with any of the cylinders during the motion.

Introduction

First, let us describe the content of this paper in a less rigorous, but more intuitive and visual manner.

Imagine a *forest* in which trees are *cylinders*, each being infinite in both directions and of unit radius. Two such cylinders are allowed to touch, even along a line, but not to overlap. There are various types of forests possible. If all cylinders are parallel, we say that the forest is *straight*, and if no two cylinders are parallel, we say that the forest is *chaotic*. A straight forest in which every cylinder touches six others is of special importance to us. We will call it *the thickest forest*. Our forests shall be inhabited with *porcupines* which are animals of spherical shape. If the ball centered at P and with radius r does not invade any of the cylinders of a given forest, then we say that *there is room at P for an r -porcupine*.

Notice that the maximum radius of a porcupine that can live in the thickest forest is $\varrho = (2/\sqrt{3}) - 1$ (see Fig. 1).

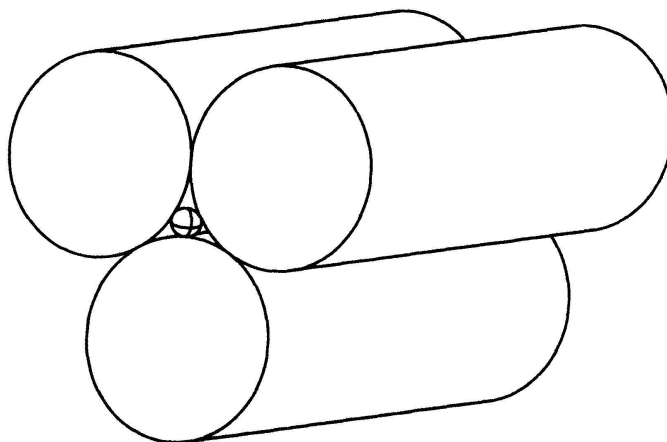

Figure 1.

*) Partially supported by the Hungarian National Foundation for Scientific Research, grant number 1238.

We prove that in every forest there is room for a ϱ -porcupine and, in fact, every point which lies outside all of the cylinders is within $\sqrt{2/3} = 0.816 \dots$ from a point at which there is room for a ϱ -porcupine. Moreover, if there is no room for a porcupine of size greater than ϱ , the forest is the thickest one. In this part we duplicate to some extent the result of [4], but our approach is slightly different and we use it for further conclusions.

Turning to chaotic forests, we prove that a ϱ -porcupine can move freely in it, avoiding all cylinders and being able to arrive at any place at which there is room for it.

A reader familiar with discrete geometry will recognize the concept of packing and its closeness in the above description. Given a set K , then a family of sets K_i , each congruent to K , whose interiors are disjoint, is called a *packing with copies of K* (A forest is a packing with copies of a unit cylinder). Sometimes we identify the packing with the union of all of its members. This identification creates no confusion if K is the closure of its interior. The *closeness* of a packing is measured with the reciprocal of the supremum of the radius of a ball contained in the complement of the packing (see L. Fejes Tóth [3], A. Bezdek [1], K. Böröczky [2], and J. Horváth [4] for definitions and results concerning this notion).

The following sections will be devoted to stating and proving the results described in the introduction, in a more rigorous manner and in the usual, geometric terminology. The number $(2/\sqrt{3}) - 1$, crucial in our investigations, will be consistently denoted by ϱ .

1. Lemmas

Lemma 1. *Among all triangles with all sides of length ≥ 2 , the equilateral triangle of side 2 is contained in a circle of minimum radius.*

This lemma is a well-known fact in elementary geometry with an easy proof.

Lemma 2. *If a disk of radius r intersects three non-overlapping unit disks (all in one plane), then $r \geq \varrho$ and the equality occurs only if the three unit disks are tangent to each other.*

This lemma follows directly from Lemma 1.

Lemma 3. *If a ball of radius r intersects three non-overlapping unit balls (in 3 dimensions) then $r \geq \varrho$, and the equality occurs only if the three unit balls are tangent to each other.*

Proof. This lemma is reduced to Lemma 2 by projecting the four balls on the plane of the centers of the three unit balls.

Main Lemma. *If a ball of radius r intersects of three non-overlapping unit cylinders, then $r \geq \varrho$ and the equality occurs only if the three cylinders are parallel and tangent to each other.*

Proof. In each of the cylinders there lies a unit ball (inscribed in the cylinder) which meets the ball of radius r (see Fig. 2). Obviously, the three unit balls do not overlap. This reduces the proof to Lemma 3. Notice that if the three unit balls are tangent to each other, then the corresponding unit cylinders are perpendicular to the plane of the centers of the balls (and therefore parallel to each other) and are tangent to each other.

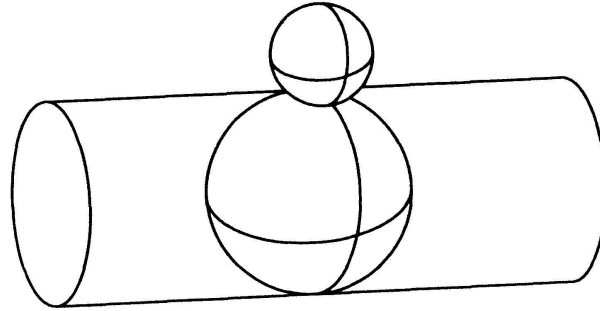

Figure 2.

2. Theorems

Theorem 1 (see also [4], p. 220). *For every packing of R^3 with unit cylinders there exists a ball of radius ϱ not overlapping with any of the cylinders.*

Proof. Start with a ball in the complement of all of the cylinders of the packing. Enlarge the size of the ball keeping the ball non-overlapping with the cylinders and moving the center of the ball if necessary. Observe that the enlargement process terminates only when the ball touches at least 3 cylinders. By the Main Lemma, at that moment the radius of the ball is already large enough.

Remark. A careful analysis of the procedure described in the above proof results in the following statement: Every point in the complement of all of the cylinders of the packing lies within $\sqrt{2/3}$ from the center of a ball of radius ϱ , non-overlapping with any of the cylinders. The number $\sqrt{2/3}$ is the smallest possible in this context, as it can be seen on the example of two tangent, perpendicular cylinders.

Theorem 2 (see also [4], p. 220). *Suppose P is a packing with unit cylinders such that every ball of radius $r > \varrho$ overlaps with one of the cylinders. Then all cylinders in P are parallel and each of them is tangent to six others.*

Proof. Let C be one of the cylinders of P and let A be a point on the surface of C but not on any of the other cylinders. Start with a small ball tangent to C at A and not overlapping with any of the cylinders and enlarge it, keeping it tangent to C and moving its center in a continuous fashion until the ball no longer can be enlarged (as in the proof of Theorem 1). At the final stage of the enlargement, the ball is tangent to C and to two other cylinders, and its radius is ϱ . By the Main Lemma, the three cylinders are parallel and tangent to each other. Since point A on the surface of C is arbitrary, this proves that C is touched by six other cylinders, parallel to each other and to C .

Main Theorem. *Suppose P is a packing with unit cylinders in which no two cylinders are parallel, and suppose that B_0 and B_1 are two balls of radius ϱ each and each non-overlapping with any of the cylinders of P . Then there exists a path $p: [0, 1] \rightarrow R^3$ such that $p(x)$ is the center of a ball B_x of radius ϱ , non-overlapping with any of the cylinders of P , for every $x \in [0, 1]$.*

Proof. Denote by C_i ($i = 1, 2, \dots$) the cylinders of P and let L_i be the axis of revolution of C_i . Let C_i^+ denote the *open* cylinder of radius $1 + \varrho = 2/\sqrt{3}$, coaxial with C_i , and let P^+ be the union of the cylinders C_i^+ .

Observe that a point X lies in the complement of P^+ if and only if the ball of radius ϱ centered at X does not overlap with any of the cylinders C_i . Thus, in order to prove the theorem it is enough to show that the complement of P^+ is pathwise connected. Considering the simple local structure of the complement of P^+ , all we need to show is its connectedness.

For each pair of intersecting cylinders C_i^+, C_j^+ ($i \neq j$), let B_{ij} denote the shortest segment connecting the skew lines L_i and L_j . Obviously, B_{ij} lies in C_i^+, C_j^+ . Denote the union of all lines L_i and all segments B_{ij} by G . Since G is a one-dimensional set in R^3 (in fact G is a locally finite graph), the complement of G is connected. Since no two cylinders C_i^+, C_j^+ are parallel, their intersection is always a bounded set. Topologically, the set is an open 3-cell, if not empty. Furthermore, by the Main Lemma, no three cylinders of P^+ intersect, thus no two of these 3-cells have a point in common. Therefore P^+ is a so-called *regular neighborhood* of G in R^3 (see [5], Ch. 3). In particular, G is a deformation retract of P^+ (in fact, a deformation retraction of P^+ onto G can be constructed explicitly, without reference) which implies that P^+ is homotopically equivalent to G . Since separation of R^3 is a homotopy invariant, P^+ does not separate R^3 .

Remark 1. The Main Theorem can be strengthened somewhat as follows. Instead of assuming that no two cylinders are parallel it is enough to assume that no two cylinders which are touched by the same ball of radius ϱ are parallel. The proof remains valid without a change.

Remark 2. The Main Theorem has another proof, a more elementary and constructive one, producing an algorithm for finding a path from B_0 to B_1 . However, this alternate proof requires more space as it involves many special cases. We chose the proof presented above because of its brevity.

Remark 3. In relation to the Main Theorem, one might consider the question of whether there exists a constant k such that the length of the path leading from B_0 to B_1 never exceeds k times the distance between the centers of the balls. It turns out that no such constant exists. This can be seen on the following example. Let C_i be the unit cylinder whose axis passes through the point $(2i, 0, 0)$, is perpendicular to the x -axis and forms an angle $\left(90 + \frac{1}{i}\right)^\circ$ with the $x y$ -plane ($i = 1, 2, 3, \dots$). The cylinders C_i form a "wall" between the points $P_i = (2i, 2, 0)$ and $Q_i = (2i, -2, 0)$, and the shortest path from P_i to Q_i along which a ball of radius ϱ can travel avoiding each C_i is of length increasing to infinity as i increases to infinity.

Remark 4. The Main Theorem and Remark 1 can be generalized to n dimensions ($n \geq 3$) by defining an n -dimensional cylinder as a set congruent to the Cartesian product of an $(n - 1)$ -dimensional ball and a line, and by replacing the number ϱ by $\varrho_n = \sqrt{\frac{2n-2}{n}} - 1$.

Moreover, this value of ϱ_n appears to be the greatest possible in the context of the generalized Main Theorem.

A. Bezdek, Cornell University, Ithaca and Hungarian Academy of Sciences, Budapest
W. Kuperberg, Auburn University, Auburn

REFERENCES

- 1 Bezdek A.: Remark on the closest packing of convex discs, *Studia Sci. Math. Hungar.* 15 (1980), 283–285.
- 2 Böröczky K.: Closest packing and loosest covering of the space with balls, *Studia Sci. Math. Hungar.* 21 (1986), 79–89.
- 3 Fejes Tóth L.: Remarks on the closest packing of convex discs, *Comment. Math. Helvet.* 53 (1978), 536–541.
- 4 Horváth J.: Über die Enge von Zylinderpackungen und die Lockerheit von Zylinderüberdeckungen im n -dimensionalen Euklidischen Raum. *Studia Sci. Math. Hungar.* 21 (1986), 219–255.
- 5 Rourke C. P., Sanderson B. J.: *Introduction to piecewise linear topology*, Springer Verlag 1982.

© 1991 Birkhäuser Verlag, Basel

0013-6018/91/02000-03 \$1.50 + 0.20/0

Konvergenz von Teilen der harmonischen Reihe

1. Einleitung

Es seien M die Menge der natürlichen Zahlen, in deren Dezimaldarstellung keine «9» auftritt, und P die Menge der Primzahlen. Dann ist wohlbekannt, daß (i) $\sum_{n \in M} n^{-1}$ konvergiert, wobei (ii) $\sum_{n \in P} n^{-1}$ divergiert. Ergebnis (i) geht wohl auf Kempner (1914) zurück; einen einfachen Beweis, der die Abschätzung $\sum_{n \in M} n^{-1} < 90$ liefert, findet man in Honsberger (1982), S. 89 ff. Irwin (1916) und Wadhwa (1975) geben untere und obere Schranken für die analoge Reihe an, die durch Weglassen aller eine «0» enthaltenden Terme entsteht. In dieser Arbeit wollen wir für eine ganze Klasse nach diesem Muster gebildeter Reihen eine einfache Abschätzung herleiten. Dieses Ergebnis werden wir dann anwenden, um zu zeigen, daß es für jedes $k \geq 0$ eine Primzahl gibt, deren Dezimaldarstellung eine gegebene Ziffer (etwa «9») mehr als k -mal enthält, und um eine obere Schranke für die kleinste derartige Primzahl zu gewinnen.

2. Teilreihen von $\sum n^{-1}$

Im folgenden seien eine natürliche Zahl $d \geq 2$, ein $j \in \{0, 1, \dots, d-1\}$ und eine ganze Zahl $k \geq 0$ fest gewählt. Für jedes $n \in \mathbb{N}$ gibt es eine eindeutige d -adische Darstellung $n = a_0 + a_1 d + a_2 d^2 + \dots$ mit $a_0, a_1, \dots \in \{0, 1, \dots, d-1\}$. Die Koeffizienten a_i nennen wir die Ziffern von n . Sei nun M die Menge aller natürlichen Zahlen, in deren d -adischer Entwicklung die Ziffer j höchstens k -mal auftritt.