

Zeitschrift: Helvetica Physica Acta
Band: 42 (1969)
Heft: 1

Artikel: Normal solutions of the linearized Boltzmann equation
Autor: Scharf, G.
DOI: <https://doi.org/10.5169/seals-114052>

Nutzungsbedingungen

Die ETH-Bibliothek ist die Anbieterin der digitalisierten Zeitschriften. Sie besitzt keine Urheberrechte an den Zeitschriften und ist nicht verantwortlich für deren Inhalte. Die Rechte liegen in der Regel bei den Herausgebern beziehungsweise den externen Rechteinhabern. [Siehe Rechtliche Hinweise.](#)

Conditions d'utilisation

L'ETH Library est le fournisseur des revues numérisées. Elle ne détient aucun droit d'auteur sur les revues et n'est pas responsable de leur contenu. En règle générale, les droits sont détenus par les éditeurs ou les détenteurs de droits externes. [Voir Informations légales.](#)

Terms of use

The ETH Library is the provider of the digitised journals. It does not own any copyrights to the journals and is not responsible for their content. The rights usually lie with the publishers or the external rights holders. [See Legal notice.](#)

Download PDF: 02.04.2025

ETH-Bibliothek Zürich, E-Periodica, <https://www.e-periodica.ch>

Normal Solutions of the Linearized Boltzmann Equation¹⁾

by **G. Scharf**

Institut für Theoretische Physik der Universität Zürich

(21. III. 68)

Summary. The problems of initial and boundary conditions in hydrodynamics are discussed on the basis of the linearized Boltzmann equation. Using the hydrodynamic approximation involving the normal solutions, the connection problem of relating the actual initial values of the hydrodynamic quantities to the initial values appropriate to the equations of fluid dynamics is solved. Explicit formulae correcting the initial layer are given in the Navier-Stokes approximation. The normal solutions are then applied to steady state problems of the Boltzmann equation. In this connection a useful method for treating boundary value problems is employed. Finally the nature of the hydrodynamic approximation is investigated. It is found that this approximation is correct in the two limiting cases, either (i) finite mean free path ε as $t \rightarrow \infty$, or (ii) finite time as $\varepsilon \rightarrow 0$. The approach to equilibrium or to a steady state is also considered.

I. Introduction

This paper continues the functional analytic discussion of the linearized Boltzmann equation given in [1]. Furthermore, it illustrates the general results with some explicit calculations concerning the problem of initial conditions in hydrodynamics and the boundary value problem for the Boltzmann equation.

The most familiar method for deriving the equations of fluid dynamics is that of using the Boltzmann equation. Since the hydrodynamic equations are partial differential equations in space and time, one needs initial and boundary conditions to define solutions. Usually these are set up by intuitively physical arguments. However, the consistent procedure would be to deduce them also from the Boltzmann equation. In doing so, it turns out that the actual boundary and initial values of the hydrodynamic quantities are not the correct ones to be used for the hydrodynamic equations. This is due to the appearance of the so-called initial and boundary layers [2]. Within these layers the fluid shows no hydrodynamic behaviour, and that leads to the problem of relating the actual initial and boundary values with the values seen by the hydrodynamic solution if the layers were absent.

As was already pointed out in [1], the first of these connection problems, namely the correction of the initial values, can be completely solved by means of the method of normal solutions. This method is described in the following section. In the third section the explicit calculation is presented and the connection formulae are given in the Navier-Stokes approximation. In the fourth section the normal solutions will be

¹⁾ Work supported by the Swiss National Foundation.

applied to steady state problems of the Boltzmann equation. For this purpose a method of treating boundary value problems will be given which may be of more general interest, in that it shows how the boundary value problem can be investigated if the problem in infinite space has been solved. The calculations are carried through for the two simplest problems: for Couette flow and for heat flow. In these cases we reach the limit of validity of the hydrodynamic approximation involving the normal solutions because the microscopic part of the general solution of the Boltzmann equation cannot be neglected within the boundary layer.

The last section is devoted to some basic questions concerning the nature of the hydrodynamic approximation. It will be shown that this approximation is correct in the two limiting cases, either (i) finite mean free path ε as $t \rightarrow \infty$ or (ii) finite time as $\varepsilon \rightarrow 0$. Moreover in the first case we show that the microscopic part decays exponentially with some microscopic relaxation time, in agreement with Onsager's assumption on the regression of fluctuations [6, 7]. This problem was left open in [1]. Finally the arguments are extended to arbitrary solutions of the Boltzmann equation, and it is proved that every solution of the Boltzmann equation in infinite space tends strongly to 0 as $t \rightarrow \infty$. This result is also sufficient to prove the approach to a steady state for the special class of boundary conditions considered in Section IV.

II. The Normal Solutions

We recall some of the general results of the discussion of the Boltzmann equation in [1]. The initial value problem for the linearized Boltzmann equation [1] (2)

$$\frac{\partial f}{\partial t} = -\mathbf{v} \frac{\partial f}{\partial \mathbf{x}} - I f \quad (1)$$

is solved by a contraction semigroup T^t in a Hilbert space $\mathcal{H} = L^2(\mathbf{R}^3) \otimes L^2_{\varphi_0}(\mathbf{R}^3)$ according to [1] (11)

$$f(t) = T^t f(0). \quad (2)$$

The scalar product in \mathcal{H} is defined by

$$(f, g)_{\mathbf{x}, \mathbf{v}} = \int \bar{f}(\mathbf{x}, \mathbf{v}) g(\mathbf{x}, \mathbf{v}) d^3x \varphi_0(\mathbf{v}) d^3v,$$

where $\varphi_0(v)$ is the space-independent Maxwell distribution. The (complex) Hilbert space $L^2_{\varphi_0}$ with respect to the velocity will be used simultaneously, the space coordinates being fixed. Therefore the different scalar products will be distinguished by indices.

If the collision operator I refers to a hard potential and the spatial Fourier transform $\hat{f}_0(\mathbf{k}, \mathbf{v})$ of the initial distribution $f(\mathbf{x}, \mathbf{v}, 0)$ satisfies

$$\hat{f}_0(\mathbf{k}, \mathbf{v}) = 0 \quad \text{for} \quad |\mathbf{k}| > \varkappa, \quad (3)$$

where \varkappa is some constant of the order of magnitude of the inverse mean free path, then the general solution (2) can be split into a hydrodynamic and a microscopic part

$$f(t) = T_2^t f(0) + T_3^t f(0) = T^t f_2 + T^t f_3. \quad (4)$$

The condition (3) implies $f(\mathbf{x}, \mathbf{v}, 0)$ to be analytic in \mathbf{x} and rapidly decreasing as $|\mathbf{x}| \rightarrow \infty$.

For the hydrodynamic part $T^t f_2$, we have the following expansion formula [1] (46)

$$T^t f_2 = f_2(t) = \frac{1}{(2\pi)^{3/2}} \sum_{j=1}^5 \int f^j(\mathbf{k}) g_j(\mathbf{k}, \mathbf{v}) e^{i\mathbf{k}\cdot\mathbf{x} - i\omega_j(k)t} d^3k \quad (5)$$

where

$$\begin{aligned} f^j(\mathbf{k}) &= \frac{1}{(2\pi)^{3/2}} \int e^{-i\mathbf{k}\cdot\mathbf{x}} h^j(\mathbf{k}, \mathbf{v}) f_0(\mathbf{x}, \mathbf{v}) \varphi_0(v) d^3x d^3v \\ &= \frac{1}{(2\pi)^{3/2}} \langle e^{i\mathbf{k}\cdot\mathbf{x}} h_j, f_0 \rangle_{x,v}. \end{aligned} \quad (6)$$

Here the $g_j(\mathbf{k}, \mathbf{v})$ are the normal solutions, $-i\omega_j(k)$ the corresponding eigenvalues and $h_j(\mathbf{k}, \mathbf{v})$ the corresponding biorthogonal system, i. e.

$$(g_j, h_l)_v = \delta_{jl}.$$

These quantities can be calculated explicitly by the Chapman-Enskog procedure or by perturbation theory. In the latter method, which is due to McLENNAN [4, 5], one finds $-i\omega_j$ and g_j as the eigenvalues and eigenfunctions of the operator $\hat{B}_k = -i\mathbf{k}\cdot\mathbf{v} - I$ in $L^2_{\varphi_0}$ by treating $-i\mathbf{k}\cdot\mathbf{v}$ as a perturbation of the form $-ik\mathbf{e}^3\cdot\mathbf{v}$, where $\mathbf{e}^3 = \mathbf{k}/k$ is the unit vector in the direction of \mathbf{k} and $-ik$ is the perturbing parameter. It is necessary to use this form because the standard perturbation theorems refer only to one perturbing parameter (in fact one sees in (8) that the results are not analytic in \mathbf{k}).

We state the eigenfunctions and eigenvalues up to first and second order in k respectively. This is the Navier-Stokes approximation, as will be seen in the next section.

$$-i\omega_{1,2}(k) = -\eta k^2 \quad -i\omega_3(k) = -\frac{2}{5}\lambda k^2 \quad -i\omega_{4,5}(k) = \mp ikc - \Gamma k^2 \quad (7)$$

$$g_1(\mathbf{k}, \mathbf{v}) = \mathbf{v} \cdot \mathbf{e}^1 - i \sum_{ij} T_{ij} k_i e_j^1$$

$$g_2(\mathbf{k}, \mathbf{v}) = \mathbf{v} \cdot \mathbf{e}^2 - i \sum_{ij} T_{ij} k_i e_j^2$$

$$g_3(\mathbf{k}, \mathbf{v}) = \sqrt{\frac{2}{5}} \left[u - \frac{5}{2} + i \frac{2}{5} \lambda \mathbf{v} \cdot \mathbf{k} - i \mathbf{S} \cdot \mathbf{k} \right]$$

$$\begin{aligned} g_{4,5}(\mathbf{k}, \mathbf{v}) &= \sqrt{\frac{2}{15}} \left[u - i \left(\frac{1}{2} \eta - \frac{1}{10} \lambda \right) \mathbf{v} \cdot \mathbf{k} - i \mathbf{S} \cdot \mathbf{k} \right] \\ &\pm \frac{1}{\sqrt{2}} \left[\mathbf{v} \cdot \mathbf{e}^3 + i \frac{2}{5} \lambda k + ik \left(\frac{2}{15} \eta - \frac{14}{75} \lambda \right) u - i \sum_{ij} T_{ij} k_i e_j^3 \right] \end{aligned} \quad (8)$$

$$k = |\mathbf{k}| \quad u = \frac{1}{2} v^2 \quad c = \sqrt{\frac{5}{3}} \quad \Gamma = \frac{2}{3} \left(\eta + \frac{1}{5} \lambda \right) \quad \mathbf{e}^3 = \frac{\mathbf{k}}{k}.$$

Here we have used dimensionless quantities as in [1], and furthermore have taken units such that the particle mass and the equilibrium values are $m = n_0 = T_0 = 1$. $\mathbf{e}^1, \mathbf{e}^2, \mathbf{e}^3$ are unit vectors, with \mathbf{e}^3 parallel and $\mathbf{e}^1, \mathbf{e}^2$ perpendicular to \mathbf{k} . The quantities \mathbf{S} and T_{ij} are the solutions of the integral equations

$$I \mathbf{S} = \left(u - \frac{5}{2}\right) \mathbf{v} \quad I T_{ij} = v_i v_j - \frac{1}{3} \delta_{ij} v^2$$

with

$$(\mathbf{S}, w_l)_v = 0 \quad (T_{ij}, w_l)_v = 0 \quad l = 1, \dots, 5,$$

where $w_l = 1, \mathbf{v}, 1/2 v^2$ are the summational invariants. The thermal conductivity λ and the viscosity η are determined by

$$\begin{aligned} \left(\left(u - \frac{5}{2}\right) v_i, S_j\right)_v &= \lambda \delta_{ij} \\ \left(v_i v_j - \frac{1}{3} \delta_{ij} v^2, T_{lm}\right)_v &= \eta \left(\delta_{il} \delta_{jm} + \delta_{im} \delta_{jl} - \frac{2}{3} \delta_{ij} \delta_{lm}\right). \end{aligned} \quad (9)$$

The eigenfunctions (8) satisfy the relation

$$(g_j, g_l)_v = \delta_{jl} + O(k^2),$$

hence, in this order of k the biorthogonal system $\{h_j\}$ is identical with the $\{g_j\}$ system.

The general structure of the normal solutions and the eigenvalues in higher order can be described by means of simple symmetry properties. Let J be the complex conjugation operator

$$J: f(\mathbf{v}) \rightsquigarrow \bar{f}(\mathbf{v})$$

and P the parity operator in $L_{\varphi_0}^2$

$$P: f(\mathbf{v}) \rightsquigarrow f(-\mathbf{v}).$$

Then $PJ = JP$ is an antilinear conjugation in $L_{\varphi_0}^2$ which commutes with \hat{B}_k . Therefore, if $g_j(\mathbf{k}, \mathbf{v})$ is an eigenfunction of \hat{B}_k with eigenvalue $-i\omega_j(k)$, then $\bar{g}_j(\mathbf{k}, -\mathbf{v})$ is an eigenfunction with eigenvalue $-i\overline{\omega_j(k)}$. We see from (8) that the normal solutions transform under PJ according to

$$PJ g_1 = -g_1 \quad PJ g_2 = -g_2 \quad PJ g_3 = g_3 \quad PJ g_4 = g_5 \quad PJ g_5 = g_4.$$

Since g_1, g_2, g_3 are only multiplied by a factor, $-i\omega_1, -i\omega_2, -i\omega_3$ must be real but $-i\omega_4 = i\bar{\omega}_5$. From the invariance of \hat{B}_k under rotations of \mathbf{v} around the \mathbf{k} -axis it follows that the degeneracy, $-i\omega_1 = -i\omega_2$, occurs in arbitrary order, and that the normal solutions transform under a rotation R_α around \mathbf{k} as follows

$$\begin{aligned} R_\alpha g_1 &= g_1 \cos \alpha + g_2 \sin \alpha \\ R_\alpha g_2 &= -g_1 \sin \alpha + g_1 \cos \alpha \quad R_\alpha g_l = g_l, \quad l = 3, 4, 5. \end{aligned} \quad (10)$$

Finally \hat{B}_k is invariant under simultaneous rotation of \mathbf{v} and \mathbf{k} indicating that the eigenvalues and normal solutions are scalars with respect to these rotations. Summing up, we arrive at the following general expressions

$$\begin{aligned}
 -i\omega_l(k) &= \alpha_{l,2} k^2 + \alpha_{l,4} k^4 + \dots \quad l = 1, 2, 3 \\
 -i\omega_4(k) &= i\bar{\omega}_5(k) = i\alpha_{4,1} k + \alpha_{4,2} k^2 \\
 &\quad + i\alpha_{4,3} k^3 + \alpha_{4,4} k^4 + \dots \quad \alpha_{l,j} \text{ real constants,} \\
 g_l &= n_{l,0} + i \sum_j k_j m_{l,1}^j + \sum_{i_1 i_2} k_{j_1} k_{j_2} n_{l,2}^{i_1 i_2} + \dots \quad l = 1, 2 \\
 g_3 &= m_{3,0} + i \sum_j k_j n_{3,1}^j + \sum_{i_1 i_2} k_{j_1} k_{j_2} m_{3,2}^{i_1 i_2} + \dots \\
 g_{4,5} &= m_{4,0} + i \sum_j k_j n_{4,1}^j + \sum_{i_1 i_2} k_{j_1} k_{j_2} m_{4,2}^{i_1 i_2} + \dots \\
 &\quad \pm \left[n_{4,0} + i \sum_j k_j m_{4,1}^j + \sum_{i_1 i_2} k_{j_1} k_{j_2} n_{4,2}^{i_1 i_2} + \dots \right]
 \end{aligned}$$

where the m 's and n 's are real functions of \mathbf{v} and \mathbf{k} , even and odd in \mathbf{v} respectively. They are homogeneous functions of degree 0 in \mathbf{k} , which behave as tensors under simultaneous rotation of \mathbf{v} and \mathbf{k} and have further transformation properties given by (10). The biorthogonal functions h_j have the same general form.

III. Initial Conditions for Hydrodynamic Equations

In what follows we shall use the hydrodynamic approximation, that means we approximate the general solution (4) of the Boltzmann equation by its hydrodynamic part (5). This approximation leads to the hydrodynamic description of the fluid. It will be shown in the last section that this approximation is correct in the two limiting cases, either (i) finite mean free path ε as $t \rightarrow \infty$, or (ii) finite time as $\varepsilon \rightarrow 0$. Considering the problem of the initial conditions for the hydrodynamic equations we have in mind the first of these limiting cases. After an aging period, where the microscopic part is decreased, one is left with the hydrodynamic part alone which leads to hydrodynamic behaviour. This agrees with Onsager's assumption on the regression of fluctuations [6, 7].

The problem now is to calculate the hydrodynamic variables corresponding to the hydrodynamic part of the general given initial distribution. The hydrodynamic variables are

$$n' = n_0 + n \quad T' = T_0 + T \quad \mathbf{w}' = \mathbf{w}_0 + \mathbf{w}$$

where their derivations n , T , \mathbf{w} from the equilibrium values

$$n_0 = T_0 = 1 \quad \mathbf{w}_0 = 0$$

are obtained from an arbitrary distribution function $f(\mathbf{x}, \mathbf{v}, t)$ by

$$n(\mathbf{x}) = (1, f)_v \quad \mathbf{w}(\mathbf{x}) = (\mathbf{v}, f)_v \quad \frac{3}{2} T(\mathbf{x}) = \left(u - \frac{3}{2}, f \right)_v. \quad (11)$$

The stress tensor τ_{ij} and the heat flow vector \mathbf{q} are

$$\tau_{ij}(\mathbf{x}) = \left(v_i v_j - \frac{1}{3} \delta_{ij} v^2, f \right)_v \quad \mathbf{q}(\mathbf{x}) = \left(\left(u - \frac{5}{2} \right) \mathbf{v}, f \right)_v. \quad (12)$$

It follows from the construction in [1], and will be verified explicitly below, that the hydrodynamic variables, calculated up to a certain order in k with the hydrodynamic part alone, satisfy hydrodynamic equations corresponding to this order. Therefore the correct initial values $n_1(\mathbf{x})$, $\mathbf{w}_1(\mathbf{x})$, $T_1(\mathbf{x})$ for these equations are obtained by forming the moments of $f_2(0)$ in (5). In this way only the contributions from the long fived part of the given general initial distribution f are calculated.

It is convenient to calculate the Fourier transformed variables

$$\begin{aligned} \hat{n}_1(\mathbf{k}) &= \frac{1}{(2\pi)^{3/2}} \langle e^{i\mathbf{k}\cdot\mathbf{x}} 1, f_2(0) \rangle_{x,v} = \sum_{j=1}^5 f^j(\mathbf{k}) (1, g_j)_v \\ \hat{\mathbf{w}}_1(\mathbf{k}) &= \frac{1}{(2\pi)^{3/2}} \langle e^{i\mathbf{k}\cdot\mathbf{x}} \mathbf{v}, f_2(0) \rangle_{x,v} = \sum_{j=1}^5 f^j(\mathbf{k}) (\mathbf{v}, g_j)_v \\ \frac{3}{2} \hat{T}_1(\mathbf{k}) &= \frac{1}{(2\pi)^{3/2}} \langle e^{i\mathbf{k}\cdot\mathbf{x}} \left(u - \frac{3}{2} \right), f_2(0) \rangle_{x,v} = \sum_{j=1}^5 f^j(\mathbf{k}) \left(\left(u - \frac{3}{2} \right), g_j \right)_v. \end{aligned} \quad (13)$$

The expression (6) contain the actual (uncorrected) hydrodynamic initial values

$$\begin{aligned} f^1(\mathbf{k}) &= \hat{\mathbf{w}}(\mathbf{k}) \cdot \mathbf{e}^1 - i \sum_{ij} (T_{ij} k_i, f)_v e_j^1 \\ f^2(\mathbf{k}) &= \hat{\mathbf{w}} \cdot \mathbf{e}^2 - i \sum_{ij} (T_{ij} k_i, f)_v e_j^2 \\ f^3(\mathbf{k}) &= \sqrt{\frac{2}{5}} \left[\frac{3}{2} \hat{T} - \hat{n} + i \frac{2}{5} \lambda \hat{\mathbf{w}} \cdot \mathbf{k} - i (\mathbf{S}, f)_v \cdot \mathbf{k} \right] \\ f^{4,5}(\mathbf{k}) &= \sqrt{\frac{2}{15}} \left[\frac{3}{2} \hat{T} + \frac{3}{2} \hat{n} - i \left(\frac{1}{2} \eta - \frac{1}{10} \lambda \right) \hat{\mathbf{w}} \cdot \mathbf{k} - i (\mathbf{S}, f)_v \cdot \mathbf{k} \right] \\ &\quad \pm \frac{1}{\sqrt{2}} \left[\hat{\mathbf{w}} \cdot \mathbf{e}^3 + i k \frac{2}{5} \lambda \hat{n} + i k \left(\frac{2}{15} \eta - \frac{14}{75} \lambda \right) \left(\frac{3}{2} \hat{T} + \frac{3}{2} \hat{n} \right) \right. \\ &\quad \left. - i \sum_{ij} (T_{ij} k_i, f)_v \frac{k_j}{k} \right]. \end{aligned}$$

Inserting this in (13), taking terms up to $0(k)$ only, and inverting the Fourier transformation we obtain the corrected variables

$$\begin{aligned} n_1(\mathbf{x}) &= n(\mathbf{x}) \\ w_{1,l}(\mathbf{x}) &= w_l(\mathbf{x}) - \sum_j \frac{\partial}{\partial x_j} (T_{jl}, f)_v \\ T_1(\mathbf{x}) &= T(\mathbf{x}) - \frac{2}{3} \sum_j \frac{\partial}{\partial x_j} (S_j, f)_v. \end{aligned} \quad (14)$$

Proceeding in exactly the same way with the moments (12) instead of the summational invariants we obtain with (9) the Navier-Stokes relations

$$\begin{aligned}\tau_{ij} &= -\eta \left[\frac{\partial w_j}{\partial x_i} + \frac{\partial w_i}{\partial x_j} - \frac{2}{3} \delta_{ij} \operatorname{div} \mathbf{w} \right] \\ \mathbf{q} &= -\lambda \nabla T.\end{aligned}\quad (15)$$

This shows explicitly that (7), (8) and the initial values (14) are associated with the Navier-Stokes approximation. Indeed, inserting (15) in the conservation laws one gets the Navier-Stokes equations.

The corrections to the initial values in (14) depend on the whole initial Boltzmann distribution function and on the collision operator through the quantities T_{jl} and S_j . For practical purposes it would be desirable to express the corrections in terms of a few easily measurable quantities and the transport coefficients. This can be done by approximating $f(\mathbf{x}, \mathbf{v})$ in (14) by the first few terms of the Hermite expansion

$$\begin{aligned}f(\mathbf{x}, \mathbf{v}) &= u(\mathbf{x}) 1 + \mathbf{w}(\mathbf{x}) \mathbf{v} + T(\mathbf{x}) \left(u - \frac{3}{2} \right) \\ &+ \frac{1}{2} \sum_{ij} \tau_{ij}(\mathbf{x}) \left(v_i v_j - \frac{1}{3} \delta_{ij} v^2 \right) + \frac{2}{5} \sum_i q_i(\mathbf{x}) \left(u - \frac{5}{2} \right) v_i + \dots\end{aligned}$$

Then using (9) we obtain

$$\begin{aligned}w_{1,l}(\mathbf{x}) &= w_l(\mathbf{x}) - \eta \sum_j \frac{\partial \tau_{jl}(\mathbf{x})}{x_j} \\ T_1(\mathbf{x}) &= T(\mathbf{x}) - \frac{4}{15} \lambda \operatorname{div} \mathbf{q}(\mathbf{x}).\end{aligned}\quad (16)$$

Hence, the corrections to the initial values in the Navier-Stokes equations depend on the derivatives of the fluxes. The result (16) has also been obtained by GRAD [3] in the special case of Maxwellian molecules.

IV. Steady State Problems

At first a few words must be said about the treatment of boundary value problems.

The problem is to find a solution $f(\mathbf{x}, \mathbf{v}, t)$ of the Boltzmann equation (1) which assumes given values $f_0(\mathbf{x}, \mathbf{v})$ at $t = 0$ and fulfills boundary conditions for \mathbf{x} at the boundary of some finite region Ω . Outside Ω we are free to define f in any way to obtain a function in $\mathcal{H} = L^2(\mathbb{R}^3) \otimes L^2_{\varphi_0}(\mathbb{R}^3)$. In general for any sensible definition, f is no longer a solution of (1) outside Ω because there must exist sources of energy and momentum in order to preserve the boundary conditions. Therefore we consider the Boltzmann equation with an inhomogeneity $h(\mathbf{x}, \mathbf{v})$ which is only different from 0 outside the system Ω . $h(\mathbf{x}, \mathbf{v})$ may be regarded physically as a source term

$$\frac{\partial f}{\partial t} = -\mathbf{v} \frac{\partial f}{\partial \mathbf{x}} - I f + h = B f + h \quad (17)$$

$$h(\mathbf{x}, \mathbf{v}) = 0 \quad \text{for } \mathbf{x} \in \Omega. \quad (18)$$

As before B denotes the Boltzmann operator for the infinite space which we are able to handle. Clearly with fixed time independent source functions $h(\mathbf{x}, \mathbf{v})$ only a special class of boundary conditions can be described. However concerning steady state problems, this is just an interesting class.

Equation (17) can be directly integrated by means of the semigroup T^t referring to the infinite space [1]. Instead of the general result

$$f(t) = T^t f_0 + \int_0^t T^{t-s} h ds$$

we use the following expression

$$f(t) = T^t f_0 - B^{-1} h + T^t B^{-1} h \quad h \in D(B^{-1}) \quad (19)$$

which makes sense if B is invertible and h is in the domain of B^{-1} . This form has the advantage that the approach to a steady state may easily be discussed in (19). We shall prove in the next section that the semigroup T^t corresponding to the Boltzmann operator in the infinite space tends strongly to 0

$$T^t f \rightarrow 0 \quad \forall f \in \mathcal{H} \quad \text{as } t \rightarrow \infty. \quad (20)$$

Then it follows from (19) that

$$f(t) \rightarrow f_\infty = -B^{-1} h \quad \text{strongly as } t \rightarrow \infty. \quad (21)$$

$f_\infty(\mathbf{x}, \mathbf{v})$ is the steady state. This is of particular interest, because it determines the right choice of the source function $h(\mathbf{x}, \mathbf{v})$, and if it is known the solution of the initial value problem can be calculated from (19).

Again we want to use the hydrodynamic approximation, which now reads as follows

$$f_\infty(\mathbf{x}, \mathbf{v}) = -\frac{1}{(2\pi)^3} \sum_{j=1}^5 \frac{\langle e^{i\mathbf{k}\cdot\mathbf{x}} h_j, h \rangle_{\mathbf{x}, \mathbf{v}}}{-i\omega_j(\mathbf{k})} g_j(\mathbf{k}, \mathbf{v}) e^{i\mathbf{k}\cdot\mathbf{x}} d^3k. \quad (22)$$

As will be shown in Section V.2 this hydrodynamic part approaches the exact solution in the limit of vanishing mean free path. In this limit the integral $\int d^3k$ in (22) can be extended over the whole of \mathbf{R}^3 . In order to see explicitly the dependence on the mean free path we introduce a parameter ε of the order of magnitude of the mean free path in the Boltzmann equation

$$\frac{\partial \hat{f}}{\partial t} = \left(-i\mathbf{k} \cdot \mathbf{v} - \frac{1}{\varepsilon} I \right) \hat{f} = \hat{B}_\varepsilon \hat{f},$$

as is done in the Hilbert theory. The eigenvalues $-i\omega_\varepsilon(\mathbf{k})$ and the eigenfunctions $g_\varepsilon(\mathbf{k}, \mathbf{v})$ of \hat{B}_ε can be found from the corresponding ones of \hat{B}_k by

$$\begin{aligned} -i\omega_\varepsilon(\mathbf{k}) &= -\frac{i}{\varepsilon} \omega(\varepsilon \mathbf{k}) \\ g_\varepsilon(\mathbf{k}, \mathbf{v}) &= g(\varepsilon \mathbf{k}, \mathbf{v}). \end{aligned} \quad (23)$$

The question that remains is the choice of the source term h according to the condition (18) so that f_∞ satisfies the boundary conditions. We answer this question for the two simplest problems: for Couette flow (pure shear flow) between parallel plates and for heat flow. We find that a very natural choice of $h(\mathbf{x}, \mathbf{v})$ is possible, indicating that the method should also work in more complicated geometric situations²⁾. However, to get the quantitative structures of the boundary layers, the inverse B^{-1} must be treated more accurately than by the hydrodynamic approximation (22) as will be illustrated by the following calculations.

(i) *Couette flow*. Let us consider two parallel plates of distance $2d$ moving with velocities u_1 and $-u_1$ in the y -direction. Then all quantities are space dependent only along the x -direction so that the problem is essentially one-dimensional. We choose

$$h(x, \mathbf{v}) = a v_y [\delta(x-d) - \delta(x+d)] \quad (24)$$

where $\delta(x)$ is the one-dimensional δ -function. Physically speaking Equation (24) represents point sources of momentum at the positions of the walls. The factor a determines the rate of momentum production per unit volume and unit time, which we assume to be constant. Clearly this h is not in $D(B_\epsilon^{-1})$, or even in the Hilbert space $\mathcal{H} = L^2(\mathbf{R}^1) \otimes L^2_{\varphi_0}(\mathbf{R}^3)$. However, we calculate formally with this singular h at first, because this is very simple, and give rigorous justification later. Formula (22) can be evaluated in arbitrary order of k in the following way: we insert the expansions of g_j and h_j in a certain order of k , say k^n , in the numerator and take only terms up to $O(k^n)$. The eigenvalues $-i\omega_j$ in the denominator are calculated up to $O(k^{n+1})$, so that we have a pure fraction and therefore the Fourier integral is convergent as $k \rightarrow \infty$.

With (7), (8) and (23) the eigenvalues and the normal solutions take the form

$$\begin{aligned} -i\omega_{1,\epsilon}(k) &= -i\omega_{2,\epsilon}(k) = -\eta\epsilon k^2 \\ -i\omega_{3,\epsilon}(k) &= -\frac{2}{5}\lambda\epsilon k^2 \\ -i\omega_{4,5,\epsilon}(k) &= \mp ic|k| - \Gamma\epsilon k^2 \\ g_{1,\epsilon}(k, \mathbf{v}) &= \operatorname{sgn} k (v_y - i\epsilon k T_{xy}) \\ g_{2,\epsilon}(k, \mathbf{v}) &= \operatorname{sgn} k (v_z - i\epsilon k T_{xz}) \\ g_{3,\epsilon}(k, \mathbf{v}) &= \sqrt{\frac{2}{5}} \left[u - \frac{5}{2} + \frac{2}{5}\lambda\epsilon ikv_x - \epsilon ik S_x \right] \\ g_{4,5,\epsilon}(k, \mathbf{v}) &= \sqrt{\frac{2}{15}} \left[u - \left(\frac{1}{2}\eta - \frac{1}{10}\lambda \right) \epsilon ikv_x - \epsilon ik S_x \right] \\ &\quad \pm \frac{1}{\sqrt{2}} \left[\operatorname{sgn} k v_x + \frac{2}{5}\lambda\epsilon i|k| \right] \\ &\quad + \left(\frac{2}{15}\eta - \frac{14}{15}\lambda \right) \epsilon i|k| u - \epsilon i|k| T_{xx} \end{aligned} \quad (25)$$

$$k = k_x, \quad -\infty < k < +\infty.$$

²⁾ A treatment of Stokes flow past a sphere will appear in The Physics of Fluids.

Since these are also the h_j 's in this order of k , we see that with (24) only one mode contributes in (22), namely the term $j = 1$, giving

$$\begin{aligned} f_\infty(x, \mathbf{v}) &= -\frac{1}{2\pi} \frac{2ia}{\eta\varepsilon} P \int_{-\infty}^{+\infty} dk \frac{\sin kd}{k^2} (h_1, v_y)_v g_1 e^{ikx} \\ &= -\frac{ia}{\pi\eta\varepsilon} P \int_{-\infty}^{+\infty} dk \left[\frac{\sin kd}{k^2} e^{ikx} v_y - \varepsilon i \frac{\sin kd}{k} e^{ikx} T_{xy} \right] \\ &= \frac{2a}{\pi\eta\varepsilon} \frac{\pi}{2} (x v_y - T_{xy}) \quad |x| < d. \end{aligned}$$

Here the principal value integral must be taken, due to singular choice of h . Setting the constant a equal to $a = \eta\varepsilon u_1/d$ we arrive at

$$\begin{aligned} f_\infty(x, \mathbf{v}) &= \frac{u_1}{d} x v_y - \frac{u_1}{d} \varepsilon T_{xy} \quad |x| < d \\ &= \pm u_1 v_y \mp \frac{1}{2} \varepsilon T_{xy} \quad x = \pm d \\ &= \pm u_1 v_y \quad x \gtrless \pm d. \end{aligned} \tag{26}$$

From (26) we find the linear velocity dependence and the constant stress between the plates

$$\tau_{xy} = -\eta\varepsilon \frac{u_1}{d} = -\eta' \frac{u_1}{d}$$

in perfect agreement with the Navier-Stokes equations. There is no boundary layer in this approximation.

In order to justify the above formal calculation we choose instead of (24) a source function $h(x, \mathbf{v})$ which is an element of the Hilbert space \mathcal{H} , is 0 for $|x| < d$ and belongs to the domain $D(B^{-1})$. The latter means that its Fourier transform $\hat{h}(k, \mathbf{v})$ vanishes as, or stronger than, k^2 for $|k| \rightarrow 0$. These requirements are satisfied by the following function

$$\begin{aligned} h(x, \mathbf{v}) &= a v_y h_1(x) \\ h_1(x) &= -h_1(-x) = \begin{cases} \frac{1}{\delta} & d \leq x \leq d + \delta \\ -A e^{-\alpha(x-d-\delta)} & x > d + \delta \\ 0 & x < d \end{cases} \end{aligned} \tag{27}$$

where

$$\frac{A}{\alpha^2} = d \quad \alpha = \frac{\delta}{2d(d+\delta)} \quad a = \eta\varepsilon \frac{u_1}{d}. \tag{28}$$

It might be noted that this source function converges to (24) if $\delta \rightarrow 0$ in the sense of distributions. Now the calculation is carried through without any trouble and the result is

$$f_\infty(x, \mathbf{v}) = \left(\frac{u_1}{d} x v_y - \frac{u_1}{d} \varepsilon T_{xy} \right) (1 - \alpha d).$$

Replacing the factor a in (28) by $a_1 = a/1 - \alpha d$, this agrees exactly with (26). We could now forget the above singular procedure, but the later is much simpler in computation. This is even more striking in the case of the heat flow problem.

(ii) *Heat flow.* For heat flow between parallel plates of distance $2d$ we choose the following singular source function

$$h(x, \mathbf{v}) = a \left(u - \frac{3}{2} \right) [\delta(x-d) - \delta(x+d)],$$

which represents constant heat production at the positions of the walls. Now, three modes contribute, namely the terms in g_3, g_4, g_5 . These yield the following expression

$$\begin{aligned} f_\infty = & -\frac{ia}{\pi} P \int_{-\infty}^{+\infty} dk e^{ikx} \sin kd \left\{ \frac{3}{2\lambda} \left[\frac{1}{\varepsilon k^2} \left(u - \frac{5}{2} \right) + \frac{i}{k} \left(\frac{2}{5} \lambda v_x - S_x \right) \right. \right. \\ & + u b_1 \sqrt{\frac{2}{15}} \frac{2\Gamma\varepsilon}{c^2 + \Gamma^2 \varepsilon^2 k^2} + v_x \frac{b_1}{\sqrt{2}} \frac{2i}{c} \left(\frac{\Gamma^2 \varepsilon^2 k}{c^2 + \Gamma^2 \varepsilon^2 k^2} - \frac{1}{k} \right) \\ & - (\eta_1 v_x + S_x) \sqrt{\frac{2}{15}} b_1 \frac{2i\Gamma\varepsilon^2 k}{c^2 + \Gamma^2 \varepsilon^2 k^2} + \left(\frac{2}{5} \lambda + \eta_2 u - T_{xx} \right) \frac{b_1}{\sqrt{2}} \frac{2c\varepsilon}{c^2 + \Gamma^2 \varepsilon^2 k^2} \\ & \left. \left. + u c_1 \sqrt{\frac{2}{15}} \frac{2c\varepsilon}{c^2 + \Gamma^2 \varepsilon^2 k^2} + v_x \frac{c_1}{\sqrt{2}} \frac{2i\Gamma\varepsilon^2 k}{c^2 + \Gamma^2 \varepsilon^2 k^2} \right] \right\} \end{aligned}$$

with

$$\begin{aligned} b_1 = \frac{3}{2} \sqrt{\frac{2}{15}} \quad c_1 = \frac{1}{\sqrt{2}} \left(\frac{1}{5} \eta - \frac{7}{25} \lambda \right) \quad \Gamma = \frac{2}{3} \eta + \frac{2}{15} \lambda \\ \eta_1 = \frac{1}{2} \eta - \frac{1}{10} \lambda \quad \eta_2 = \frac{2}{15} \eta - \frac{14}{75} \lambda \quad c = \sqrt{\frac{5}{3}}. \end{aligned}$$

Here we have to take only terms up to $O(\varepsilon)$ because the contributions from higher orders and from the microscopic part are also $O(\varepsilon)$, as is pointed out below. With $a = 2/3 \lambda \varepsilon T_1/d$ we get the final result

$$\begin{aligned} f_\infty(x, \mathbf{v}) = & \frac{T_1}{d} \left[x \left(u - \frac{5}{2} \right) - \varepsilon S_x \right. \\ & + u \frac{16}{45} \left(\eta - \frac{3}{5} \lambda \right) \frac{\lambda}{\Gamma^2} \frac{\Gamma\varepsilon}{c} e^{-(c/\Gamma\varepsilon)d} \operatorname{sh} \frac{c}{\Gamma\varepsilon} x \\ & + \frac{4}{15} \frac{\lambda^2}{\Gamma^2} \frac{\Gamma\varepsilon}{c} e^{-(c/\Gamma\varepsilon)d} \operatorname{sh} \frac{c}{\Gamma\varepsilon} x \\ & \left. - T_{xx} \frac{2}{3} \frac{\lambda}{\Gamma^2} \frac{\Gamma\varepsilon}{c} e^{-(c/\Gamma\varepsilon)d} \operatorname{sh} \frac{c}{\Gamma\varepsilon} x \right]. \end{aligned}$$

This solution shows a boundary layer of the order of magnitude and of the thickness of the mean free path. The temperature is

$$T(x) = \frac{T_1}{d} \left[x + \frac{16}{45} \left(\eta - \frac{3}{5} \lambda \right) \frac{\lambda}{\Gamma^2} \frac{\Gamma\varepsilon}{c} e^{-(c/\Gamma\varepsilon)d} \operatorname{sh} \frac{c}{\Gamma\varepsilon} x \right]. \quad (29)$$

The heat flow

$$q_x(x) = \left(\left(u - \frac{5}{2} \right) v_x, f_\infty \right)_v = - \frac{T_1}{d} \varepsilon \lambda = - \frac{T_1}{d} \lambda'$$

is constant, as it must be because of the conservation of energy. Since we have introduced the parameter ε in the collision operator, the thermal conductivity is now $\lambda' = \varepsilon \lambda$ instead of λ . Considering the other hydrodynamic quantities, we see that the velocity is 0 as it must be because of particle conservation, but there is a stress in x -direction

$$t_{xx} = (v_x^2, f_\infty)_v = - \frac{T_1}{d} \frac{4}{15} \frac{\lambda^2}{T^2} \frac{\Gamma \varepsilon}{c} e^{-(c/\Gamma \varepsilon)d} \operatorname{sh} \frac{c}{\Gamma \varepsilon} x.$$

Since this stress is not constant, the conservation of momentum seems to be violated, showing that there must be other contributions of the same order of magnitude.

Looking at the general structure in higher order we see that this is indeed the case. It is convenient to decompose the fractional function of k occurring in (22) into partial fractions. A typical term, arising from a simple zero, $(k_1 + i k_2)/\varepsilon$, of the denominator has the form

$$\frac{A}{k - (k_1 + i k_2)/\varepsilon}$$

where A and k_1, k_2 are complex constants of $O(\varepsilon^0)$. Such a term yields exponential contributions to the boundary layer

$$\sim \varepsilon e^{1/\varepsilon(-|k_2| + i k_1)(d \pm x)}, \quad k_2 \geq 0.$$

Furthermore, the contribution from the microscopic part is of the same order of magnitude (see Section V.2), so this should also be taken into account. This shows clearly the limitation of a boundary layer theory which is based on the Navier-Stokes equations only.

V. The Nature of the Hydrodynamic Approximation

1. The Microscopic Part as $t \rightarrow \infty$

Let us return to the decomposition (4) of the semigroup solution in the Fourier transformed form

$$\hat{T}^t \hat{f} = \hat{T}_2^t \hat{f} + \hat{T}_3^t \hat{f}.$$

Our object is to prove that the microscopic part $\hat{T}_3^t \hat{f}$ is rapidly decreasing as $t \rightarrow \infty$.

As was pointed out in [1], the infinitesimal generator \hat{A}_3 of \hat{T}_3^t is the restriction of the Fourier transformed Boltzmann operator

$$\hat{B} = -i \mathbf{k} \cdot \mathbf{v} - \nu(v) + K \tag{30}$$

to the hydrodynamic subspace $\hat{\mathcal{H}}_3 = (1 - J) E_\times \hat{\mathcal{H}}$ of the basic Hilbert space $\hat{\mathcal{H}} = L^2(\mathbf{R}^3) \otimes L^2_{\varphi_0}(\mathbf{R}^3)$. Furthermore, it was found that the spectrum of \hat{A}_3 lies in the half plane $\operatorname{Re} \lambda \leq -\gamma < 0$. However, since \hat{A}_3 is not self-adjoint, this alone does not

imply the desired result. An additional property of \hat{A}_3 must be used, namely its sectorial property.

The semigroup \hat{T}_3^t can be expressed in terms of the resolvent $R(\lambda, \hat{A}_3)$ as an inverted Laplace integral ([8], p. 349)

$$\hat{T}_3^t \hat{f} = s\text{-}\lim_{\omega \rightarrow \infty} \frac{1}{2\pi i} \int_{a-i\omega}^{a+i\omega} e^{\lambda t} R(\lambda, \hat{A}_3) \hat{f} d\lambda \quad \hat{f} \in D(\hat{A}_3) \quad a > 0. \quad (31)$$

Since $R(\lambda, \hat{A}_3)$ is holomorphic for $Re \lambda > -\gamma$, the integral on the right hand side of (29) can be transformed by Cauchy's theorem

$$\int_{a-i\omega}^{a+i\omega} = \int_{a-i\omega}^{-\gamma'-i\omega} + \int_{-\gamma'-i\omega}^{-\gamma'+i\omega} + \int_{-\gamma'+i\omega}^{a+i\omega} \quad -\gamma < -\gamma' < 0 \quad (32)$$

(see figure). Here we show that the first and the third integral tend to 0 as $\omega \rightarrow \infty$.

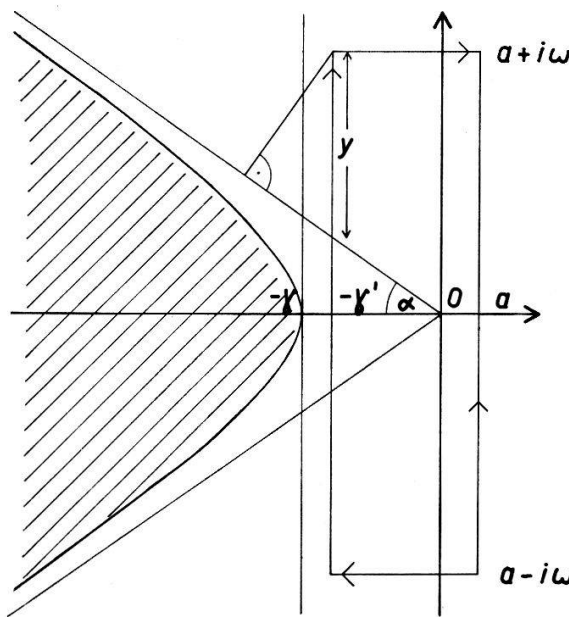

Spectrum $\sigma(A_3)$ corresponding to the microscopic part together with the path of integration.

For this purpose we must estimate the resolvent. It follows from

$$(\lambda - \hat{B}) \hat{f} = (\lambda + i \mathbf{k} \cdot \mathbf{v} + \nu(v)) \hat{f} + K \hat{f}$$

that

$$\begin{aligned} \|(\lambda - \hat{B}) \hat{f}\| &\geq \|(\lambda + i \mathbf{k} \cdot \mathbf{v} + \nu(v)) \hat{f}\| - \|K \hat{f}\| \\ &> \left[\min_{|\mathbf{k}| \leq \kappa, v} |\lambda + i \mathbf{k} \cdot \mathbf{v} + \nu(v)| - \|K\| \right] \|\hat{f}\| \stackrel{\text{def}}{=} C_\lambda \|\hat{f}\| \end{aligned}$$

and

$$R(\lambda, \hat{A}_3) \leq \frac{1}{C_\lambda}. \quad (33)$$

Since the collision frequency $\nu(v)$ is proportional to v for large v , the values of $i \mathbf{k} \cdot \mathbf{v} + \nu(v)$ with large imaginary part lie within a sector (see figure). Then we have for large $|\operatorname{Im} \lambda|$

$$\min |\lambda + i \mathbf{k} \cdot \mathbf{v} + \nu(v)| > y \cos \alpha = (|\operatorname{Im} \lambda| - \gamma' \operatorname{tg} \alpha) \cos \alpha$$

where

$$\alpha < \frac{\pi}{2} \text{ for } \kappa < \infty.$$

Thus

$$C_\lambda > |\operatorname{Im} \lambda| \cos \alpha - \gamma' \sin \alpha - \|K\| \geq \frac{|\operatorname{Im} \lambda|}{1/\cos \alpha + \delta} \stackrel{\text{def}}{=} \frac{|\operatorname{Im} \lambda|}{D}$$

with some finite arbitrarily small δ , merely if

$$|\operatorname{Im} \lambda| (\gamma' \sin \alpha + \|K\|) \left(\frac{1}{\delta \cos^2 \alpha} + \frac{1}{\cos \alpha} \right) \stackrel{\text{def}}{=} L. \quad (34)$$

Let

$$l = \max_{|\operatorname{Im} \lambda| \leq L} \|R(\lambda, \hat{A}_3)\| \quad (35)$$

$Re \lambda$ varying in some finite interval, then it follows from (33), (34), (35)

$$\|R(\lambda, \hat{A}_3)\| \leq \frac{D}{D/l + |\operatorname{Im} \lambda|} \quad \forall \operatorname{Im} \lambda, \quad (36)$$

and such an estimate holds uniformly for $Re \lambda$ in some finite interval.

As a first consequence of (36) we see that in (31) only the second integral of (32) contributes, that is

$$\begin{aligned} \hat{T}_3^t f &= s\text{-}\lim_{\omega \rightarrow \infty} \frac{1}{2\pi i} \int_{-\gamma' - i\omega}^{\gamma' + i\omega} e^{\lambda t} R(\lambda, \hat{A}_3) \hat{f} d\lambda \\ &= e^{-\gamma t} \lim_{\omega \rightarrow \infty} \frac{1}{2\pi i} \int_{-\omega}^{+\omega} e^{(\gamma - \gamma' - i\lambda')t} R(-\gamma' + i\lambda') \hat{f} d\lambda'. \end{aligned} \quad (37)$$

In the remaining integral we use the resolvent equation

$$R(-\gamma' + i\lambda') = R(\gamma - \gamma' + i\lambda') + \gamma R(-\gamma' + i\lambda') R(\gamma - \gamma' + i\lambda').$$

The contribution from the first term on the right is readily estimated

$$\left\| \lim_{\omega \rightarrow \infty} \frac{1}{2\pi i} \int_{-\omega}^{+\omega} e^{(\gamma - \gamma' + i\lambda')t} R(\gamma - \gamma' + i\lambda') \hat{f} d\lambda' \right\| = \|\hat{T}_3^t \hat{f}\| \leq \|\hat{f}\|.$$

In the contribution of the second term we again use (36):

$$\begin{aligned} &\left\| \frac{\gamma}{2\pi i} \int_{-\omega}^{+\omega} e^{(\gamma - \gamma' + i\lambda')t} R(-\gamma' + i\lambda') R(\gamma - \gamma' + i\lambda') \hat{f} d\lambda' \right\| \\ &\leq \frac{\gamma}{2\pi} e^{(\gamma - \gamma')t} D^2 \int_{-\omega}^{+\omega} \frac{d\lambda'}{(D/l + |\lambda'|)^2} \|\hat{f}\| \leq \gamma l D e^{(\gamma - \gamma')t} \|\hat{f}\|. \end{aligned}$$

Finally we get from (37)

$$\|\hat{T}_3^t \hat{f}\| \leq e^{-\nu t} (1 + \gamma l D e^{(\nu-\nu')t}) \|f\| < e^{-\nu' t} (1 + \gamma l D) \|\hat{f}\|, \quad (38)$$

showing indeed that the microscopic part decreases exponentially in time.

2. The Microscopic Part as the Mean Free Path $\rightarrow 0$

In order to discuss this limit it is convenient to again introduce into the Boltzmann equation the parameter ε , of the order of magnitude of the mean free path

$$\frac{\partial \hat{f}}{\partial t} = \left(-i \mathbf{k} \cdot \mathbf{v} - \frac{1}{\varepsilon} I \right) \hat{f}. \quad (39)$$

Let $\hat{f}(\mathbf{k}, \mathbf{v}, t, \varepsilon)$ be the solution of (39) subject to prescribed initial values. By a transformation of variables.

$$t^* = \frac{t}{\varepsilon} \quad \mathbf{k}^* = \mathbf{k} \cdot \varepsilon \quad f^*(\mathbf{k}^*, \mathbf{v}, t^*) = \hat{f}(\mathbf{k}, \mathbf{v}, t, \varepsilon). \quad (40)$$

We return to the problem already discussed

$$\begin{aligned} \frac{\partial f^*}{\partial t^*} &= (-i \mathbf{k}^* \cdot \mathbf{v} - I) f^* \\ f^*(\mathbf{k}^*, \mathbf{v}, 0) &= 0 \quad \text{for } |\mathbf{k}^*| > \kappa. \end{aligned} \quad (41)$$

With (38) we can estimate the microscopic part of $f^*(\mathbf{k}^*, \mathbf{v}, t)$

$$\|f_3^*(\mathbf{k}^*, \mathbf{v}, t)\|_{\mathbf{k}^*, \mathbf{v}} \leq e^{-\nu' t^*} (1 + \gamma l D) \|\hat{f}(\mathbf{k}^*, \mathbf{v}, 0)\|_{\mathbf{k}^*, \mathbf{v}}.$$

This reads in terms of the ordinary variables (40)

$$\|\hat{T}_3^t(\varepsilon) \hat{f}(\mathbf{k}, \mathbf{v}, 0, \varepsilon)\|_{\mathbf{k}, \mathbf{v}} \leq e^{-\nu'(t/\varepsilon)} (1 + \gamma l D) \|\hat{f}(\mathbf{k}, \mathbf{v}, 0, \varepsilon)\|_{\mathbf{k}, \mathbf{v}} \quad (42)$$

showing that the microscopic part decreases rapidly as $\varepsilon \rightarrow 0$ for all finite t . The restriction (41) on the initial distribution now requires

$$\hat{f}(\mathbf{k}, \mathbf{v}, 0, \varepsilon) = 0 \quad \text{for } |\mathbf{k}| > \frac{\kappa}{\varepsilon}$$

which means in the limit $\varepsilon \rightarrow 0$ that the initial distribution must only have a compact support in \mathbf{k} -space. Since this is a dense set in the Hilbert space \mathcal{H} , and the semigroup $\hat{T}_3^t(\varepsilon)$ is uniformly bounded $\|\hat{T}_3^t(\varepsilon)\| \leq 1$, we conclude that every solution of (39) converges to its hydrodynamic part if $\varepsilon \rightarrow 0$. In calculating the latter, the integrals $\int d^3k$ in (5) and (22) over the whole of \mathbf{R}^3 are strongly converging.

Using (42) in the expression

$$\hat{R}_3(\varepsilon, \lambda) = \int_0^\infty e^{-\lambda t} \hat{T}_3^t(\varepsilon) dt$$

for the resolvent we get an estimate for the inverse \hat{A}_3^{-1} of the Boltzmann operator in the microscopic subspace \mathcal{H}_3 :

$$\|\hat{A}_3^{-1} \hat{f}\| \leq \|\hat{f}\| (1 + \gamma l D) \int_0^\infty e^{-(\gamma'/\varepsilon)t} dt = \frac{1 + \gamma l D}{\gamma'} \varepsilon \|\hat{f}\|.$$

This shows that in the limit $\varepsilon \rightarrow 0$ the microscopic part does not contribute to the steady state solution of the boundary value problem according to (21), (22). But it does influence the boundary layer which is also $O(\varepsilon)$, supposing a source function h with $\|h\| = O(\varepsilon^0)$.

3. The Hydrodynamic Part as $t \rightarrow \infty$

In the passage of time the hydrodynamic part also decreases to the equilibrium state which is 0 in the whole space problem, but it decreases slowly.

Let $f \in \mathcal{H}_3$ be sufficiently regular, so that the integral in the expansion formula (5) is absolutely convergent for $t = 0$. Then

$$T_2^t f = \frac{1}{(2\pi)^{3/2}} \sum_j \int_{|\mathbf{k}| \leq \varkappa} f_j(\mathbf{k}) g_j(\mathbf{k}, \mathbf{v}) e^{i\mathbf{k} \cdot \mathbf{x} - i\omega_j^1(\mathbf{k})t - \omega_j^2(\mathbf{k})t} d^3k$$

where

$$-i\omega_j(\mathbf{k}) = -i\omega_j^1(\mathbf{k}) - \omega_j^2(\mathbf{k}).$$

Now

$$|T_2^t f| \leq \frac{1}{(2\pi)^{3/2}} \sum_j \int_{|\mathbf{k}| \leq \varkappa} |f_j(\mathbf{k})| |g_j(\mathbf{k}, \mathbf{v})| e^{-\omega_j^2(\mathbf{k})t} d^3k, \quad (43)$$

but $\omega_j^2(\mathbf{k}) \geq 0$, and = 0 only on a set of measure 0 in k -space, because of the analyticity in k . Hence it follows from the Lebesgue convergence theorem that

$$|T_2^t f| \rightarrow 0 \quad \text{as} \quad t \rightarrow \infty, \quad \forall \mathbf{v}, \text{ uniformly in } \mathbf{x},$$

and in the same way

$$\|T_2^t f\|_{\mathbf{x}, \mathbf{v}} \rightarrow 0.$$

4. Arbitrary Solutions

For the previous arguments the restriction (3)

$$f_0(\mathbf{k}, \mathbf{v}) = 0 \quad |\mathbf{k}| > \varkappa \quad (44)$$

with some fixed constant \varkappa , defined by the collision operator I , was essential. We now remove this restriction and wish to prove that every solution of the Boltzmann equation (1) tends to 0 as $t \rightarrow \infty$ (30). This follows from an extension of the previous arguments.

As in [1] the unitary mapping of the basic Hilbert space \mathcal{H} into the direct integral of Hilbert spaces $L_{\varphi_0}^2$

$$\begin{aligned} \mathcal{H} &\rightarrow \int \oplus L_{\varphi_0}^2(\mathbf{k}) d^3k \\ B &\rightarrow \int \oplus \hat{B}_k d^3k, \end{aligned}$$

by means of spatial Fourier transformation, reduces the problem to the discussion of the operator

$$\hat{B}_k = -i \mathbf{k} \cdot \mathbf{v} - \nu(v) + K, \quad \mathbf{k} \text{ fixed,}$$

in $L^2_{\varphi_0}$. Since K is compact, we know the essential spectrum $\sigma_e(\hat{B}_k)$ of \hat{B}_k

$$\sigma_e(\hat{B}_k) = \sigma_e(-i \mathbf{k} \cdot \mathbf{v} - \nu(v)) \stackrel{\text{def}}{=} \sigma_e = \{-i \mathbf{k} \cdot \mathbf{v} - \nu(v) \mid k \text{ fixed}\}.$$

Because the complement of σ_e is connected, the essential spectrum can be understood here in the strong sense of Browder ([10] theorem 2.6). This means that a point ω in the spectrum $\sigma(\hat{B}_k)$ but $\notin \sigma_e$ must be an isolated eigenvalue of \hat{B}_k with finite algebraic multiplicity. We then have a direct decomposition of \hat{B}_k

$$\hat{B}_k = \hat{B}_k^2 \oplus \hat{B}_{\omega_1}^3 \oplus \hat{B}_{\omega_2}^3 \oplus \dots$$

which is analogous to the previous one. The operator \hat{B}_k^2 is regular outside σ_e and the $\hat{B}_{\omega_j}^3$ are operators in finite dimensional spaces. The structure of the $\hat{B}_{\omega_j}^3$ is well known,

$$\hat{B}_{\omega_j}^3 = \omega_j P_{\omega_j} + D_{\omega_j},$$

with a finite dimensional projector P_{ω_j} and a nilpotent operator D_{ω_j} . However, \hat{B}_k is J -self-adjoint with respect to the complex conjugation J [1]. Consequently the same is true for all $\hat{B}_{\omega_j}^3$, and therefore the nilpotent operators D_{ω_j} must be 0. Hence the $\hat{B}_{\omega_j}^3$ are diagonalizable and the corresponding part of the semigroup can be expanded as the hydronic part in [1] (46)

$$T_3^t f = \frac{1}{(2\pi)^{3/2}} \sum_{j=1}^{\infty} \int \sum_{l=1}^{l_j(\mathbf{k})} f_{j,l}(\mathbf{k}) g_{j,l}(\mathbf{k}, \mathbf{v}) e^{i \mathbf{k} \cdot \mathbf{x} - i \omega_j(\mathbf{k}) t} d^3 k \tag{45}$$

We integrate over the whole of k -space, setting the eigenfunctions $g_{j,l}(\mathbf{k}) = 0$ if there is no isolated eigenvalue $\omega_j(\mathbf{k})$ of \hat{B}_k .

It will now be shown that an isolated eigenvalue $\omega_j(k_0)$ of \hat{B}_{k_0} varies analytically in some neighbourhood of \mathbf{k}_0 . This follows from the fact that \hat{B}_k is a holomorphic family of type B in $L^2_{\varphi_2}$ ([9], p. 395). To see this we need only verify that \hat{B}_{k_0} is sectorial and closed and that the quadratic form of the disturbing operator

$$\hat{B}_k - \hat{B}_{k_0} = -i (\mathbf{k} - \mathbf{k}_0) \cdot \mathbf{v} \stackrel{\text{def}}{=} \mu \frac{(\mathbf{k} - \mathbf{k}_0) \cdot \mathbf{v}}{|\mathbf{k} - \mathbf{k}_0|}$$

is relatively bounded ([9], p. 398).

Now

$$\begin{aligned} |\operatorname{Im} (f, \hat{B}_{k_0} f)_v| &\leq |\mathbf{k}_0| (f, v f)_v \leq |\mathbf{k}_0| \left(f, \frac{\nu(v)}{b} f \right)_v \\ &\leq \frac{|\mathbf{k}_0|}{b} (f, (I + K) f)_v \leq \frac{|\mathbf{k}_0|}{b} [\|K\| \|f\|_v^2 + (f, I f)_v] \end{aligned} \tag{46}$$

because $\nu(v) > b v$ for some $b > 0$. Since I is the real part of \hat{B}_{k_0} , equation (46) shows that \hat{B}_{k_0} is sectorial. On the other hand

$$\left| \left(f, \frac{(\mathbf{k} - \mathbf{k}_0) \cdot \mathbf{v}}{|\mathbf{k} - \mathbf{k}_0|} f \right)_v \right| \leq (f, \nu f)_v \leq \frac{\|K\|}{b} \|f\|_v^2 + \frac{1}{b} (f, I f)_v,$$

hence, the perturbation is bounded relative to $\operatorname{Re} \hat{B}_{k_0}$ and therefore \hat{B}_k is holomorphic for $|\mu| = |\mathbf{k} - \mathbf{k}_0| < b$.

We now have all the results necessary to prove that every solution of the Boltzmann equation (1) decreases to 0 as $t \rightarrow \infty$. Let the initial distribution $\hat{f}_0(\mathbf{k}, \mathbf{v})$ have compact support in \mathbf{k} -space (44), but with an *arbitrary* finite constant \varkappa . Then the 'generalized microscopic part'

$$T_2^t f = \frac{1}{(2\pi)^{3/2}} \int (e^{t\hat{B}_k^2} \hat{f}_0(\mathbf{k}, \mathbf{v})) e^{i\mathbf{k}\cdot\mathbf{x}} d^3k$$

settles down as $t \rightarrow \infty$ because of the arguments in No. 1 of this section. The 'generalized hydrodynamic part' (45) goes to 0 because the integrand in (45) goes to 0 almost everywhere as $t \rightarrow \infty$ just as in No. 3. Since the functions \hat{f}_0 with compact support in \mathbf{k} form a dense set in $\hat{\mathcal{H}} = L^2(\mathbb{R}^3) \otimes L_{\varphi_0}^2(\mathbb{R}^3)$, we conclude, by means of the uniform boundedness of the semigroup $\|T^t\| \leq 1$, that every solution of the Boltzmann equation decreases to 0 as $t \rightarrow \infty$. Then the approach to a steady state follows for the special class of boundary conditions considered in Section IV.

References

- [1] G. SCHARF, *Helv. phys. Acta* 40, 929 (1967).
- [2] H. GRAD, *Handbuch der Physik*, Bd. XII, Berlin (1958).
- [3] H. GRAD, *Physics Fluids* 6, 147 (1963).
- [4] J. A. MCLENNAN, *Physics Fluids* 8, 1580 (1965).
- [5] J. A. MCLENNAN, *Physics Fluids* 9, 1581 (1966).
- [6] J. A. MCLENNAN, *Helv. phys. Acta* 40, 645 (1967).
- [7] L. ONSAGER, *Phys. Rev.* 37, 405 (1931).
- [8] E. HILLE, R. S. PHILLIPS, *Functional Analysis and Semigroups*, Amer. Math. Soc. Coll. Publ. (1957).
- [9] T. KATO, *Perturbation Theory for Linear Operators*, Berlin (1966).
- [10] M. SCHECHTER, *J. Math. Anal. appl.* 13, 205 (1966).