

Zeitschrift: The Swiss observer : the journal of the Federation of Swiss Societies in the UK

Herausgeber: Federation of Swiss Societies in the United Kingdom

Band: - (1971)

Heft: 1625

Rubrik: Swiss events

Nutzungsbedingungen

Die ETH-Bibliothek ist die Anbieterin der digitalisierten Zeitschriften. Sie besitzt keine Urheberrechte an den Zeitschriften und ist nicht verantwortlich für deren Inhalte. Die Rechte liegen in der Regel bei den Herausgebern beziehungsweise den externen Rechteinhabern. [Siehe Rechtliche Hinweise.](#)

Conditions d'utilisation

L'ETH Library est le fournisseur des revues numérisées. Elle ne détient aucun droit d'auteur sur les revues et n'est pas responsable de leur contenu. En règle générale, les droits sont détenus par les éditeurs ou les détenteurs de droits externes. [Voir Informations légales.](#)

Terms of use

The ETH Library is the provider of the digitised journals. It does not own any copyrights to the journals and is not responsible for their content. The rights usually lie with the publishers or the external rights holders. [See Legal notice.](#)

Download PDF: 01.04.2025

ETH-Bibliothek Zürich, E-Periodica, <https://www.e-periodica.ch>

The Balaxert Shopping Centre is similar. The promoters, Migros and Grand Passage SA, have attempted to lend it the same atmosphere as the main shopping streets of Geneva. The sales surface is as large as a square field 160 yards wide. The car park is twice as large. There are further vast spaces on the mezzanine for strolls and terraces helping to mingle pleasantness with usefulness. Thirty-seven important businesses have opened shop there and employ about 600 people.

The next development will be the staff-less shop. *Carrefour* has pioneered in bringing goods straight from lorries on to the shelves and a Migros super-

market in Zurich has no cashier. Two ideas have already been experimented and will be applied sooner or later. One is for each shopper to have an account with a supermarket, to record his purchases on its computer and settle the account monthly by credit transfer. The second is for the shopper to inform a computer of the goods required by using a keyboard and waiting for them to be conveyed automatically.

If these ideas are worthwhile then there is no doubt that Switzerland's powerful chain stores will be among the first to make use of them.

(PMB)

town's incineration factory to an open-air dump at Illiswil, near Wohlen, 10 kilometres east of the city. Following investigations by the University of Berne, it was proved that petrol residues, oils and acids included in the dump at Illiswil had been responsible for the total pollution of the small lake of Wohlen.

The management of the incinerating plant explained that these mishaps were due to its annual closing down during May made necessary by the revision of its boilers.

Only nuclear power stations to be built in the future

Professor Urs Hochstrasser, Director of the Division for Research and Commerce at the Federal Department of the Interior, disclosed that practically all the power stations to be built in Switzerland will be nuclear power stations. At the end of next year the three power stations erected at Beznau and Mühleberg will be supplying a fifth of the country's electric requirements.

The gases produced by these nuclear plants are released in the atmosphere after an appropriate treatment and their radioactivity is less than a hundredth of natural radioactivity. Liquid effluents are equally processed in a special plant and rejected in rivers in accordance with official prescriptions. The harm on a person drinking nothing but river water has been measured as less than one per cent of the natural sources of pollution.

The cooling of nuclear power stations has however presented more difficulties. New federal directives put a limit to the tolerable heating of rivers in the cooling process of nuclear power stations and prescribe the erection of cooling towers. However, their construction no longer depends on the Confederation but on the Communes and can therefore be delayed by local opposition. This is the case of the power station due to be built at Kaiseaugst. Its completion will be entirely dependent on the assent of the communal electorate.

The smell of a fertiliser factory

In the small village of Saillon (Valais) a Lausanne firm set up an ultra modern plant to convert chicken dung into fertilisers. It cost two million francs to install and had a processing capacity of four tons of manure an hour. Very soon, however, the operations of the factory attracted the complaints of neighbouring farmers unhappy about the dust and the smell produced.

Many hundreds of thousands of francs were spent in improving equipment within the plant, but the smell

SWISS EVENTS

DIPLOMACY

Rapprochement with France

Mr. Maurice Schumann went to Berne on an official visit on September 15th and 17th before moving on to Zurich to attend the memorial ceremony to Churchill's famous 1946 speech. He met the Federal Council and engaged in a 10-hour conference session with the Swiss Government.

He was put in the picture of the Swiss position regarding her association with the Common Market and reminded that her neutrality placed certain bounds on the extent of her European involvement. The subjects raised in the Report by the Commission on neutral candidates were debated, in particular the technical problems related to the watch industry. There were disagreements on agriculture, Mr. Schumann requiring of the Swiss that they should buy more EEC foodstuffs.

Another item which the French were particularly keen to press forward was the eventual acquisition of 90 French Mirages of the "Milan" type in replacement of the outdated Venoms of the Air Force. The experts of the Military Department are known to favour the American "Corsair" ground assault jet fighter but have not yet made their final decision. It is reckoned in Berne that the "Milan" is now more likely than ever before to be adopted.

There is no doubt that a defence contract of this magnitude would serve to strengthen Franco-Swiss relations. It would certainly encourage the French to support Swiss demands regarding association to the EEC. Traditionally France's attitude was diffident towards the concept of permanent neutrality and she was not willing to compromise with Switzerland in the field of common agricultural policy.

However, her attitude has tended

to change and the French Government is well aware of Switzerland's financial importance, enhanced by the recent monetary crisis. A rapprochement with a central small European state would actually be in keeping with traditional Gaullist policy.

A new diplomatic offensive?

There is some evidence that Berne is intending to increase its diplomatic commitments in the world. The possibility of a Swiss participation in a future conference on European security is being given serious consideration. Switzerland has recently passed agreements with Rumania and Yugoslavia and will be shortly opening negotiations with Poland. Many commentators feel that it is time for Switzerland to belong to the International Monetary Fund and become a full-fledged member of the Group of Ten. Both steps being amply justified by Switzerland's financial weight in the world.

Besides the indications that things may start moving faster on the Swiss diplomatic front, the position taken up by Finland, a neutral country, on the recognition of East Germany has been given full notice in Berne and may be taken as an example.

ENVIRONMENT

Dustmen's "scandal" in Berne

Scandal was the word used by Bernese conservationists to describe the revelations of a radio reporter on the handling of the town's refuse. As this happened less than two months after a serious case of pollution in the Aar, their feelings were still highly sensitised.

It appeared that about 40 lorries carried refuse every day from the

still persisted and induced the principal plaintiff to declare that, even for a million francs of damage, he would no longer endure the smell. It was forcing him to close all the windows of his farm and poisoned his very existence.

The Commune eventually had the factory closed down for a week, pending a decision on possible court action. The Manager convened the Press and showed them his installations. "The people here knew very well that we weren't building a perfume factory", he said.

MODERN LIVING

Rent-payers revolt in Lausanne

The tenants of the 476-apartment estate of Pont-des-Sauges in Lausanne constituted an Assembly to make a united stand against unjustified rent increase by the owners and threats of expulsion. Last July they had marched through the town to press their demands and obtained the support of the Municipality. So far, the real-estate company concerned has rejected all their demands and negotiations are deadlocked.

The Great Council of Vaud has voted for new provisions in favour of rent-payers during an extraordinary session in mid-September. Representatives decided that pre-lease deposits handed over to estate agencies should be transferred within 10 days to the Cantonal Bank. This money will in future be withdrawn only on presentation of the double signature of lessor and lessee. These measures are intended to force landlords or estate agencies to justify any withholding of the deposits received from tenants.

New employment contract

The Swiss Code of Obligations, a legal charter containing the rules of conduct and exchange in a number of domains of commerce and industry, was given a revised chapter on the work contract. The new provisions came into force on 25th June this year. The rules of the Code of Obligations relating to the relations between employer and employee were first written down in 1911. But with the development of industry and the emergence of new industrial legislation, it became necessary to recapitulate the rulings of various new provinces of law, including the results of jurisprudence, into the Code of Obligations. The chapter on the working contract therefore gleans elements from related fields of legislation in order to offer a concise code of practise.

The new working contract, contrarily to the old one, does not make a distinction between "employé" and

"ouvrier". They are all "travailleurs".

If a contract has not been signed for a specified period, then it cannot be terminated without giving the person concerned at least a month's notice if he has been employed less than a year, at least two month's notice if the employment has lasted between a year and ten years, and at least three month's notice for over ten years employment.

The employer cannot terminate a work contract while his employee is performing military service or civil protection duties, as well as during the four weeks preceeding or following these terms of service if they have lasted for more than 12 days. This holds true during the four weeks of incapacity resulting from a labour accident not of the employee's fault. The period is extended to two months on the second year of employment. A female employee may not be given notice during the last eight weeks of pregnancy. An employee who takes up engagement abroad at the demand of the federal authorities may not have his work contract terminated during the first four weeks of service.

Other aspects of the new work contract refer to redundancy indemnities. This can be pre-arranged with the employer. If nothing has been determined the legislator has provided for indemnities in a number of cases. But in no event should this indemnity amount to more than eight months pay.

There is an important exception. It is that a person already covered against unemployment by some kind of insurance should not receive redundancy payment if the amount supplied by his cover is higher than that payment. If an employee is prevented from working for reasons beyond his control he is entitled to his pay during the first three weeks of incapacity when he has been employed more than three months. After the first year, this period of support may be extended on an "equitable basis".

The new contract allows the monthly payment of workers, subject to a collective agreement, by contrast to the traditional fortnightly payment of blue-collars.

TV programme disaster

French-speaking television was making a programme on Zurich as one of a series on Swiss cities. The programme was monitored from Geneva, whose studios were linked by a multiplex system to a meeting of the Vorort in a Zurich hotel, a TV reporter interviewing young dissenters at the Café Odeon and a fellow reporter in the Neumarkt Theatre.

The show was taken live and entirely unedited. As the debates and arguments between the President of

the Vorort and dissenting students were turning in circle the programme leader switched the scene to the "Odeon". There the situation was hardly more promising. The reporter was surrounded by a crowd of hippies eager for a romp. The time to spot a film on the Zurich Lindenhof Bunker and the crowd has swollen and become really threatening. The interviewing reporter did his best to keep things under control but his voice had inflexions betraying his worry.

The hippies pressing around him soon shouted anti-bourgeois slogans into his microphone. This failed demonstration of programme management at least gave viewers an image of the live problems of youth and Zurich. The programme leader switched to his last hope, an improvised performance by the actors of the "free" theatre at Neumarkt. Hardly had the masqueraded artists begun their act when a citizen of the Bunker sprang on the stage and firmly obstructed the camera's view. There was nothing the unfortunate reporter in charge could do. Back at the Geneva studio the programme leader precipitously curtailed the programme—and the lovely and usually voluble speaker announced the interruption with a rather shaken voice.

SPORTS

The 1974 Federal Shoot may take place at Fribourg

The Fribourg region has been more or less designated for the 1974 Federal shooting contest. The Cantonal Rifle Association firmly decided to favour this choice of venue on the condition however that it would lead to the construction of a permanent range. Such a range has been missing in Fribourg for about ten years.

A project for building a modern shooting range at Courtaney met with stiff opposition, not least from the residents of the Commune. An alternative solution could possibly be considered at Barberèche, but many people think that it is already too late to start making plans to be materialised by 1974. The Communal Council of Fribourg is bent on the matter and hopes that a solution will be found before long. If the town cannot guarantee that the necessary installations will be ready for the 1974 Federal Shoot, then other towns, notably Lucerne and Chur will be on the ranks.

BEHAVIOUR

Death of "Father" Stocker

Father Stocker, the main "Demon Hunter of Ringwil" died in an Old People's Home in Singen, Germany,

your home your office your factory

Sulzer's international experience solves heating problems in Britain

Sulzer's services range from industrial heating and ventilating contracts to a unique thermostatic radiator valve for use in domestic central heating systems. This valve, which is helping British families to get more economy and comfort from their central heating, is called Temset. Set it to the temperature you want — and from then on it keeps the room at that level of heat. Temset even makes adjustments to compensate for the number of people in the room and changes in the weather.

Sulzer Bros./London/Ltd., Bainbridge House, Bainbridge Street, London W.C.1.

SULZER

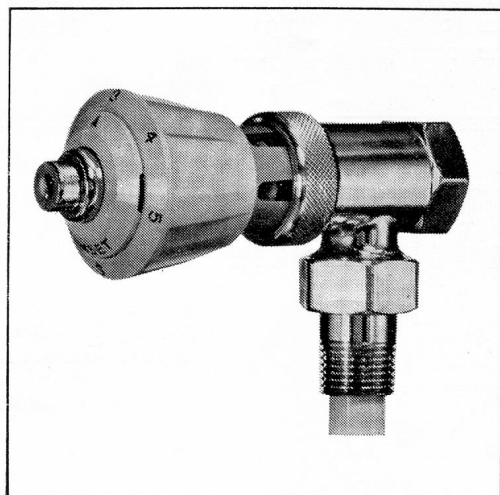
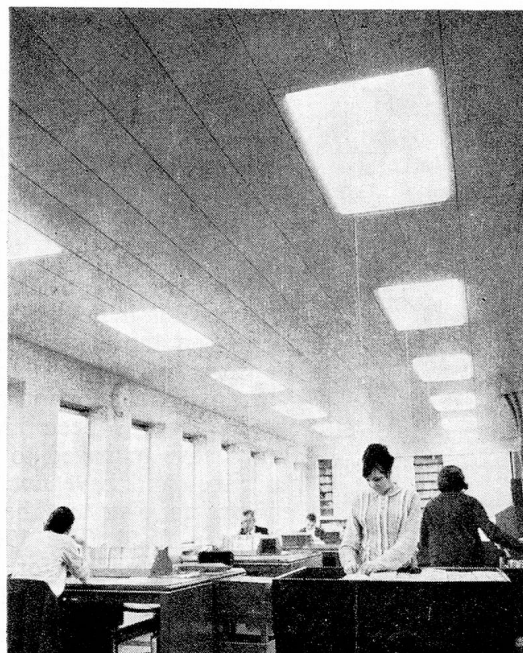

TEMSET

on 4th September. He was 64 and had been set free from a Zurich jail in October 1970 in consideration of his declining health following a decision by the public authorities of Zurich. In February 1969 the Zurich Assises had sentenced him to ten years imprisonment after having found him guilty with Magdalena Kohler and three other members of a Sect which he had animated of the death of Bernadette Hasler. The unfortunate 17-year-old girl had been so cruelly flagellated by the defendants in the course of an exercise in exorcism that she died of a blood clot.

Biological milk before the Federal Court

The Federal court has been seized with a rather unusual case. A farmer from Boudry (Ne) would not follow the rules imposed on Switzerland's 100,000 milk farmers and would not sell his milk through recognised and obligatory channels. Instead he sold his production at prices higher than the official norm to private individuals. The Legislator has provided for the possibility of selling milk privately when production conforms to a "special milk" label. But only about ten milk farmers in Switzerland take advantage of this provision.

Mr. Ducommun's milk did not conform to this specification—which did not deter him from labelling his milk as "biological" and enjoying considerable commercial success in his canton. The unshakeable belief that unpasteurised milk was safer kept him going. The conviction that the struggle against pollution should begin at the stomach level, probably abetted by his wish to be well known, prompted Mr. Ducommun in breaking the law.

The local milkman took exception to his withholding of milk deliveries and complained to the Communal Council. But the Commune could in no way stop Mr. Ducommun and appealed to the Canton. A trial at Cantonal level left him undaunted and the matter had to be raised up to the Federal level.

BUSINESS

A bank in five controlled from abroad

The Annual Report of the Swiss Association of Bankers revealed that approximately a fifth of all banks registered in Switzerland are foreign. For a balance sheet of 17.9 billion francs, 11.8 billion francs represented liabilities abroad and 13.5 billion foreign assets. This means that 33 per cent of foreign assets deposited in Switzerland are in the hands of foreign-owned banks and 31 per cent of investments abroad by Swiss banks handled by these same banks.

The Report further recalls that 28 banks have failed since 1952. Most of the cases happened in the late 60's. For these reasons the Association of Bankers has pressed forward more severe banking legislation. The new law took effect on 1st July, 1971 after having been debated in Parliament. It purports to protect the investor by demanding regular balance sheets of banks and submitting them to regular supervision. A general framework of control has been installed to make sure that banks apply the new provisions of the law.

The Association of Bankers passed a Convention in September 1969 to put a limit on the expansion of credit in the form of loans, mortgages, bills, company overdrafts and notes that this new policy has been highly efficient. Banks have managed to keep to their guidelines and have not allowed their lendings to overstep the bounds that had been fixed. The 1969 agreement has been extended for a third year and will be valid for 1972.

A chain of garages goes bust

"Eurogas" was an important chain of garages selling petrol at special cut-down prices. It was forced into bankruptcy at a special meeting of creditors on 17th September. Officially, the reason for this demise seems to be the uncontrolled growth of the company

since its creation in 1958. The policy of rebates on the cost of petrol, applied in a field of particularly severe competition, proved to be the organisation's undoing. The liquidator will also see whether excessive overheads and lack of cost control had their part to play. About 35,000 holders of buying cards and many thousands of shareholders with 100-franc unit holdings will not be refunded. The firm's 150 employees will however have no difficulty in finding employment in the present favourable situation of the economy.

A wage policy suggested

Mr. Etienne Junod, President of the "Vorort" or Swiss Union of Commerce and Industry, threw a bomb in a speech at an ordinary assembly of the Vorort. Other high personalities, such as the Head of the Department of Public Economy, the President of the National Council and the Director of the Federal Chancery counted among his audience and listened to his much commented suggestion that prices and wages should be controlled in Switzerland. Despite the present credit restrictions and the tough conditions of exports resulting from the recent monetary difficulties. Mr. Junod suggested that management should abstain from all price increases. This would include rent and services, both public and private. Companies would refrain from increasing dividends. For the scheme to work it was of course indispensable that employees abandon all wage claims not matched by an increase of productivity.

Mr. Junod claimed that this solution should not be confused with a prices and incomes clamp-down enforced by the State. However, Mr. Ernst Brugger told him in a subsequent speech that he "had courage", and said that the Swiss economy should progress in the spirit expressed by his speech. But it was impossible for the State to interfere as far in a free economy.

Telegrams and Cables : TRANCOSMOS LONDON

TELEX 24777

Telephone : 01-407 4433 (8 Lines)

COSMOS FREIGHTWAYS AGENCY LIMITED.

INTERNATIONAL FREIGHT FORWARDERS

By Road, Rail, Sea and Air

1, CATHEDRAL STREET,
LONDON BRIDGE, LONDON, S.E.1.

REGULAR GROUPAGE SERVICES WITH

SWITZERLAND

ANGLO-SWISS CUSTOMS EXPERTS.

OFFICIAL FREIGHT AND
PASSENGER AGENTS FOR
SWISSAIR AND ALL AIR LINES
TO SWITZERLAND AND ALL
PARTS OF THE WORLD

ALSO AT
LIVERPOOL, MANCHESTER,
NEWCASTLE-ON-TYNE,
HULL, BRISTOL, CARDIFF,
SWANSEA, NEWPORT, Mon.,
GLASGOW.

CONNECTED
THROUGHOUT
THE WORLD

Agents: WELTIFURRER INTERNATIONAL TRANSPORT CO. Ltd., Zurich, Basle, Schaffhausen, Geneva, St. Gal

TELL WILLIAM, I'd sooner trust my ROAMER

OF SWITZERLAND

Our Target—
Precision Perfection.

Our aim—
Prices within
everyone's range.



ROAMER WATCHES (ENGLAND) LTD.
29-35 Farringdon Rd. London EC1.
01-405 2858

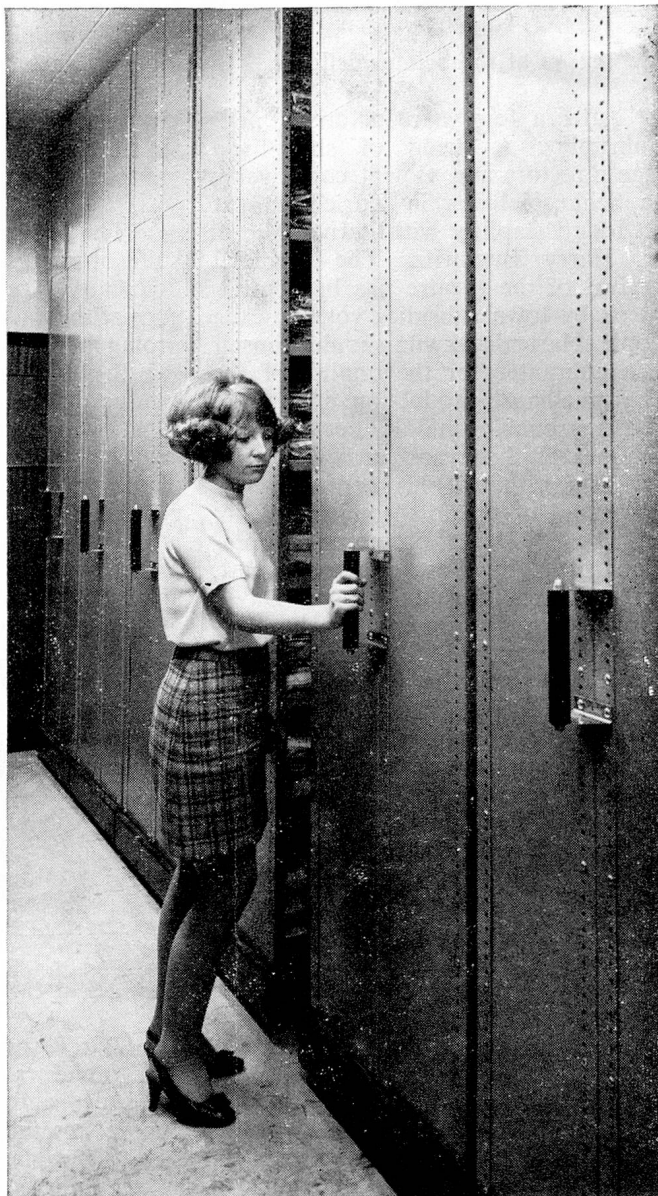

COMPACROW

—the brilliant answer
to your storage problems

Compacrow Mobile Storage Units eliminate the need for space-wasting aisles between individual pairs of racks. Compacrow units glide at fingertip pressure to give you access just where you want it.

You need only one aisle in a whole run of cabinets — you'll double your storage capacity and save money all round.

Our storage experts will be glad to show you how to get more out of your available space. Pick up the phone now, tell us your problems and we'll show you how Compacrow will save you rates, money and space.

ACROW

Acrow (Automation) Ltd., South Wharf, London W.2.
Telephone: 01-262 3456. Telex: 21868.

ARTS

New season at the Schauspielhaus

After a few years of crises, near bankruptcy, a string of short-lived stage directors and violent controversy the Schauspielhaus in Zurich has at last found stability with its new director, Harry Buckwitz. The financial survival of the theatre has been guaranteed by town subsidies voted by the people. Harry Buckwitz should himself be a guarantee for the quality of the Schauspielhaus' production and strike at a reasonable middle between the extremes of the avant-garde and conservatism although his contract ends at the end of the forthcoming season.

The 1971-72 programme comprises plays by Nestroy, Durrenmatt, Garcia Lorca, Pasolini, Gogol, David Storey, Carl Sternheim, Brecht, Edward Albee and Molière. Experiments—and with them the risk of a "scandal"—are confined to the theatre's *Night Studio*, which was appropriately started off last season. The plays to be shown there will be "The Cantonsville Trial" by Daniel Berrigan and "Feast for Boris" by Thomas Bernhard.

The Director Harry Buckwitz has recently won great acclaim with his production at the Zurich Opera of G. von Einem's "Visit of the Old Lady".

Pop art exhibition at the Kunsthaus

The Kunsthaus in Zurich has had two remarkable exhibitions lately. One of them was the art collection of the Dresden Museum, standing out by its unique items of jewellery. It was described in a recent SNTA article in these columns.

The other was a sculpture exhibition by the rising pop artist *George Segal*. The essence of his art is to convey three-dimensional pictures. His themes, typical of which are a man sitting alone in a bar, lovers, an elderly couple walking alongside a brick wall

(the work being in fact entitled "brick wall"), people wandering aimlessly along Times Square at night and a lonely figure looking down upon a city are all depicted as three-dimensional scenes. This means sculpture, furniture, a room and the necessary sets.

The visitor thus walks along a suite of rooms in which these various "tableaux" are represented. The difference with Madame Tussaud is that the protagonists are absolutely anonymous. But they are unbelievably life-like and produced by a method introduced by Segal, which consists in clothing real subjects with pieces of cloth soaked in plaster and then reconstituting their genuine attitudes. The finished product is of white-coated sheet metal, which makes the statues show out vividly against the black setting in which they are usually placed.

Zurich must count as one of the great centres of fine arts. The famed Marlborough Galleries, with showrooms in London, New York and Rome have marked their 25th Anniversary by opening a gallery there. It is admirably situated in the gardens of the Baur au Lac Hotel. The inauguration was followed by a Matisse exhibition.

Changes at the OSR

L'Orchestre de la Suisse Romande, the orchestra founded by Ernest Ansermet and the best known symphonic ensemble in Switzerland, will have a new status. It will be structured as a Public Foundation with membership to the Foundation Council sought among all the French-speaking cantons, the cities of Lausanne and Geneva, the Confederation and the Radio. These members will pay 250,000 francs and thus build up the Foundation. The artistic management of the orchestra as well as its musicians will have a consultative vote at the Foundation Council. The outside orga-

nisms which have not laid out 250,000 francs will be entitled to a representation provided they contribute an annual donation of at least 40,000 francs.

RELIGION

The Protestant Liberals celebrate their Centenary

Theological liberalism, which holds that Christ was nothing more than an inspired preacher, has strong foundations in Switzerland, particularly in the west. The Protestant Liberal Union was founded in 1871 and his Centenary was marked by a ceremony at St. Peter's Cathedral, Geneva, and three days of open theological discussions at the church centre of Cartigny.

Celibacy—a minor setback for the priest

The Catholic Church in Switzerland has carried out a survey among its own ministers which yielded a sociological and human map of Swiss priesthood. About a quarter of the replies came from priests aged between 24 and 40, half came from the 40-60 age group and the remainder from priests above 60.

In the main, the priest is satisfied with his job and would have none other to live according to his faith. He has chosen it freely. Celibacy is not the first of his preoccupations—it comes in seventh position. Those things which worry him most are, respectively: Harassing work, the lack of fellowship, the outdated thinking of the established church, the difficulty of living in a totally secular world, pastoral structures unadapted to present needs, an inadequate formation and, finally, celibacy.

The Report tells the needs and hopes of priests today and thus carries with it a clue to the answer. But tomorrow's priest still has to be made.

English in England

ANGLO-CONTINENTAL SCHOOL OF ENGLISH the leading language school in England

Course Programme available from Anglo-Continental School of English, 29-35 Wimborne Road, Bournemouth BH2 6NA, Tel. Bournemouth 27414; Telex 41240, or Sekretariat ACSE, Seefeldstrasse 17, CH-8008 Zürich Tel. 051/47 79 11; Telex 52529

LONDON OXFORD

1002

Recognized as Efficient by the Department of Education and Science (Ministry of Education) in England. • Official Centre for the University of Cambridge and London Chamber of Commerce Examinations

MAIN COURSES
3-50 weeks, commencing at the beginning of every month

HOLIDAY COURSES
2-8 weeks (June to Sep.), commencing at the beginning of every week

PREPARATORY COURSES
for the University of Cambridge Proficiency Examinations

SPECIAL COURSES
for Secretaries — for Staff in Travel and Tourism — for Bank Employees — for Hotel and Restaurant Staff

HOLIDAY COURSES
at University Centres. Duration 3-10 weeks, July to September

Name _____

First Name _____

Address _____

Town _____ (Postal Coding)

CERBERUS

Swiss national, English mother-tongue, is offered an interesting career in the

TRANSLATION DEPARTMENT

of a forward looking company in the field of electronics, on the

ZURICH "GOLD COAST"

Requirements: Perfect English, thorough knowledge of German, additional languages, technical understanding and previous translation experience definitely an asset.

The position offers independent work and working hours suiting personal needs.

Social amenities, clubs, excellent fringe benefits.

Please apply in writing to:

The Personnel Manager, Cerberus Ltd., CH-8708 Männedorf
giving full particulars on curriculum, salary expectations and references.

Married applicant also welcome.



Cerberus AG
Werk für Elektrotechnik
8708 Männedorf
Telephon 051/739151

**I've always had
a straight
answer
from the
Union Bank
of Switzerland**

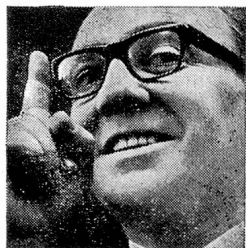

UNION BANK OF SWITZERLAND

SCHWEIZERISCHE BANKGESELLSCHAFT
UNION DE BANQUES SUISSES
UNIONE DI BANCHE SVIZZERE

117 Old Broad Street, London, E. C. 2

**The average
tourist will
drop 2.5 pairs
of gloves
during the
season!**

So it's as well that the Swiss invented Velcro touch and close fastener. A couple of inches sewn to the outside of ski pants and you've a handy place to park your gloves whilst you reach for your ticket.

it's better with
VELCRO
touch and close fastener



Write for sample length to
Selectus Limited, BIDDULPH, Stoke-on-Trent.
Tel. Biddulph 3316

Speed limit of 100 kmh on Swiss roads

After many days of speculation that the Federal Council was going to table a motion demanding a general speed limit on Swiss roads, Mr. Ludwig Von Moos, Head of the Department of Justice and Police, made public the decision by the Federal Council to impose a 100 kmh speed limit on all Swiss roads except motorways. The matter, as it turned out, was not in Parliament's competence and notification had been given as a gesture of courtesy towards the representatives of the people.

The speed ban surprised many motoring correspondents, who claimed that the Federal Council's decision went against the advice of two specialised commissions. Furthermore, both the Swiss Touring Club and the Swiss Automobile Club had been opposed to general and undifferentiated speed restriction. One of the two study commissions had concluded that, although a generalised speed ban would be easier to put into effect, it conflicted with the extreme variety of the ordinary Swiss road network. As for the Office for Road Accidents Prevention, it supported the possibility of separating the network into 90 kmh and 110 kmh limit sectors as a viable alternative to a rigid and universal speed limit.

This speed limit does not allow for an overtaking margin as applied in France. The innovations put forward by the Federal Council are to set up a "documentation centre" on the problems of road safety and to centralise the education of learner drivers. The Government has decidedly proclaimed road safety as a "national and social task of primary importance".

The "Old Lion" abandons politics

The doyen of the National Council since 1953, Mr. Charles Dellberg, 86-years-old, has made known his intention of retiring from political life. He said that the time had come for him to devote a few more years to his family and his garden. The founder of the Valais Socialist Party made his first attempt at entering the National Council in 1919, at a time when many of his fellow parliamentarians weren't even born. His chequered career is sprinkled with anecdotes reflecting his vivacious Valasian temperament. Before engaging in a long political career that saw him successively communal councillor, delegate to the Great Council of Valais and its president and Socialist national councillor, he had been a shepherd, bottle-washer, worker and newspaper salesman.

His retirement was viewed with some relief by the Valais Socialist Party which had another candidate, Mr. Otto Matter, on its list. Mr. Dellberg would have fought in the coming federal elections alone against his own party and have weakened its position.

THIRD WORLD

Mr. Kaiser's hunger strike

Mr. Kaiser, Director of the important charity "*Terre des Hommes*" staged a hunger strike in protest against the Governments' apparent lack of response to his suggestion that starved Bengali children should be interned in Switzerland. At the time of writing his fast had already lasted eight days and he had been publicly rebuked in a telegram sent to him by Mr. Gnaegi, President of the Confederation. Mr. Gnaegi reminded him that efforts had already been made, in vain, to have some of the worst-hit children

sent over to Switzerland temporarily. But both the Indian and Pakistani governments had turned down the proposal. Mr. Gnaegi concluded that Mr. Kaiser would be more helpful to the refugee's cause in being active on-site than by fasting.

Meeting of the dispossessed Swiss

The Association of the Dispossessed Swiss of Algeria held their Annual Meeting in a Geneva hotel. Dr. Louis Guisan, State Councillor and President of the Commission for the Swiss Abroad was present as well as a number of high executives of the Political Department.

As expected, the dispossessed Swiss vented their disappointment at the slowness with which their case was being attended to. Their lawyer, Mr. Canonica, complained that for the past ten years they had been given nothing but promises by the Federal Council. Dr. Guisan, who supported their cause, recognised that a petition in their favour passed by the National Council had not yet been referred to the Council of States. When the President of the Association intimated that the Swiss Parliament, who had just voted a 400-million franc credit in favour of the Third World, should do better to help their own compatriots abroad, Mr. Guisan countered by stressing that the dispossessed Swiss would not help their cause by attacking the Government in the other fields of its policy.

The central problem (as referred to in our report on the 49th Assembly of the Swiss Abroad) is that many thousands of Swiss who have had to leave Algeria have been deprived of the obligatory Old Age Pension to which they had contributed for years. Not having subscribed to Swiss Old Age Pension and being further deprived of their property, those who have not managed to start anew in the motherland are in a difficult material situation. At present they get a helpmeet loan sponsored by the Association of Swiss Abroad, but this they will be held to repay as soon as their means allow it.

Diplomacy is not the art of the impossible

"Politics is the art of the possible, but diplomacy cannot be the art of the impossible". With this introduction, Mr. René Keller, Head of the Division for international organisations at the Political Department, explained why it was wrong to blame the Swiss Government for the failed attempts at bringing East Pakistani children into Switzerland. He was speaking at a Press conference following a session of the Federal Council. He recalled that re-

THE ZURICH GROUP

ZURICH INSURANCE COMPANY
(a limited Company incorporated in Switzerland in 1872)

THE BEDFORD LIFE ASSURANCE SOCIETY LTD.
(an associate member of the Life Offices Association)

THE BEDFORD GENERAL INSURANCE COMPANY LTD
(a member of the British Insurance Association)

UNDERTAKE ALL
CLASSES OF INSURANCE
BRANCHES THROUGHOUT THE U.K.

HEAD OFFICE:
FAIRFAX HOUSE, FULWOOD PLACE
HIGH HOLBORN, LONDON, W.C.1

Telephone 01-242 8833

GROUP RESOURCES EXCEED £500,000,000

fusals had been received from both the Indian and Pakistani governments since Switzerland had offered to relieve them of the refugees' misery in this way last June. He stressed that it was in these governments' opinion as well as Swiss public opinion that the best way to help these destitute people was to bring them aid on the site. Ten million francs had already been used in this way. The Confederation had sent an expert to India and five large Swiss

humanitarian organisations were involved with East Pakistan refugees.

"We are continuing our efforts to have refugees allowed in Switzerland and we won't despair", added Mr. Keller.

These words may have had a salutary effect, for on 29th September, after having held out for a fortnight, Mr. Kaiser decided to call off his hunger strike. He said, quite appropriately, that the intensified care of the hunger-

ing refugees was too urgent for him to remain inactive and fasting. He declared that he was now satisfied that the Swiss Government was doing everything in its powers to give asylum to refugee children.

Although this wish appeared no nearer materialisation, the Swiss Government acted in the right spirit by remitting half a million francs to the International Red Cross the same week.



SWISS BANK CORPORATION

(a Company limited by shares, incorporated in Switzerland)

Principal London Office

99 GRESHAM STREET,
P.O. Box No. 114,
LONDON EC2P 2BR

Tel. 01-606 4000

West End Branch

SWISS CENTRE,
1 NEW COVENTRY STREET,
LONDON W1V 8BR

Tel. 01-734 0767

(Savings Account facilities available)

SOCIÉTÉ DE BANQUE SUISSE

SCHWEIZERISCHER BANKVEREIN

SOCIETÀ DI BANCA SVIZZERA

Offices throughout Switzerland
in New York, San Francisco and Tokyo

FOR *Your*
WORLD
TRANSPORT
(ANYTHING - ANYWHERE)

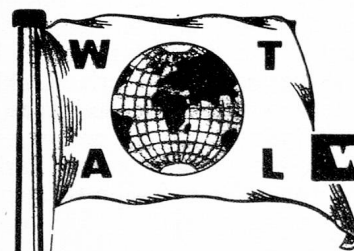

WORLD TRANSPORT

Ask / first!

Tel: 01-928 6996 . Telex: 28401

WORLD TRANSPORT

20/22 EMERSON STREET
LONDON S.E.1.

AIRPORT OFFICES:

LONDON BIRMINGHAM
MANCHESTER YEADON GATWICK

AGENCY LIMITED

Specialized Regular Groupage Services

GREAT BRITAIN - SWITZERLAND and ITALY
and VICE VERSA

BRANCHES: BASLE · MANCHESTER · BRADFORD · BIRMINGHAM · HULL · SHEFFIELD · LIVERPOOL
LEICESTER · STOKE