

Zeitschrift: The Swiss observer : the journal of the Federation of Swiss Societies in the UK

Herausgeber: Federation of Swiss Societies in the United Kingdom

Band: - (1971)

Heft: 1609

Rubrik: Business news

Nutzungsbedingungen

Die ETH-Bibliothek ist die Anbieterin der digitalisierten Zeitschriften. Sie besitzt keine Urheberrechte an den Zeitschriften und ist nicht verantwortlich für deren Inhalte. Die Rechte liegen in der Regel bei den Herausgebern beziehungsweise den externen Rechteinhabern. [Siehe Rechtliche Hinweise.](#)

Conditions d'utilisation

L'ETH Library est le fournisseur des revues numérisées. Elle ne détient aucun droit d'auteur sur les revues et n'est pas responsable de leur contenu. En règle générale, les droits sont détenus par les éditeurs ou les détenteurs de droits externes. [Voir Informations légales.](#)

Terms of use

The ETH Library is the provider of the digitised journals. It does not own any copyrights to the journals and is not responsible for their content. The rights usually lie with the publishers or the external rights holders. [See Legal notice.](#)

Download PDF: 01.04.2025

ETH-Bibliothek Zürich, E-Periodica, <https://www.e-periodica.ch>

THE MISADVENTURE OF A SCOT IN GENEVA

An un-named Scot living in Geneva for the last ten years was shocked by the fact that the Swiss postal services were losing five million francs a year in the administrative cost of handling the prizes of fourth-rank winners on the Sport Toto (Swiss football pool) and the Lottery. He decided that something ought to be done about it and, in all good faith, published an announcement in the papers asking for Sport Toto better to give their opinion. This was an honest personal enquiry. The announcement was printed separately and sent to better holders a Sport Toto or Lottery account.

The management of the Sport Toto reacted immediately. It wrote to its account holders telling them that it hadn't sent the announcement and that the answer slips should not be sent back to Sport Toto. It also lodged a complaint against the Scot for "the abusive use of the names of Sport Toto and Number Lottery" and asked the postal services to block his postal box address.

The Scot reacted with the violence that Scots can show in these circumstances and counter-attacked by suing the Sport Toto for libel. The Court recognised his entire good faith and decided to dismiss the case, a decision against which the Sport Toto has already appealed. There remained the complaint for libel of the Scot. He appeared before the Magistrate accompanied by the talented football champions Philippe Pottier and Roger Bocquet. Sport Toto's representative was absent, but he was excused by a lawyer. The hearing didn't go very far because the Sport Toto lawyer denied all competence to the court. The alleged libel had been committed in Lausanne and Swiss law stated that libel cases have to be handled in the district where they were committed. The fiery Scot had to go home with his sportive escort—until they meet again in Lausanne.

(La Suisse)

OTHER NEWS

The stately railway station at Lucerne has been destroyed by fire. The "Roi Soleil" Hotel at St. Moritz has also been gutted by a fire which fortunately made no victims among the 400 guests. The Christian Social Party has published a manifesto calling for a full-time and salaried Federal Assembly and a coalition government. The eighth revision of the Old Age Pension has been the subject of heated debates at the National Council and the principles of the "three pillars" of old age were upheld. The discussions between Italy and Switzerland on the status of Italian workers which broke down in December will be resumed. The Italians are anxious that their nationals should enjoy the same rights as their Swiss work-mates.

BUSINESS NEWS

MEDICAL ELECTRONICS— A NEW FIELD OF ACTIVITY FOR SWISS INDUSTRY

At the beginning of September, 1970, the Swiss pharmaceutical group Hoffmann-La Roche and the French firm Electronique Marcel Dassault (EMD) signed an agreement on industrial co-operation which opens up new vistas in the field of medical electronics. By the terms of this agreement—which must still be submitted for approval to the French Ministry of Economics and Finance—the medical division of EMD assigns its patents and manufacturing licences to the Swiss firm, which undertakes to exploit them on a world-wide scale.

This is not the first time that Hoffmann-La Roche has signed an agreement regarding medical electronics. The firm first manifested interest in this line several years ago and it is perhaps worthwhile retracing the various stages through which its activities in this field have passed.

The first steps

It was in 1966 that Hoffmann-La Roche first entered the medical electronics field. At that time its interest was directed towards the USA and found support from the Radio Corp. of America (RCA). On the basis of the agreement reached between the two firms the latter contributed the electronics know-how it had acquired in its space research work and Hoffmann-La Roche made available its medical and commercial infrastructure. It was not very long, however, before differences of opinion arose as to the form the collaboration was to take and in 1968 the two partners decided to separate. Hoffmann-La Roche resumed possession of the joint subsidiary which had been set up in the USA and decided to concentrate its research work at its Basle headquarters. It was nevertheless plain that the activities of the Swiss firm in medical electronics, which was a new field of operations for it, could be successful only if they were backed by an adequate technical infrastructure. It was for this reason that it sought to join forces with new partners.

In quest of a technological infrastructure

A first step in this direction was taken in 1967, when Hoffmann-La Roche was able to secure a 25% holding in the capital of the Société Genevoise d'Instruments de Physique (SIP). This firm specialises in the manufacture of high-precision apparatus and enjoys a world-wide reputation. Its experience in this field helped to pave the way to the manufacture of instruments of the highest precision capable of meeting present medical standards.

Once it had assured itself of the experience of SIP in micromechanics, Hoffmann-La Roche had to find a partner that could supply the necessary

electronics infrastructure. Negotiations with Brown, Boveri & Company Ltd. in Baden led to an agreement being signed in June 1969 by the terms of which the two firms covenanted to collaborate in the development of instruments and apparatus for medical electronics.

It was natural that the Basle chemical group should see in Brown Boveri, the Swiss electrical engineering giant, a partner capable of supplying the electronic know-how it needed. More than 10% of the Baden company's turnover is in the electronics field, which it is anxious to expand. Moreover, it has a holding in Faselec, a company formed a few years ago on the initiative of the Fédération Horlogère and specialising in miniature circuits. Finally Brown Boveri has perfected the famous "beta-trons", which are used in the treatment of several diseases and, in the latest versions, develop an energy of 45 million electron volts. Today Brown Boveri, along with Siemens, is still the only firm in the world manufacturing these apparatuses.

The creation of this triangular "pool" assembling Hoffmann-La Roche's knowledge in the medical field, Brown Boveri's in electronics, and SIP's in micromechanics, is the upshot of a long process which has led Swiss industry to concentrate its efforts in those specialised sectors in which it particularly excels. All the same, medical electronics is an *avante-garde* sector where a great deal of spadework remains to be done. It is for this reason that, on the conclusion of the agreement between Hoffmann-La Roche and Brown Boveri, the assumption was that the collaboration between the two firms would initially take the form of research work aimed at exploring the possibilities of applying electronic techniques to medicine and biology. It was anticipated that a number of years would elapse before actual manufacturing of the apparatus could be taken in hand and a pivotal role was assigned to SIP in this connection. However, the recent agreement with Electronique Marcel Dassault alters the situation to the extent that it now seems likely that the manufacturing stage, i.e. the production of medical apparatus, will be reached more rapidly than had been originally thought.

Dassault products fill a gap

By assigning its patents and licences to Hoffmann-La Roche, Electronique Marcel Dassault is in fact giving up the manufacture of medical apparatus whereas the Swiss group acquires the right to exploit the apparatus in question commercially. Mainly concerned are the "Monitor V", an apparatus permitting simultaneous surveillance of several patients and already installed in a number of hospitals, the "Groupomatic", an apparatus for automatic blood-grouping highly rated on the world market, and various other instruments. Thus, for the first time in

your home your office your factory

Sulzer's international experience solves heating problems in Britain

Sulzer's services range from industrial heating and ventilating contracts to a unique thermostatic radiator valve for use in domestic central heating systems. This valve, which is helping British families to get more economy and comfort from their central heating, is called Temset. Set it to the temperature you want — and from then on it keeps the room at that level of heat. Temset even makes adjustments to compensate for the number of people in the room and changes in the weather.

Sulzer Bros./London/Ltd., Bainbridge House, Bainbridge Street, London W.C.1.

SULZER

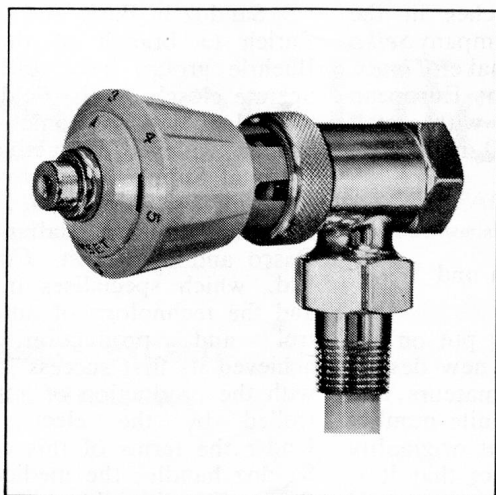
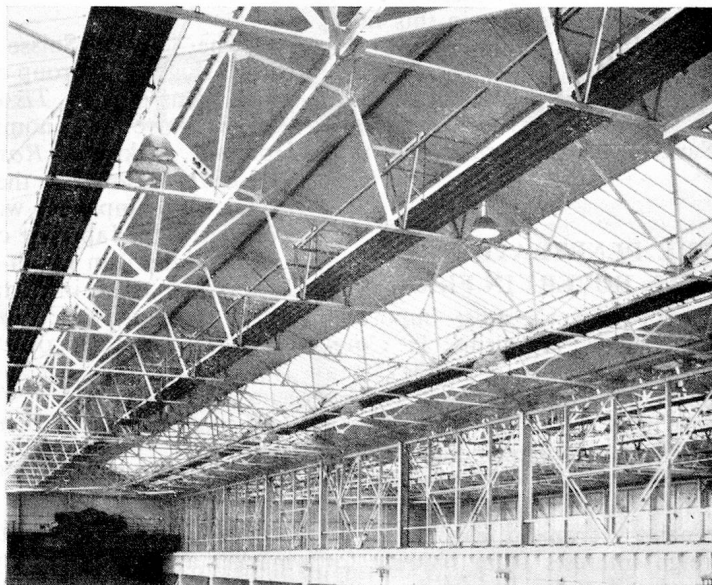
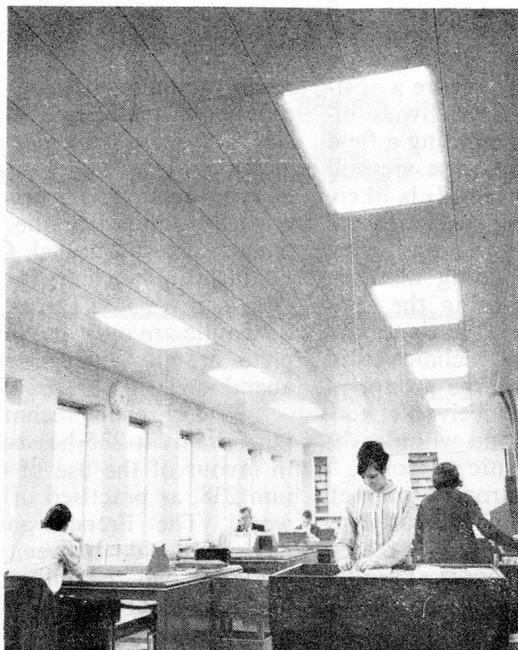

TEMSET

the medical electronics field, Hoffmann-La Roche has at its disposal apparatus which can be placed on the market at once.

This confers a not inconsiderable advantage on the Swiss firm. Research, particularly in a firm in which electronics does not figure importantly, is costly and a considerable time elapses before the results can pay off. By reason of the tight specialised commercial network at its disposal, Hoffmann-La Roche is in a position to promote the sales of Dassault products. Consequently the medical electronics sector will not merely incur research expense but will also earn a substantial return before very long. It is in this sense that the Dassault products will fill a gap.

Swiss industry enters a promising field

The ties with the Société d'Instruments de Physique, the agreement with Brown Boveri, and the purchase of the Dassault patents attest Hoffmann-La Roche's determination to secure a position in medical electronics. Swiss industry can thus be seen entering a field where, although the first steps are still hesitant, the future is bright. It is likely that steadily increasing use will be made in future of electric and electronic apparatus for refining methods of diagnosis, for monitoring the conditions of the seriously ill patient, and finally for applying the techniques of preventive medicine to large groups of the population. It is conceivable, too, that apparatus of this kind will also be used for purely therapeutic purposes.

The medical electronics market, dominated in Europe particularly by the Siemens (Germany), Philips (Netherlands), and Thomson (France) groups holds out some interesting prospects. In view of the present efforts being made by Swiss industry, there is every ground for believing that, in this field, the technology of tomorrow will be greatly indebted to our country.

(by courtesy of "Prospect",
Swiss Bank Corporation Survey)

THE PENETRATION OF BROWN BOVERI IN FRANCE

One of France's most important electrical engineering firms, la *Compagnie Electromécanique (CEM)*, is a subsidiary of Brown-Boveri, Baden. For some time, *CEM* has been seeking to reach a merger agreement with the French *Jeumont-Schneider* electrical group. This has so far been opposed by the French government, eager to stave off foreign interests from bidding for key French industries. In fact, *Jeumont-Schneider* was already in foreign hands, as it belonged to a Belgian industrialist, the Baron Empain, who had sought in vain to sell his 60 per cent share of the company to the American Westinghouse corporation. Brown-Boveri had already linked (through *CEM*) with the *Jeumont-Schneider* group in two ways.

CEM has passed an agreement with the heavy electrical engineering and recently formed *Creusot-Loire* consortium according to which *Creusot-Loire* will be using Brown-Boveri turbine licenses as a preliminary step to closer co-operation. *Creusot-Loire* is 50 per cent under the control of *Schneider*, which has a 40 per cent stake in *Jeumont-Schneider*. Secondly, *CEM* has passed an agreement with *Jeumont-Schneider* and *Péchiney* for the construction of nuclear reactors.

In order to safeguard the French identity of *Jeumont-Schneider*, the French government has tried unsuccessfully to merge it with the only other comparable French company, *La compagnie Générale d'Electricité*. All the experts agree that a deal with *CEM* would be far more advantageous. One cogent reason for this would be that *CEM* has obtained very important contracts for Brown-Boveri turbosets (of 1190 and 460 MW of power) from America and will need to expand its production facilities to carry them out. As *Jeumont-Schneider* is working under capacity and has a complementary production, a merger would offer great advantages in the short term. It remains for the French Government to establish a nuclear industrial policy once and for all. The days of General de Gaulle are over and the idea of complete atomic independence has been abandoned.

The French technique of using pure uranium 235 has been abandoned in favour of the use of enriched uranium 238, as practised in the rest of the world. The French government will have to decide between economic expediency and the military or patriotic advantages of keeping France's electrical industry entirely French.

The "Société Suisse pour l'Industrie Horlogère", a group comprising the watch firms *Omega*, *Tissot* and *Lanco*, has taken over "Economic Swiss Time Holding", makers of *Roskopf* watches. The SSIH group was the third largest maker of completed watches in the world after the Japanese company *Seiko* and the American watch-maker *Timex*. It was the most important European watch company in Europe with a staff of 6,700 and sales of £50 million in 1970.

A new Saw for Handymen and Model-Makers

A Swiss firm recently put on the market a saw of entirely new design, which will allow both amateurs and professionals to do an infinite number of different jobs. The great originality of this saw lies in the fact that it is equipped with an electromagnet and not a conventional motor; this revolutionary new design has the advantage of doing away with maintenance and lubrication and at the same time en-

suring exceptional long life. This handy, silent light saw — its weight varies from 3.5 to 5 kg. (7½ to 11 lb.) depending on the model — is ideal for many purposes: it saws with remarkable precision and neatness all kinds of wood as well as resin, plastic, nylon and even metals. Its blade can be replaced by a fine file, so that it can also be used to make prototypes, in precision engineering and the watch industry.

(OSEC)

A Swiss Technological Pioneer

Although it is difficult to calculate the exact extent of the market of the Mettler group at Greifensee (Canton of Zurich), one thing is definite and that is that nearly two-thirds of the analytical and precision balances sold in the world today are Mettler balances. This firm, founded 25 years ago, has revolutionised laboratory weighing methods the world over. In fact, almost all the balances manufactured today are no longer based on the traditional principle of compensation but on that of substitution, perfected by Erhard Mettler, the founder of the firm. The new weighing method makes it possible to measure with very great accuracy not only constant weights but also the weight of the mass, to analyse its behaviour under the effect of very big variations in temperature, corrosive gases, etc. It is interesting to note that NASA uses Mettler thermoanalysers for testing certain materials sent out into space. In Switzerland the Mettler group is composed of four companies, one of which goes in exclusively for perfecting and manufacturing optical scales for high precision measuring instruments. Let us also mention that out of 1,200 people working for Mettler, including those based in Germany, the Netherlands and the USA, 150, i.e. 12% are employed exclusively in research.

Co-operation in the Field of Technology

Sandoz in Basle and Contraves in Zurich (a branch of the Oerlikon-Buehrle group) have decided to co-operate closely in the field of medical technology and electronics. A year ago Sandoz widened its activities in the Hospital Supply sector by purchasing the American company J. J. Monaghan Inc. and the two Italian companies Dasco and Sterilplast. Contraves Co. Ltd., which specialises in electronics and the technology of automatic control and production techniques achieved its first success in this sector with the production of a syringe controlled by the electro-cardiogram. Under the terms of this co-operation, Sandoz handles the medical aspect of the appliances and entrusts their marketing to its Hospital Supply division, while Contraves is responsible for their technical development and production.

(OSEC)