

Zeitschrift: The Swiss observer : the journal of the Federation of Swiss Societies in the UK

Herausgeber: Federation of Swiss Societies in the United Kingdom

Band: - (1972)

Heft: 1648

Rubrik: Swiss events

Nutzungsbedingungen

Die ETH-Bibliothek ist die Anbieterin der digitalisierten Zeitschriften. Sie besitzt keine Urheberrechte an den Zeitschriften und ist nicht verantwortlich für deren Inhalte. Die Rechte liegen in der Regel bei den Herausgebern beziehungsweise den externen Rechteinhabern. [Siehe Rechtliche Hinweise.](#)

Conditions d'utilisation

L'ETH Library est le fournisseur des revues numérisées. Elle ne détient aucun droit d'auteur sur les revues et n'est pas responsable de leur contenu. En règle générale, les droits sont détenus par les éditeurs ou les détenteurs de droits externes. [Voir Informations légales.](#)

Terms of use

The ETH Library is the provider of the digitised journals. It does not own any copyrights to the journals and is not responsible for their content. The rights usually lie with the publishers or the external rights holders. [See Legal notice.](#)

Download PDF: 01.04.2025

ETH-Bibliothek Zürich, E-Periodica, <https://www.e-periodica.ch>

SWISS EVENTS

FEDERAL

Planned constitutional article on Radio and TV

The Swiss Broadcasting Organisations and the GPO are currently examining four separate reports on a draft Constitutional article on TV-Radio news media. The original report prepared by a Professor Hubert, differs from that of a document drafted by the Department of Transport and Communications and two further reports by university professors.

These differences and the enlarged dossier have called for a renewed examination of the issues involved.

One of the main concerns of the promoters of an article on broadcasting is to ensure freedom of expression on radio and TV.

Mr. Celio at the Comptoir

Mr. Nello Celio, President of the Confederation, inaugurated the 53rd Comptoir Suisse in Lausanne with a long address dealing with the three main themes: defence, values and inflation.

He defended the decision not to buy either the Corsair or the Milan jet fighter and claimed that it hadn't

reflected a lessening of Switzerland's will to defend herself. "Although military defence is a priority, it is not a dogma", he said, before underlining the basically political and civic nature of our national defence. The most important was to do everything in our power to promote acceptance of the Army among a vast section of the population presently disinterested in its fate, or hostile to it, and prevent our forces from becoming the instrument of a minority.

"We should not forget that our essential task is to create and preserve an ethical community caring for order and unity and opposed to disorder and permanent dissent". Mr. Celio said that the structure of our society couldn't resist unchanged to the "dynamics of our time". A renewal was necessary.

Raising the problem of inflation, he said that the monetary measures that he had taken earlier this year would have only gradual effects. He said that the 1972 budget had been amputated by 600 million francs owing to inflation but had just been balanced. Mr. Celio said this would not be the case of next years' budget if inflation was not checked before.

Schulthess lashes out

Nearly three weeks after having resigned, Mr. Heiner Schulthess, Chief of the Armaments Division of the Military Department, which was responsible for the evaluation programme of the new jet fighter, voiced his displeasure over the outcome of the Milan-Corsair affair in an article in the "Schweizer Illustrierter".

He said that years of work had been thrown in the dustbin and that everything had to be restarted from scratch. He maintained that it was not the job of politicians to make technical decisions. Given a guideline and the principle that we should have an army worthy of the name, then it should be for the professionals to handle the details.

Mr. Schulthess recalled that the expense for the new aircraft had been budgeted and that the Federal Council's final decision was a "fiasco". He added that by restricting all new arms programmes to an expenditure ceiling, i.e. by putting financial principles before defence principles, one would not prevent the Swiss army's deterrence from becoming a "farce".

Radio Rates go up

The Federal Council has accepted recommendations by the broadcasting authorities and allowed Radio and TV licence increases from 40 to 60 francs and from 84 to 120 francs respectively as from next year. This was the only way of averting an otherwise inevitable

For the practical
fastening of
practically anything...
use Velcro.

Velcro, the unique touch-and-close fastener that's the most useful addition to the work basket since the needle.

Available in $\frac{5}{8}$ " and $\frac{7}{8}$ " widths and 14 colours.

Ask for free sample and our 'Velcro' ideas booklet, full of exciting uses for this versatile fastener.

VELCRO®
touch and close fastener

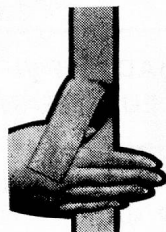

Sole U.K. manufacturers
Selectus Limited, BIDDULPH, Stoke-on-Trent.
Telephone Biddulph 3316



TRAVEL TWICE MONTHLY TO AND FROM SWITZERLAND AND ENGLAND

Providing DOOR TO DOOR SERVICES
with vans specially equipped to carry
— Household Removals. — Exhibition Goods..
— Works of Art. — Machinery.

For full information contact

In Switzerland

KEHRLI + OELER LTD.,
3001 Berne,
Bubenbergplatz 9.
Tel. 031 22 00 22.
Telex. 32414 Kerolch

In England

LEP PACKING LTD.,
Corney Road,
Chiswick,
London, W.4.
Tel: 01-995 1300

deficit, which would have reached 18 million francs in 1973. There is no more scope for increasing advertising time before the renewal of the Broadcasting Corporation's concession in 1971 and it is likely that more advertising will meet strong opposition.

German leaders visit Switzerland

West German Chancellor Willy Brandt and President Gustav Heinemann, visited Switzerland at the end of September. Mr. Brandt spoke at the Annual Congress of the Swiss Socialist Party at Interlaken. His address was centered on the future of Europe and the necessity of progressing towards monetary union by creating a European Monetary Fund.

President Gustav Heinemann, who was accompanied by West German foreign minister Walter Scheel visited Berne and Geneva. He met Mr. Nello Celio the Federal President, and other Swiss members of the Federal Council. He was invited to attend a sitting of the National Council while he was debating on the future of the Cavalry. During a conversation with Mr. Ferruccio Bolla, Chairman of the Council of States, and other officials, he noted jokingly that Berne was being ruled by men coming from the Tessin. An Italian-speaking official answered that this was "because the Tessin is run by Germans. . ."

From Berne, President Heinemann moved on to Geneva, where he was greeted by Geneva officials. He visited the World Council of Churches and the Headquarters of the International Red Cross. Mr. Walter Scheel, who had talks with Mr. Pierre Graber, his Swiss counterpart, held a press conference in Berne during which he expressed interest in a Swiss plan for settling differences which will be submitted to

the future European Security Conference.

Giant country-wide manoeuvres

Wide -scale army manoeuvres involving over 30,000 men, hundreds of war planes and armoured vehicles were staged over the whole of Switzerland during the last week of September. The original feature of this exercise, besides its size, was the use of a central computer in Zurich which stored and channeled information on the position and behaviour of troops. The various military engagements were monitored by over 700 military "referees" who transmitted their observations by telephone, telex or messenger to the nerve centre of the manoeuvres at Dubendorf.

CANTONAL

Trial of the Naters-Blatten Disaster

Four persons went on trial at Brigue in connection with the accident which cost the lives of six spectators at the Naters-Blatten motor-race in June 1969. Those in the dock were the Chairman of the Organising Committee, the Race Controller, a police security chief and the driver of the 7-litre Ford Cobra which had ploughed into a crowd. The accident took place in a straight stretch of the track and killed six people, four of them children, and wounded seventeen. The driver was uninjured.

Films and colour-slides were shown during the hearing to ascertain why the driver, a doctor from La Chaux-de-fonds, had lost control of his vehicle after scraping a grassy patch on the side of the track.

The indictment had been particularly harsh on the organisers. It claimed that the public had been insufficiently informed of out-of-bounds areas and that the organisers had relied on teenagers with no distinctive markings to handle the 6,000-strong crowd. Moreover, the indictment stressed that all signposts were in French whereas the race was being staged in a German-speaking part of the Valais. It was also alleged that the organisers should have been present at the Pre-Race trials so as to make final security arrangements.

The two main organisers and the police officer responsible for security, were sentenced to suspended sentences ranging from 40 days to 5 months imprisonment. The pilot of the racing car was acquitted but fined 800 francs.

Cantonal votes

Votes on cantonal and communal issues were staged in most parts of Switzerland on the weekend of 24-25th September, when the Swiss people rejected an arms-ban initiative by a narrow majority.

In Basle and Geneva, proposals to give the right of vote to young people of 18 were defeated. New delinquency laws were approved by a strong majority in Berne. The people of Thurgau agreed to building of the Toggenburg Railway. Zurich legalised concubinage by a two-to-one majority. The women of Obwald will henceforth benefit from the right to vote on cantonal matters. The voters of Schwytz approved new constitutional provisions on the maintenance of law and order and Uri increased children allowances. Among various communal votes, Saint-Gall's citizens accepted the opening of shops at night, and those of Winterthur voted in favour of building a municipal theatre seating 800.



NEALE & WILKINSON LTD.

Member of the Constantine Group

**REGULAR ROAD SERVICE TO SWITZERLAND
AND OTHER EUROPEAN COUNTRIES**

LLOYDS BUILDINGS, EMPSON STREET BOW, LONDON E3 3NB
TEL: 987 4011/2 TELEX: 897 330 STENCILLER

International Household Movers, Fine Art Packers and Shippers



Members of Eurovan

your home your office your factory

Sulzer's international experience solves heating problems in Britain

Sulzer's services range from industrial heating and ventilating contracts to a unique thermostatic radiator valve for use in domestic central heating systems. This valve, which is helping British families to get more economy and comfort from their central heating, is called Temset. Set it to the temperature you want — and from then on it keeps the room at that level of heat. Temset even makes adjustments to compensate for the number of people in the room and changes in the weather.

Sulzer Bros./London/Ltd., Bainbridge House, Bainbridge Street, London WC1A 1HS

SULZER

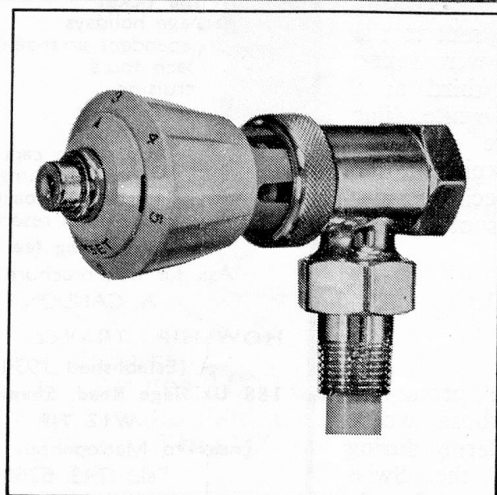
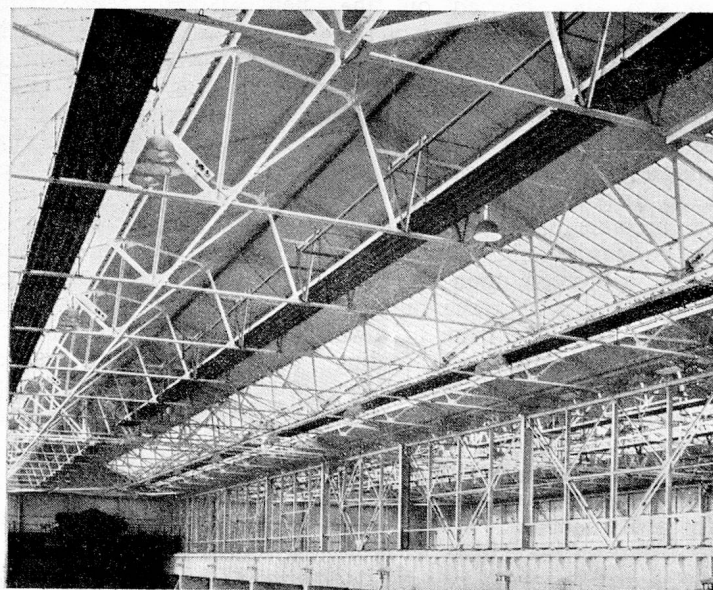
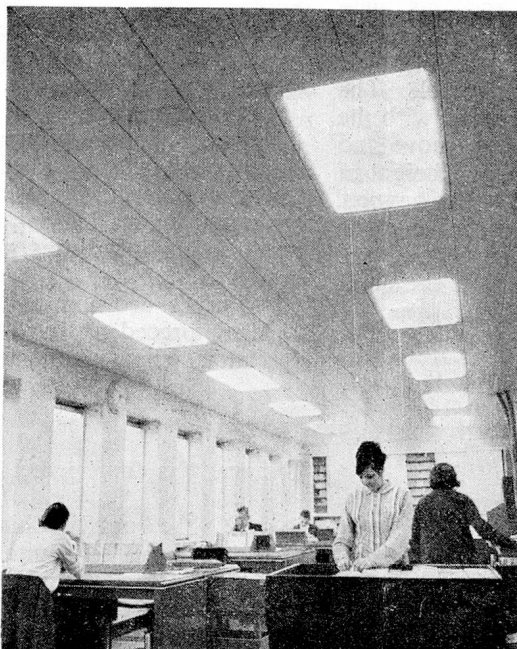

TEMSET

How to fight pigeons

Public opinion in Neuchatel is deeply divided on how to deal with the town's overflowing pigeon population.irate homeowners are eager to see war declared on the birds who soil their property and damage their buildings.

Neuchatel authorities thought they had a solution: To mix sterilising products with feed grain. This method was about to be tried when the Cantonal Hunting Inspector put a stop to it, reminding them that some pigeons were victims of birds of prey. These birds, would in turn, be sterilised and risk disappearing, as so many of their kind are threatened by extinction.

Lucky escape

A young father and his wife parked their car next to the River Doubs to take a stroll and left their six-year-old son in the vehicle. The child, alone in the car, played with the handbrake and it began to move and crashed into the river from a height of 12 metres. The father saw this happen, took off his jacket, and dived into the icy-cold water. He managed to save his son but the car is still in the black waters of the Doubs.

Drugs theft in Berne

The most important drugs theft ever recorded in Switzerland was committed on a Friday night in September at the Federal Public Hygiene Laboratory in Berne.

Thieves, thought to belong to an international drugs ring because of the proficient way they carried out the job, broke into the laboratories of the building without leaving any trace anywhere inside the premises and took about 700 grammes of pure heroin, 400 grammes of hashish and 2,000 ampulles of opium. They also took away the card file relating to these drugs.

The caretaker had left everything in order on Friday night but found the front door forced open the next morning. It appears that the burglars took the necessary keys from his own office and had some trouble in finding the right one to open the laboratory, one of many in the building, specialised on narcotics research. The missing drugs constituted a working batch, the main reserve was kept in the vaults of a Berne bank.

Spiked tyres and over-lapping laws

The Canton of Vaud is contemplating new regulations to limit the use of spiked tyres, because of the

damage they cause on roads. Spikes offer a certain guarantee against skids on icy surfaces, but when roads are cleared, any sharp break will transform a car into a toboggan and make it damage the surface.

The Great Council of Vaud has passed by a vast majority proposals submitted by the Canton's Executive to impose a 100 franc tax on users of spiked tyres and fines of up to 150 francs or more on those who contravene the new regulations. A quarter of the proceeds of the new tax would go to the Communes of Vaud.

A similar plan had been rejected in Lucerne. Delegates to the Cantonal Parliament had found that Article 37 of the Constitution was an unsurmountable obstacle. It says that only the Confederation is entitled to levy taxes on roads but that it can make exceptions (the only one being the Great Saint Bernard Road). But Vaud's authorities retaliated with Article 105 of the Federal Law on Road Traffic, which allows Cantons to tax vehicles bearing their registration on their territory.

As a counter-argument, it is possible to quote Article 4 of the Federal Constitution, which says that all Swiss are equal before the law, and may not enjoy unjust privileges wherever they may live . . .

Vaud's decision may turn out as a legal precedent in a fairly widespread campaign against spiked tyres.

Geneva gets four parcel bombs

Of the nearly thirty envelopes that were sent to capitals of Europe, Asia and Africa and discovered in time, four were mailed to Geneva. Three were addressed to the permanent Israeli representative to the United Nations, the fourth was mailed to a Geneva personality totally unconnected with Israeli circles. A letter bomb of the type that killed Mr. Shashori in London had killed a Geneva policeman last year in a similar incident.

Two of the envelopes sent to the Israeli mission in Geneva were found at Cointrin Airport, the third at a postal sorting office. The white, lilac and pink envelopes were examined by an X-ray. One was exploded, the other two were sent by special courier to the Police Laboratories of Zurich.

Death of Fritz Glarner

Fritz Glarner, the most prominent Swiss painter abroad, whose works had been exhibited in Berne during the 50th Assembly of the Swiss Abroad, died on 18th September in Locarno, aged 73.

Born in Zurich, Fritz Glarner

had lived in Naples, and then in Paris, where he had known and worked with many of the world's leading modern artists. Having returned to Zurich, he associated with progressionist artists later known as the Zurich Concrete Group. He was a close friend of Max Bill. The deceased had then left for New York and lived there until last year, when he decided to settle in Locarno. Most of his works are to be found in American and Swiss museums and collections.

Albert Einstein and Berne

The third series of the PTT's occasional issues of postage stamps featuring famous people appeared in September this year. The 40c-stamp of the 1972 portrait series, designed by the painter Hans Erni, shows the physician Albert Einstein (1879-1955). The life and work of this great scientist have the closest links with Berne. Here he stayed and worked from 1902-1909, as an official of the then Federal Patent Office. In his flat at Kramgasse 49, he carried out the studies which were the basis of his world reputation. From his Berne years alone we know of 32 scientific publications by Einstein. In 1905, his dissertation on determining the dimensions of molecules was written, as well as his work on the photo-electric-effect law, which won him the 1921 Nobel prize. In Berne, Albert Einstein also set up house with Marily Mileva and established a family; his first son, Hans Albert, was born here on 14th May, 1904. Einstein always said that he passed the most pleasant time of his life in Berne. As a memorial to the influence and importance of Albert Einstein in the Federal

YOUR TRAVEL IS OUR BUSINESS

by air - coach - rail - sea
ANYWHERE IN THE WORLD

just the ticket
package holidays
independent arrangements
coach tours
cruising
car ferries
motorail
self drive cars
party bookings
private coaches
hotel reservations
no booking fee

Ask for free brochure from
A. GANDON

HOWSHIP TRAVEL AGENCY
(Established 1934)

188 Uxbridge Road, Shepherds Bush
W12 7JP

(next to Metropolitan Station)
Tel.: 743 6268

MEMBER OF ABTA

capital, the flat in Kramgasse is now to be restored to its original condition and made available for the public to view. With the establishment of an "Einstein House", Berne hopes to fulfil its duty to the memory of the famous scientist. Television viewers abroad already know the house: the British BBC and the French ORTF have both made location shots in Berne for television films on the life and work of Albert Einstein.

World Congress of Secretaries in Berne

From 29th October to 4th November, 1972, in the Hotel Bellevue-Palace in Berne, the World Congress of Secretaries takes place for the first time—bringing together an expected 250 participants from 21 countries. Attendance at the world assembly is open to all professional secretaries from large and small businesses, national and multinational enterprises and organisations, provided these secretaries have several years' experience as well as basic occupational training. The congress aims to give the participants the opportunity to further their education and exchange information and opinions with their professional colleagues from other countries.

Most Modern Congress Centre for Berne

In November this year, the Alfa Congress Centre starts operations at Laupenstrasse 15 in the City-West complex. Berne thus gets one of the most modern conference and congress centres in Switzerland with assembly facilities for 20 to 550 participants. There are also simultaneous translation installations for four languages, microphone and loudspeaker units and soundfilm as well as tape-recorder installations available. The working rooms are all fully air-conditioned. As for accommodation for the congress participants, a residential hotel of middle-range (moderate) prices is also available; each hotel room has bath, telephone, radio and television. In the City-West business centre, there is an underground garage with 800 places, numerous restaurants, two cinemas, a John Valentine Fitness and Health Club, a travel agency and the air terminal for the Berne-Belpmoos Airport. The unbeatable position of the Alfa Congress Centre in the heart of the city—three minutes from the main Berne railway station, tram and coach connections (as well as the regular shuttle service by Swissair Coach to Zürich-Kloten)—make this new facility especially attractive.

Unusual theft

A lorry driver from Zurich transporting 8 tons of plastic statues of Jesus Christ from Montese (Italy) to Stuttgart, had his vehicle stolen as he was eating a plate of spaghetti in Milan.

Frauenknecht set free

Alfred Frauenknecht was set free after spending three years in prison for having divulged to the Israeli authorities, for the sum of £80,000 the blueprints of the engines of the Swiss built Mirage 111-S jet fighter. He almost immediately gave an interview to the Israeli Radio and stressed his admiration for the Jewish State. "I have always felt great attachment to the Israelis and admire the way they have built their country," he said.

Mr. Frauenknecht said that he had studied the history of the Jewish people during the Second World War and criticised the "bad behaviour" of the Swiss, who, he claimed, had not done all they could to save the Jews from the Nazis.



Überall das gleiche—MAT!

Every country in Europe knows that MAT means fast reliable freight to and from Europe, in and around Europe. Because MAT serves Europe completely.

MAT operates 2,000 containers and 450 trailers, by rail and road, door to door, to and from any town in the UK and virtually any town in Europe.

MAT operates full load and groupage, reliably, quickly, with the minimum of paperwork. Get on to MAT now. Get a reliable name in the freight business on your side. Danke schön.

MAT Transport Limited, Arnold House, 36/41 Holywell Lane, London E.C.2.
Telephone: 01-247 6500.
Telex 886384 and 883225

MAT
Serves Europe completely

Re-opening of the Mattmark Trial

The Mattmark Trial, one of the longest and most complicated of Swiss legal history, was re-opened on Wednesday, 27th September, only seven months after having been held a first time at Visp, six years after the disaster which cost the life of 88 engineers and workers at the Mattmark hydraulic dam site. The first trial had led to the acquittal of the 17 accused. The lawyers of the victims' relatives and the attorney in charge of the case, complaining over the leniency of the original verdict, had asked for a re-trial, which was held at the Valais Cantonal Court. The defence demanded the acquittal of the 17 accused with even more emphasis than at the Visp trial.

MODERN LIFE

New Commander for Swiss Guard

Colonel Robert Nünlist, Commander of the Swiss Vatican Guards, has resigned on health grounds. Aged 61, he had assumed these responsibilities for 15 years. Although he had suffered a heart attack last year, he had resumed service in April 1972.

Hailing from Aarau, Colonel Nünlist had been attacked in 1959 by a former Swiss Guard demanding to be redrafted in the Service from which he had been dismissed. He fired two bullets at him. Colonel Nünlist was only slightly wounded.

His successor, the 29th Commander of the 466-year-old Guard, whose essential task is to protect the Pope, is Lieutenant-Colonel Franz Pfyffer Von Altishofen. Aged 50, Colonel Pfyffer has served in the Swiss Army. He is the 12th member of his family to have held this post at the Vatican. The Swiss Guard has at present some sixty members.

Package Tour mix up

Several hundred Canadian tourists were stranded in Switzerland in another case of non-respect of charter flight legislation.

A Canadian package holiday group had chartered a Balair DC-8 jet liner for transporting tourists from Canada to Switzerland and Hungary. During a routine check, the Federal Air Office realised that many passengers transported by the group on the return route had not been on the in-

coming flight. This was, in fact, a breach of charter flight regulations.

The Federal Office ordered a halt of trans-Atlantic Balair flights affecting all those passengers who had not been brought by the company to Switzerland. Thus several hundred impecunious passengers were stranded without any means of paying for their journey home. Eventually, the Swiss and Canadian authorities offered them a special cut rate for the return.

At the same time, the Canadian authorities took similar measures, but in the Europe-Canada direction, and temporarily grounded a Balair airliner at Montreal Airport while the company was ordered to pay a sum of several hundred thousand dollars as a surety for alleged unpaid debts. Balair obliged but filed a suit for fraud, claiming that the Canadian package tour had paid them with a dud cheque. The company sent two men to Montreal to clear up the matter.

Cars registered in Switzerland

There were 1,482,000 cars in Switzerland at the end of last year, during which 225,000 new cars had been bought at the cost of 2.7 billion francs. An enquiry has shown that new cars accounted for most of this fabulous market, which reflects Switzerland's prosperity. 29 per cent of the members of the Swiss Touring Club changed cars every year, 9.9 per cent of them buying a second-hand car, and 19.1 per cent brand new.

The British share of Swiss car imports fell to only 6.9 per cent in the first half of this year, compared with 10.5 per cent in the corresponding 1971 period, and took fifth place as a supplier after Germany, France, Japan and Italy.

There has been a further striking increase in the number of Japanese cars sold in Switzerland. Their share rose to 16.1 per cent, as compared with one of only 9 per cent in the first half of last year. Toyota were second only to Opel as the leading brand of car imported into the country in January-June, 1972.

About democracy

The Great Council of Canton Berne rejected a proposal to lower the voting age to 18 in communal matters. Holding their September session, delegates rejected the idea by 90 votes to 78.

In Schaffhausen, delegates to the Great Council turned down a motion

calling for an end to compulsory voting and participation at communal assemblies. The Cantonal Parliament felt that these democratic obligations should be maintained by 47 votes to 13.

Welsh team visits Switzerland

A delegation of Welsh businessmen, trade unionists and local councillors led by Mr. Peter Thomas, Secretary of State for Wales, made a promotional tour of Switzerland. Under the auspices of the British-Swiss Chamber of Commerce, they held seminars in Zurich, Berne, Basel and Lausanne with the purpose of presenting Wales and its advantages to Swiss businessmen willing to invest in new plant abroad. Owing to the pull-back from coal, unemployment runs high in Wales, despite considerable progress in the engineering and steel industries. The Welsh team made particular reference to the good working spirit in Welsh factories (90 per cent of foreign firms established in the province have never been affected by strikes) and recalled the considerable incitement to invest in development areas in Britain. New industries are offered loan and training facilities and are refunded up to 22 per cent of investments in new equipment. There was plenty in these proposals to attract Swiss industrialists plagued by a chronic shortage of labour.

Tanner, or the 16-mm mobility

The Swiss cinema almost entirely hinges on three names: Alain Tanner, Michel Soutter and Claude Goretta. These are the only Swiss film producers whose works have made an impact abroad, particularly in France. Alain Tanner is probably the best known of

SWISS SPECIALITIES

SAUSAGES

CHEESE

CHOCOLATES

HERO CONSERVES

BISCUITS

ROCO CONSERVES

go to

BARTHOLDI'S

Charlotte Street, London W14

Telephone: MUS (636) 3762/3

ALSO FIRSTCLASS MEAT

the trio. His film "Charles mort ou vif" was well noticed at Cannes two years ago. His latest film, "Salamandre," has had tremendous success in Lausanne, and later in German speaking Switzerland. It filled a Lausanne cinema for seven weeks. For the first two weeks, its only audience were young, but then the "bourgeois" of the town, intregued, flocked in. The film was then screened in Paris, where it attracted more than 170,000 spectators.

There is no Swiss film industry in as much as there are no studios, no film-stars and no producer establishment. The Swiss films that come out usually star foreign actors. Tanner, Goretta and Soutter operate on shoe-string budgets. "Salamandre," for example cost only £20,000, about 1 per cent of an average commercial film. Despite the minimal means used, these films can't be compared to underground production. They comply with professional and commercial standard. Because he neither has the means nor the wish to work in 35-mm, the three cineasts operate with portable 16-mm cameras and synchronous sound recorders, helped by a couple of jack-of-all trades who handle the lighting. The 16-mm film is then blown up into a 35-mm film that can be used in commercial circuits. The effect of enlarging from 16 to 35-mm weakens the cellul-

oid's colour and lens rather mild, autumnal lines to outside shots which critics have wrongly interpreted as an expression of "Swiss spleen."

Despite encouragement grants awarded to Swiss producers and the success of several yearly film festivals in Switzerland, this type of cinema is condemned to remain the essence of Swiss film production in the foreseeable future. No spectacular films will ever come out of Switzerland, but those films that are produced are highly personnal and hardly subservient to commercial requirements.

ZURICH'S MUSICAL SEASON

Zurich's 1972-73 music season has just opened. With three chamber ensembles and one symphony orchestra at their disposal, the people of Zurich enjoy an exceptionally rich musical life for their relatively small population. The three chamber orchestras are The Zurich Chamber Orchestra conducted by Edmond de Stoutz, The "Camerata", conducted by Rätö Schupp, and the "Collegium Musicum" under Paul Sacher. These three ensembles have recently published their programmes. The Zurich Chamber Orchestra will give no less than twenty concerts with reputed artists like Francescatti, Peter

Pears, Askenazi, Kempff, Maurice André, Menuhin performing in modern and classical works. The "Camerata" and the "Collegium Musicum" will devote much of their programmes to modern or living composers. For example, the "Camerata" will perform the premiere of "Eve's meditation on Love" by Fdanz Tischauser, and a new oboe concerto by Robert Wittinger.

The musical centre of Zurich is of course the Tonhalle. The Tonhalle Orchestra and a number of prestigious foreign formations will give 24 concerts, five of them on Sunday afternoons, not counting eleven special concerts for youth and those given during the June Music Festival. The Tonhalle also has in store other events such as the "Hausabende", "Matinees de musique", and "Musica Viva", a new cheap season-ticket concert. In Spring, the Tonhalle will produce its "Cycle of Spring" series of five concerts devoted to a particular theme. This time it will be the violin concerto. Those of Katchaturian, Alban, Berg, Hans Werner Henze, Stravinski and Bartok are at present in the programme.

As one can see, the works of modern composers will be presented to the eminently conservative audience of the Tonhalle. But most of the moderns (Honegger, Hindemitz, Stravinski and Chostakovitch) are "Proven values".

The International Bank for International People.

Lloyds & Bolsa International Bank is strongly established in Western Europe and the Western Hemisphere.

LBI has a wide direct representation in the EEC and Switzerland, and is also the only British bank with a branch network covering virtually the whole of Latin America.

LBI plays an important role in the Eurocurrency market and has arranged finance for many major projects world wide.

The LBI Group, through its branches, associates and representatives in New York, Nassau, Paris, Frankfurt, Brussels, Amsterdam and Zurich, has a direct access to principal sources of foreign currencies in all the world's

great financial centres.

To these established features should be added LBI's experience and reputation gained in Eastern Europe, Japan, the Middle East and Australasia, and the Bank's valuable links with Lloyds Bank Limited and the Mellon Bank of Pittsburgh.

The Bank's multi-currency capability, its skill in tailoring the use of funds to meet specific requirements, its spread of branches and representatives throughout the world, all combine to make LBI of essential interest to any business operating across national frontiers.

LBI is represented in Switzerland by Lloyds Bank Europe with branches in Zurich, Geneva and Lugano. Contact the specialists:

ZURICH, 18 Borsenstrasse
Telephone 25-87-65

GENEVA, 1 Place Bel Air
Telephone 25-03-20

LUGANO, 9 Corso Pestalozzi
Telephone 3-90-91

 **LLOYDS & BOLSA**
International Bank Limited
40/66 Queen Victoria St. London EC4. Tel: 01-248 9822

SWISS BUSINESSMEN SURVEY PRESENT TRENDS

The Swiss Association for Commerce and Industry, better known by the name of its Central Committee, the "Vorort", met for its General Assembly at Beaulieu Palace in Lausanne, where the 53rd Comptoir Suisse had just opened its doors.

Mr. Ernst Brugger, Head of the Department of Economy was invited to speak, as was Mr. Fred Luchsinger, Editor in Chief of the "Neue Zürcher Zeitung". The latter developed the subject of "public opinion", while Mr. Brugger centred his exposé on the evils of inflation, which he said were responsible for poisoning industrial relations, causing excessive economic concentration and increasing income inequalities.

But the main address was delivered by Mr. Etienne Juno, President of the Vorort.

Speaking on behalf of this important caucus of Swiss industrialists, he greeted the recent signing of a free-trade agreement with the European Community. He said that the willingness of its members to recognise the particular political consequences of Switzerland's neutrality should be fully appreciated. We should not forget, he added, that internationalism has left the same mark on the coming generations as patriotism had done on their predecessors. Accordingly, independence didn't have the same meaning as before and could not be conceived outside without international co-operation.

Mr. Junod said that a country's standing and popularity in the world today was the result of the sacrifices it was ready to make in helping to solve the problems of the international community. Mr. Junod called on Switzerland to help reduce the differences between rich and poor countries. He said that aid to the third world should be respectful of economic laws and should preferably be considered as "co-operation".

Ordinary investments and not only free public aid should help developing countries to improve their standard of living. Distinction should be made between "generosity" and "co-operation". It was the latter which was economically realistic. Mr. Junod also said that the goal of improving an under-developed country's gross national product required parameters which usually could only be applied to rich nations. Economic thinking should take account of the differences between various levels of developments, in particular, of the fact that some countries do not even have a market to speak of.

Referring to the recent MIT study of various world expansion models, he said that its conclusions were too pessimistic and that only a continued

and harmonious growth would allow us to solve the main problem confronting mankind: Pollution.

Another leading economic body, the Swiss Association of Bankers, has supported the idea of a constitutional article giving the Confederation extended means of intervention in the economy.

In its 60th Annual Report, the Association welcomes a constitutional basis on the far-reaching decisions, the Federal Council might be called to take but would like a detailed list of exceptions guaranteeing the principle of free trade and industry. The Report also calls for more financial restraint from the Confederation, which it considers as partly responsible for the current rate of inflation. While supporting measures to encourage housing and private property, the Report regrets that "these measures and the suggested means of paying for them, should rely on the assumption of a persistence of inflation".

On the recent package of monetary measures taken to hedge against an inflow of speculative funds, the Report says that they have led to a shortage of liquidities on the Swiss market. The situation will however not be definitely and satisfactorily remedied before an overhaul of the international monetary system. The Swiss bankers say that Switzerland's membership to the International Monetary Fund should urgently be discussed. They accept that Special Drawing Rights will eventually become a universal means of payment, but felt that it was still premature to make a decision on this score.

Finally, the Association welcomes legal co-operation with America in the full respect of each country's legal systems and whatever the agreements concerning possible exceptions. The Report says that the struggle against international delinquency was not limited by international boundaries. It referred to a recent Federal Court decision calling on a Swiss banker to supply information on fiscal fraud to the American authorities. The court had invoked the double taxation convention. The Report said that future Swiss-American conventions should be more restrictive.

Six hundred bankers met at Interlaken for the 59th General Assembly of the Association. Its President, Mr. Alfred E. Sarrasin, expressed approval of a draft constitutional article giving the Confederation more competence in controlling the economy. He said that the package of measures decided earlier this year to prevent a stampede for the Swiss Franc should be maintained for only as long as necessary. He said that Swiss bankers were concerned about the present role of Special Drawing Rights and the increasing tendency to use them as international reserve currency in replacement of gold and dollars.

He clearly said that it was too early for Switzerland to join the International Monetary Fund.

In another address, Mr. Edwin Stopper, President of the Swiss National Bank, devoted an exposé on inflation. He said that the situation in Switzerland was getting intolerable, with inflation rates in second position in the industrial nations league. He strongly criticised the practise of "blindly" adapting salaries and wages to a moving prices index, and claimed that the Swiss price index, as conceived at present, was not intended to be automatically mirrored by wage rises.

COMPANIES

Swissair opens multi-purpose building in Buenos Aires

Swissair has opened its new Argentinian regional and national offices on central Santa Street. The 14 storey building was officially inaugurated in the presence of numerous business and diplomatic personalities on 12th September. Swissair occupies the ground floor reservations and the three top stories. The other floors are rented to businesses and embassies. The Swiss Embassy rents two floors, the Australian Embassy another three, while the Finnish Embassy and the French Consulate each rent another floor. The Union Bank of Switzerland, the firms Hoffman-La-Roche and Juan Kaslin also rent a floor each.

Swissair is running the restaurant attached to the building.

Philips closes its factory at La Chaux-de-Fonds

The giant Dutch electrical company Philips closes its La Chaux-de-Fonds factory on 31st January, 1973. About 40 people will be made redundant. The plant was founded in 1933, during depression years which particularly affected the watch industry.

At one time it had employed some 300 workers. Of late, it has centred its activities on the assembly of television sets for the Swiss market. The international management decided that operations on such a modest scale weren't profitable and decided to close down the works. This comes at a bad time for La Chaux-de-Fonds, which has suffered from concentrations in the watch industry and the shift of watch assembly lines to other towns.

Authier stops production

Olin Authier, a well-known Swiss ski manufacturer, will close down on

31st January of next year. The family firm Authier was taken over in 1969 by the American Olin Corporation. The new firm had planned to market high-quality and medium to low priced skis. These plans proved unpractical when the majority of the firm's turnover was accounted for by the lower-priced range, thus leaving insufficient profit margins. Some 120 workers will be made redundant.

Switzerland by Italian Television. The Swiss authorities complained of the film's "tendencious character".

The young members of the Swiss Radical Democratic (*Freisinnig*) Party rejected the idea of worker participation in management. Meeting for their Annual Congress in Solothurn, they passed a resolution stating that the maintenance of a "hierarchical structure" in which the responsibilities of every one were clearly defined was the only way to ensure a prosperous economy.

The Great Council of Valais deplored at the end of its last session new federal regulations prohibiting the sale of property to foreigners. They claimed that these measures were unrealistic and did not take into account the particular situation of the Valais peasant.

A strange man living at Coeuve, near Porrentruy, known as the "*Solitaire*", who kept up correspondance with Pope John XXIII, several bishops, the Federal Council, the Federal Assembly and many Ambassadors, set fire to his house and mysteriously dissapeared, causing turmoil in the area.

The West-Switzerland Electricity Board has received authorisation to erect an 800-Megawatt Nuclear Power Station at Verbois, near Geneva. Cost of the project is estimated at 1.2 billion

francs. Conservationist interests will need placating before construction gets under way.

Moving resolutely against the present trend for merging communes, the Commune of Schmitten (Fribourg) celebrated during three days of festivities the 50 Anniversary of its separation from the neighbouring commune of Dudingén.

Professor Hans Deutsch, an Austro-Israeli lawyer and Honorary Citizen of Belmont, near Lausanne, went on trial in Germany on charges of having fraudulently obtained, as the lawyer of despoiled Jewish families, 17.5 million francs of war-loss compensation for Baron Ferenc Havatny, whose art collection in Budapest had been stolen. The Germans alleged that the works had been stolen not by the Nazis, but by the Russians.

Switzerland was last in Group A at the Skopje Chess Olympics.

A new watchmaking and fine arts museum has been opened in Geneva in a villa on Malagnou Road.

The Great Council of Neuchatel ended its October Session by voting in favour of two motions concerning foreign residents. One resolution calls on cantonal authorities to seek the means of integrating aliens in the life of the host country through increased

LATER EVENTS

Having been approached by the British Government, the Federal Council has decided to offer refuge to 200 Ugandan Asians. In a communique, the Department of Justice and Police explained that the move was in keeping with traditional Swiss humanitarian principles. The operation will cost an estimated 1,300,000 francs.

The Political Department and the Swiss Embassy in Rome have protested to the Italian Government for the viewing of a film on Italian workers in



Swiss Life

INSURANCE AND PENSION COMPANY
(Incorporated with limited liability in Zurich Switzerland)

Mutual Company—Established 1857

**ASSETS EXCEED
£600 MILLIONS**

24 Cheapside, London E.C.2.
Telephone: 01-236 3841

Head Office: SCHWEIZERISCHE LEBENSVERSICHERUNGS-UND RENTENANSTALT, ZURICH.

RENTENANSTALT

specialises in Pension Plans for
International Companies with the

MASTER COVER CONTRACT

and offers in Great Britain all types
of life assurance and annuities.

30 Exchange Street East, Liverpool L2 3QB
Telephone: 051-236 6712