

Zeitschrift: Mitteilungen über Textilindustrie : schweizerische Fachschrift für die gesamte Textilindustrie

Herausgeber: Verein Ehemaliger Textilfachschüler Zürich und Angehöriger der Textilindustrie

Band: 60 (1953)

Heft: 9

Rubrik: Ausstellungs- und Messeberichte

Nutzungsbedingungen

Die ETH-Bibliothek ist die Anbieterin der digitalisierten Zeitschriften. Sie besitzt keine Urheberrechte an den Zeitschriften und ist nicht verantwortlich für deren Inhalte. Die Rechte liegen in der Regel bei den Herausgebern beziehungsweise den externen Rechteinhabern. [Siehe Rechtliche Hinweise.](#)

Conditions d'utilisation

L'ETH Library est le fournisseur des revues numérisées. Elle ne détient aucun droit d'auteur sur les revues et n'est pas responsable de leur contenu. En règle générale, les droits sont détenus par les éditeurs ou les détenteurs de droits externes. [Voir Informations légales.](#)

Terms of use

The ETH Library is the provider of the digitised journals. It does not own any copyrights to the journals and is not responsible for their content. The rights usually lie with the publishers or the external rights holders. [See Legal notice.](#)

Download PDF: 01.04.2025

ETH-Bibliothek Zürich, E-Periodica, <https://www.e-periodica.ch>

aber so haben, denn was einige Modeschöpfer jeweils für das Frühjahr und den Herbst als «modisch» bezeichnen, das gilt jeweils für ein halbes Jahr für die Textilindustrie in allen Erdteilen. Neben neuen Gewebetypen und neuen Mustern werden stets auch neue Farben geschaffen. Wir alle, die wir von den Launen der Mode abhängig sind, wissen über die Schwierigkeiten dieser Neuschöpfungen ein Liedlein zu singen. Wenn schon die Schaffung neuer Farben für Unistoffe nicht so einfach ist, wie der Laie es oft annimmt, so ist die Herstellung neuer Melangen für die Wollindustrie ein besonderes Kapitel und stets das Sorgenkind der Fabrikanten.

Diese Sorgen wird der Melangen-Atlas künftig ausschalten. In 7 prächtig gestalteten Bänden hat der Schöpfer dieses Atlases, der selbst in der Wollindustrie tätig ist, in jahrelanger Arbeit eine Sammlung von 3200 glatten Melangen und Noppen-Melangen ausgemustert und die jeweilige prozentuale Zusammensetzung der Grundfarben in einem Anhang beigelegt. Der Atlas wird nicht nur der gesamten Wollindustrie, sondern auch dem Tuchhändler ganz hervorragende Dienste leisten. Es wird künftig möglich sein, jede der 3200 Melangen jederzeit in demselben Farbton wieder herstellen zu können. Der Tuchhändler braucht seinem Stofflieferanten nur die Nummer der gewünschten Melange anzugeben und er wird genau die gleiche Nuance wieder erhalten und seine Kunden nach Wunsch bedienen können.

Die Bände I—V enthalten 528 Grundmelangen in allen denkbaren Mischungen. Sie sind nach Farbtönen und Helligkeiten derart geordnet, daß alle braunen, grünen, blauen und grauen Farbtöne je in einem Band zusammen-

gefaßt sind. Band VI enthält ebensoviele Effektmelangen in 2—6farbigen Noppenkombinationen aller Arten und solche mit Stichelhaaren von den hellsten bis zu den dunkelsten Farben. Band VII schließlich enthält die 144 Grundfarben und gibt in sehr übersichtlicher Anordnung Aufschluß über die genauen Mischungsprozentsätze aller 3200 Melangen. Ein geplanter VIII. Band soll alle verwendeten Grundfarben mit ihren Rezepten enthalten und den Käufern des Melangen-Atlas nach Erscheinen kostenlos nachgeliefert werden.

Der Melangen-Atlas ist in seiner prächtigen Ausführung mit den Wollmustern ein Standard-Nachschlagewerk und ein Handbuch, das der gesamten Wollindustrie und dem Wolltuchhandel wertvolle Dienste leisten wird. Der Preis darf als bescheiden bezeichnet werden. Das Werk von Ing. Leyerer, dessen textlicher Teil in nicht weniger als sieben Sprachen gehalten ist, hat in der Wollindustrie allgemeine Anerkennung und in kurzer Zeit schon weite Verbreitung gefunden. -t-d.

Kontinuierliches Klotz-Dampf-Färbeverfahren. — Von E. I. Du Pont ist ein solches Verfahren ausgearbeitet worden, das sich in den USA bereits sehr bewährt. Mit diesem Verfahren kann nicht nur mit Küpenfarbstoffen allein gefärbt werden, sondern auch mit Schwefelfarbstoffen und anderen Farbstoffgruppen. Ebenso gut sind auch die Ergebnisse beim Färben von Seide, Mischgeweben aus Baumwolle und Seide, Baumwolle und Wolle, Seide und Wolle, sowie Baumwolle mit Azetat, Seide mit Azetat, Zellwolle, Zellwolle und Baumwolle mit Wolle/Zellwolle. ie

Ausstellungs- und Messeberichte

Textile Machinery Exhibition Manchester 1953

ENGLAND, the home country of the spinning machine as well as of the mechanical weavingloom is, despite of the world-wide importance of its own large industry of textile machines, a very respectable buyer of Swiss textile machines. During many years she was in fact holding the first rank amongst the European customers of the Swiss textile machinery industry. In 1952 the value of textile machinery exported from Switzerland to England amounted to Fr. 14,640,000; the various customs positions participate towards this figure as follows:

a) spinning and throwing machines	Frs. 1,776,000.—
b) weaving looms	» 4,103,000.—
c) other weaving machinery	» 4,623,000.—
d) knitting and interlock machinery	» 4,138,000.—

The export-figure to England of the first half-year 1953 comes up to Fr. 5,265,000.—; same is consequently considerably below of the figure referring to the period January-June 1952 but, may nevertheless be considered by the Swiss textile machinery industry as a recognition of their efficiency by their British friends.

It is readily comprehensible, that our textile machinery manufacturers make every effort to maintain their position on the english markets. For this reason they will show their latest constructions on the **TEXTILE MACHINERY EXHIBITION** at **MANCHESTER** from the 14th — 24th of October 1953.

Hereafter we give, on behalf of our esteemed readers in England and Scotland, a brief summary of what the Swiss textile machinery industry exhibit in Manchester.—Doubt-

lessly they will be pleased to meet their old business friends there and... to entrust them with their valuable orders.

Joh. Jacob Rieter & Co., Limited, Winterthur.

On the "Cutdrafil" ring spinning frame tows of rayon, acetate and certain full synthetic fibres are cut to the desired staple length, drafted as required and spun into a wide range of counts, all in one operation. The special cutting and drafting arrangement, which replaces the "cracking" method hitherto known, consists of a pair of front and rear gripping rolls and intermediately-disposed cutting rolls which sever the tow. In other respects the machine resembles the modern Rieter ring spinning frame with movable spindle rails. A centrally-located adjusting device allows variations of the angle at which the tow is led into the cutting plane of the cutters, making possible the adaptation of the drafting arrangement to varying characteristics of the raw material, preparation, etc. and excluding practically any undesirable periodic changes in the yarn structure.

By setting the adjusting device and cutters the staple diagram and shrinkage can be varied.

The Cutdrafil machine works with a draft of 4—60 on staples ranging from 2"—6", whereby continuous filaments of 1000—6000 deniers are spun into cotton counts 20's—120's. Creel bobbins with a diameter up to 9" and weight up to 11 lbs. can be used. The spindle speed is adjustable between 5000—8000 rpm., and the twist range between 160—2530 t/m. The front roller delivery speed is 10—15 m/min. giving a production similar to that of an ordinary ring frame.

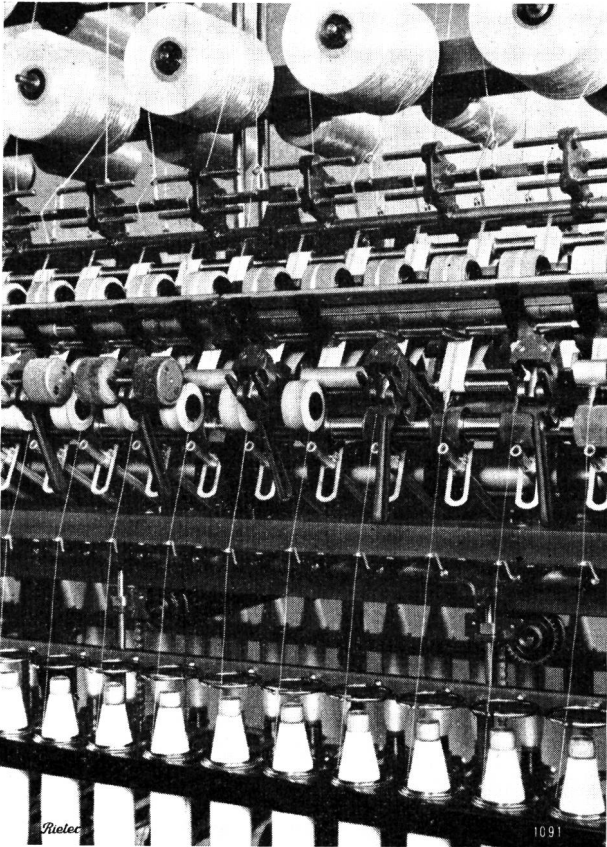

Close-up view of the new Rieter «Cutdrafil» machine which cuts, drafts and spins direct from filament tow.

The standard type Cutdrafil frame has 240 spindles, $3\frac{1}{2}$ " gauge and 10" lift, ring diameter $2\frac{3}{4}$ ". A motor of 7 kw. is used for the drive of the machine. The cutter shafts are driven by two auxiliary motors of 0.2 kw. each. For the thread suction device a motor of 0.63 kw. is provided.

Schärer Textile Machine Works Erlenbach/Zürich.

Modell BNSATV: The Fully Automatic Pirn Winder model BNSATV is a development of the well-known Schärer type "NON STOP" pirn winder for cotton, fibro, wool, worsteds or linen. The machine is provided with an automatic feeding device for the empty pirns, a dust removing device and an automatic stacking device for the wound pirns. The full pirns are collected, all lying in the same direction in a pirn box at the left hand end of the machine, thus avoiding any further handling or sorting before being carried to the loom.

Modell BNSAEV: The Fully Automatic Pirn Winder model BNSAEV is similar to the BNSATV, however, with the exception that the full pirns are collected in individual boxes at the foot of each winding unit. The machine is to be recommended for firms with a widely diversified production.

Modell HKBNSATV: This, the Schärer High Speed Fully Automatic Pirn Winder is a new feature, and has been evolved to meet the steady demand for high speed winding. The same principles of winding mechanism are used but have been modified to obtain high speeds. This machine is capable of working at a speed of 8000 revolutions per minute.

Modell BNSV: The Automatic Pirn Winder BNSV is an improvement on the standard machine in that it is equipped with the automatic dust and fly remover, and the empty pirns are carried in a container on a small travelling carriage which can be moved along the frame quite easily by the operator. Another advantage is that this ma-

chine can be converted into a fully automatic machine.

Modell SNSE: The Automatic Pirn Winder SNSE is the standard silk and rayon winder, built on a low frame, with special tension devices to wind also synthetic fibres, and a carriage to keep the empty pirns which can be moved along the frame at will.

Modell PKK: The Precision Cone Winder PKK is suitable for silk and rayon yarns, its chief feature being the patented differential friction drive ensuring constant yarn speed.

Schweiter Limited, Horgen (Zurich).

The Winding Machines of Schweiter Limited, Horgen, Zurich, Switzerland, have been famed in the English Textile Industry for over a large number of years and as such they welcome this further opportunity to renew acquaintances with their many English customers and, indeed, future customers.

At the forthcoming Manchester Exhibition the Schweiter Stand No. D. 27 will be particularly interesting because no less than 8 different types of machines, many of them new, will be shown. Moreover there will be some new devices and attachments. The machines will demonstrate not only the range but also the versatility of Messrs. Schweiter Ltd.

This year the Super Automatic Pirn Winder type MSL with the Automatic Pirn Feed Device, which has achieved considerable popularity will be shown, however, for the first time it will be fitted with a highly efficient vacuum cleaning system. In addition each apparatus will be fitted with their New «Hamster» Automatic Pirn Box Filling Device.

The Automatic Pirn Winder type MS fitted with the new Multi-cell Battery will, of course, be shown. This machine will be for winding cotton, wool, linen, etc.

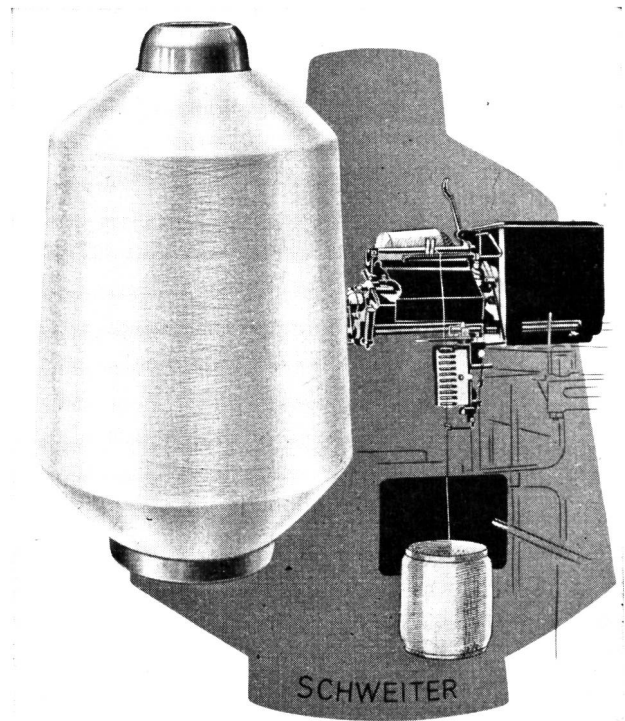

Precision-Crosswinder type KEK-PN «Monofil-Coner» for the handling of nylon and similar fully synthetic yarns.

A new and interesting feature concerning their Automatic Pirn Winder will be the MSK-N machine for winding of Nylon, Terylene, Perlon, etc. This machine has been specially designed for use with the newer synthetic yarns. The new «Schweiter» Nylon Tension, shown for

the first time, should prove to be of particular interest. Each spindle of this machine will be fitted with the *Automatic Pirn Tray Loading Device*.

The *Automatic Hollow Cop Winder type MT* for use with wool, linen and jute will be shown winding both wool and jute. This machine will be fitted with Messrs. Schweiter's latest *Bobbin Magazine Supply System*. This supply system is completely new and avoids the dual process of first winding the yarn from bobbin to cone. Again for the first time this machine will be fitted with a conveyor belt which carries the wound cops to one end of the machine and packs them automatically and neatly into a bag.

Among the many cone winders built by Messrs. Schweiter Limited, the «*Monofil-Coner*» will prove to be a very interesting exhibit, particularly in this «Nylon age». This machine has already achieved a very large amount of success on the Continent.

For the first time in the world this Exhibition gives Messrs. Schweiter Limited the opportunity of showing their latest *High Efficiency Cone Winder type KS*, winding cones of 6½ lbs weight onto paper tubes of 9'15" taper at a yarn speed of 1100 yards per minute. This machine will also be fitted with a *High Efficiency Vacuum Cleaning System* and once more this exhibit should be a «must» for all who visit the Exhibition.

Messrs. Schweiter's agents in this country are Messrs. Livesey & Aspinall Limited, 16 Cumberland Street, Deansgate, Manchester. 3. who will be only too pleased to assist anyone who wishes to visit this Exhibition.

Sam. Vollenweider Ltd., Horgen, Switzerland, present a machine which is liable to cut costs very considerably of any Cloth Room or Cloth Picking Department.

The *Selvedge Trimming Machine WAM* which is no unknown machine on the English market, cuts off the loop threads at the selvedge of weft check cloths, and also the float threads of automatic loom cloth, which it does with extreme neatness, accuracy and of course, at much higher speed than the manual process.

It is claimed that the average production lies at about 7000 yds per 8 hour day but there are English Mills which reach the immense figure of between 100,000 and 120,000 yds in a 80 hour week, although on automatic loom cloth only. It is obvious that under the circumstances the WAM machine can replace a good number of labour and reduces costs considerably.

The machine features some alterations: it is now fitted with a hydraulic variable speed gear permitting speed of cloth of up to 63 yds per minute, and with a new, stronger dust exhaustor. It can be supplied in three different types: with a rolling device only at the delivery end of the machine, or with a folding device only, or with both a rolling and folding device.

A chain stitch sewing machine of the «railway type» is also exhibited, and is used for stitching cloth piece to piece by an absolutely straight seam. It is particularly suitable for machines which are continually fed with cloth. Driven by a small electric motor it stops automatically at the end of the cloth when a seam is finished and reduces stitching time to a minimum.

Messrs. **Zellweger Ltd, Uster** (Switzerland) will exhibit the following products at this years' Textile Machinery Exhibition in Manchester:

- «Little Uster» Warp Tying Machine
- «Uster» Dropper Pinning Machine
- «Zellweger» Denting Machine
- «Uster» Evenness Tester
- «Uster» Varimeter
- «Uster» Varisignal
- «Uster» Yarn Strength Tester

«Uster» Staple Diagram Apparatus

«Uster» Hand Knotter

«Uster» Thread Tension Gauge

Besides these they will also exhibit their newest construction the

«USTER» AUTOMATIC DRAWING-IN MACHINE

This machine, a product of a decade of study and development, was shown at the Basle Fair, this year, for the first time, after a prototype was tried out for seven years in one of the large Swiss fine coloured cotton weaving mills as to its efficiency and its versatility. The experiences gained during this trial period confirm the superiority of the system chosen by Messrs. Zellweger Limited for the drawing-in of normal round steel, flat steel and Duplex healds. Interested firms for this machine therefore do not have to consider the purchase of any new additional accessories (healds, shafts). The «Uster» automatic Drawing-in Machine is designed in accordance with the latest knowledge of the developments of modern machine design. It is driven by a Ward-Leonard unit. It has a magnetic coupling and central lubricating system and is controlled by a system of feelers so that a reliable and perfect operation is guaranteed. All the driving organs are well cased with easy access if necessary. It is controlled by an ordinary punched dobby card, as used on dobbies, which guarantees a safe and accurate drawing-in of each draft up to 28 shafts. It can draw-in any kind of warp with an end and end lease.

Grob & Company Ltd. Horgen:

The famous GROB products will be on show at the Manchester Exhibition, not only on their own stand D 43 but also in operation on various looms. The equipment on display will include the well known All-Purpose Flat Steel Healds together with the Light Metal Slider Weaving Frame, and examples of various type of healds for leno weaving. The latter product is one of the specialities of this firm.

The latest development to come from their workshops is a new type electric Warp Stop Motion KFW 1000 for use with Silk and Rayon. This apparatus was on show at the Basel Fair for the first time, and created a good deal of interest among manufacturers of silk and rayon goods. Electric Warp Stop Motions KFW 785 and KFW 870 for use with wool and cotton respectively will also be on display.

Another discovery attributable to Grob & Company is the new type finish for Drop Wires called «GROBAT». From the many exhaustive tests made it has already proved to be the best protection against rust which has been put on the market up to the present. Millions of drop wires, GROBAT finish, have found their way into mills all over the world during the last few months.

Added to the British representatives Messrs. M. H. Spencer Ltd., Coventry, and Messrs. S. Smith (Healds) Ltd., Bradford, members of the technical staff from Horgen will also be in attendance.

Brügger & Co. Ltd. Horgen (Switzerland), who, as the originators of the spindleless method of winding, will show their latest model «GIROMAT» automatic pirn-winding machine incorporating the newest principle of low tension high speed winding for synthetic and other yarns.

Realising that the rapid development of the synthetic fibres such as Terylene, Orlon, Perlon and, of course, Nylon was bringing winding problems quite distinct from those which had been faced during the past 50 years, Brügger has developed this new principle of high speed winding of these yarns at extremely low and regular tensions.

This has been achieved by the introduction of a new design of multiple layerlocking cam and a completely

revised compensating tension device "SYNCHROMAT" (patent applied for), in which the yarn passes first over the compensator arm and then through the tension discs with the result that the variations in tension caused in removing the yarn from the supply package are compensated *before* the yarn reaches the tension discs and so a constant tension to the spindle point is maintained at all times.

The "SYNCHROMAT" tension-device is a compact apparatus which can be fitted on to all types of cone winding and pirnwinding machines. It is of course ideal for all classes of synthetic yarns, where variations in tension can lead to serious cloth faults.

Rüti Machinery Works Ltd., Rüti/ZH.

The *Rüti High Speed Pirn Change Cotton Loom BANLXK* for higher outputs in the single-shuttle range was shown for the first time in April this year at Basle. This new loom has overcome the difficulties formerly faced in running automatic looms at high speed, by the use of light shuttles of a special design which eliminates the normal heavy shuttle jaws, and by the use of a special loosereed mechanism. In spite of the higher loom speed, there is no aggravation of yarn breakages.

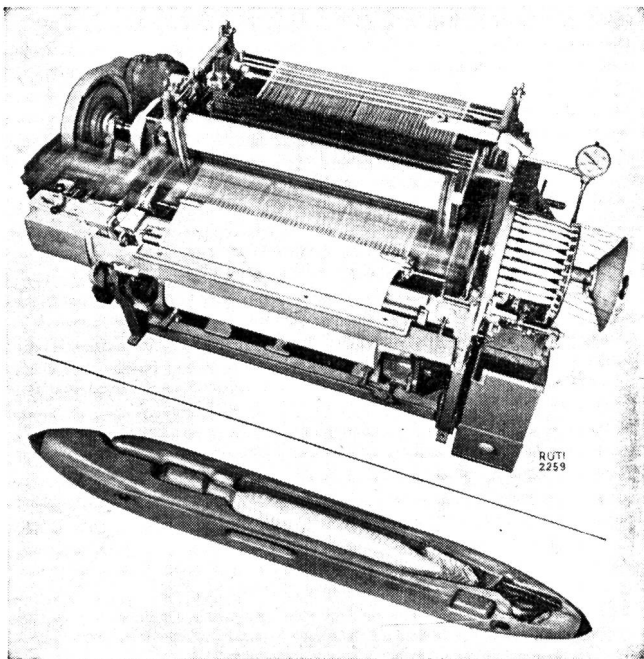

Rüti High Speed Cotton Loom BANLXK and the new shuttle

The *Rüti Automatic Pirn Change Silk Loom SINZAW/2* is also a new feature. Success in weaving rayon and silk on automatic pirn changers is dependent on faultless operation of the entire automatic movement, the use of the lightest possible shuttles, correct thread tensioning, with the assurance that the thread is not drawn into the cloth after the pirn change. These requirements have been fully accommodated in this new Silk Loom.

The *Rüti High Speed Sectional Warping Machine SZU* is the result of many years of experience and meets the requirements of up-to-date weaving methods. The machine is intended for making warp lengths of 750, 1500 or 3000 yards, the required length being determined by the setting of a clock provided for this purpose. The totally closed drum, with a circumference of 4 metres is made entirely of metal, and is designed in such a way as not to cause any draughts of air liable to disturb the warp.

The new *Rüti Vacuum Creel GLSK* is being shown for the first time in this country, and has solved the difficulty of adapting the thread tensioning to the yarn count on delicate yarns. All vacuum controlled tensioning elements can be infinitely varied from a central point by turning a hand wheel.

Benninger Machinery Works Ltd. Uzwil.

The main feature of the stand of the Benninger Engineering Ltd. will be their latest model high speed section warper complete with creel and creel stop motion. — The Benninger warper is made in three different types. Type ZAS is used in silk and rayon mills, but is also applied successfully for cotton in particular for striped warps and folded yarn which need not be sized. Type ZAL with a shorter and consequently steeper cone is used for worsted and woollen yarns and type ZAT is fitted with special attachments which make the machine suitable for the warp knitting industry.

A number of optional attachments are available with the Benninger warper, including a cone height determinator, an ingenious device on the yardage counter which enables the necessary height for a particular warp to be read off on a scale and the cone adjusted accordingly.

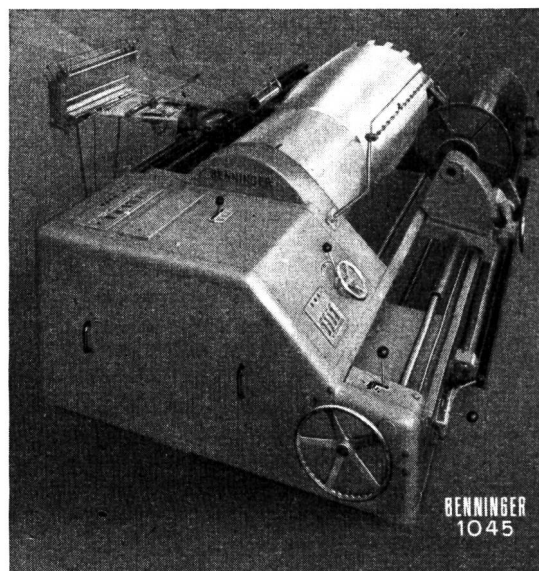

The Benninger high speed warper

Working in conjunction with the new warper will be Benninger's single-end creel which is of extremely sturdy construction and the tensioning arrangement of which is designed to give a wide variety of tensions by means both of weighted discs and by the change in angle of delivery of the yarn. — Applied to this creel is the new type Benninger creel stop motion which can of course be applied to any make of creel.

The *FIBE 4 Bowl Dyeing Padder* which Benninger will show at the exhibition however is of completely revolutionary design and will dye fabrics in one passage through the machine at speeds of as much as 35 metres per minute.

One of the chief causes of faults in nylon fabric has been the stoppage of the loom for re-shuttling and it is in this respect that the Benninger automatic loom has many advantages. The Benninger automatic 4 shuttle loom which will be shown at Belle Vue is unique in that it will change its shuttles automatically on as many as four colours of weft and will make this change without stopping the loom for even one pick.

Jakob Jaeggli & Cie., Winterthur/Switzerland.

The firm of Jakob Jaeggli & Cie, Winterthur, Switzerland, established in 1842, started in 1879 the construction of mechanical looms for silk. Since that time, the firm has developed these machines, always keeping pace with the progress of technique, and ultimately succeeded in building, as the first, electric looms for silk and rayon.

At the Textile Recorder Machinery Exhibition two of the latest models of JAEGLI looms will be shown and explained in operation on Stand No. B 14, Hall 2.

A novelty will be the electric semi-automatic 4-4 box Pick-at-Will loom, 46" reed space, fitted with the new VERDOL machine of the Société des Mécaniques Verdol, Lyons, and suitable for the manufacture of fancy goods, art fabrics, and tie material. Almost all control organs of this loom are electric, but the most outstanding features are the three push-button control for starting and stopping with lay in its forward or backward position, and the electric picking disengagement device, which is unique in its kind and ensures vibrationless running of the loom even at high speed. Owing to the ingenious design, handling of the machine requires very little effort. The various electric control devices simplify attendance and ensure a maximum effect with regard to the quality of fabrics and the economy. Electric looms have proved superior and epoch-making.

The second loom, also electrically controlled throughout, is a fully automatic 4-1 box bobbin changing loom, suitable for the manufacture of ladies' rayon dress material.

The firm is further specialised in the Hydrology and in this field makes warp beam jacks for the transport and location of warp beams into looms. Two types are shown, namely the normal one HW-3, and HW-13cs with 4 guide-wheels and bearing plate with lateral projection particularly suitable for Northrop looms with taffeta device and for Lancashire looms. A special type of lifting jack, HW-29, for dyeworks can also be seen. — The High-Light, however, are the JAEGLI hydraulic hank meringing plants, known all over the world. Three types are available: MM-3 for 54" hanks and an output of 88 lbs. per hour, MM-6 for 54" hanks and 168 lbs. production per hour per man, and MM-10 for 90" hanks.

Georg Fischer Ltd., Schaffhausen.

One of the most important of post war developments in the weaving of fabrics from synthetic yarns has been the increasing use which has been made of pirn changing looms so that these fabrics could be produced with all the economic and technical advantages of automatic weaving.

There have of course been many problems to be overcome in the use of continuous filament yarn as compared with spun yarns of cotton, etc. and on the stand of George Fischer Ltd. of Schaffhausen, Switzerland, will be seen the results of a very considerable amount of experiment in the conversion of existing non-automatic rayon looms to automatic weaving both with single and multicolour weft.

On a pre-war silk underpick loom will be shown the Fischer conversion mechanism which has made this loom into a fully automatic 2 × 1 box loom for two colours of weft. A similar mechanism, with only a slight modification, is also being used by Jacob Jaeggli & Co. on their new silk looms for weaving of up to 4 colours of weft and is being shown by them on their own stand at the exhibition.

In addition to the multi-colour pirn change conversions Messrs. Fischer will also be showing a Dobcross 4 × 4 box woollen loom converted to single pick weft mixing on

3 shuttles in rotation. This is an extremely important conversion for the woollen trade where large numbers of Dobcross and similar looms are used for straight forward 3-shuttle weft mixing. In the Fischer conversion the 4 box motion on one side of the loom is removed and is replaced with a specially designed two-compartment drop box and it is on this side that the change takes place, always when the empty shuttle is the top box during the cycle when the lower box is empty. In this way it is possible to obtain the maximum effect from weft mixing on 3 shuttles and at the same time all the economic advantages of automatic weaving.

Stäubli Brothers & Company Horgen/ZH point out:

1 *Single Cylinder Cam Dobby* with Paper Pattern, Type LEdf, with Hand Pickfinder and Heald Staggering Motion, mounted on a Livesey loom, with 2 Spring Undermotions built in.

1 *Cardcutting and Copying Machine* Type N, with pick counter.

1 *Shuttle Truing Machine* Type WEM, with Pirn Rectifying.

Shaft Regulators.

It is clear that also Messrs. **Adolph Saurer Ltd., Arbon**, will be represented with a group of her well known looms. We give hereover some informations in our next issue.

Textilien und Mode an der Messe in Dornbirn. — Dornbirn, UCP. Am 31. Juli wurde die 5. Export- und Mustermesse in Dornbirn eröffnet. In der kurzen Zeit des Bestehens ist die Dornbirner Messe zu einem bedeutenden Begriff geworden, denn rund 1150 Firmen des In- und Auslandes meldeten sich zur Schau an, von denen aber nur 962 zugelassen werden konnten, weil der zur Verfügung stehende Platz nicht ausreichte.

Naturngemäß ist in Dornbirn die Textil- und Bekleidungsindustrie stark vertreten, denn im österreichischen Bundesland Vorarlberg arbeiten 203 Textilfabriken. 42 Prozent aller Baumwollwebstühle, 41 Prozent der Rundstrickmaschinen, 8 Prozent der Tuchwebstühle laufen im Vorarlberg. Rund 15 000 Arbeiter und Angestellte arbeiten in der vorarlbergischen Textilindustrie (bei einer Bevölkerungszahl von 200 000). Allein nach dem zweiten Weltkrieg wurden im Vorarlberg 25 neue Textilfabriken gegründet. Neben den Fabriken gibt es auch eine große Anzahl industrieller und gewerblicher Kleinbetriebe.

Nach dem zweiten Weltkrieg wurde vor allem die Vorarlberger Textilindustrie stark modernisiert und vorwiegend mit deutschen, englischen und österreichischen Maschinen ausgerüstet. Es werden hier alle gangbaren Arten von Geweben und Stoffen hergestellt und sämtliche verfügbaren Textilmaschinen laufen derzeit voll.

Um die reichhaltige Stoffkollektion den Besuchern augenfällig vorzudemonstrieren, ging eine wahrhafte Mammut-Modenschau über die Bretter. In der vielfältigen Stoffkollektion fielen die für Oesterreich neuen Stoffe Everglaze auf; dann aber auch die neuartige Mischung Wolle/Seide, die sich durch den guten Fall auszeichnet. Stark vertreten waren die synthetischen Gewebe, wie Orlon, Perlon und Nylon, Nylontaft und andere metalledurchwirkte Stoffe (golden, silbrig, kupfern und andere) beeinflussen die großen Abendkleider. Italien bringt ausgesprochen dunkle Farben für die Tageskleider. Die großblumigen Muster sind im wesentlichen passé. Gerautes Everglaze beeinflusst die Herbstmode und findet vorwiegend für Damen-Morgenröcke Verwendung.